

# Clean Water 2020



Columbia's Clear Vision For Clean Water

## **Final Consent Decree City of Columbia**

**May 21, 2014**

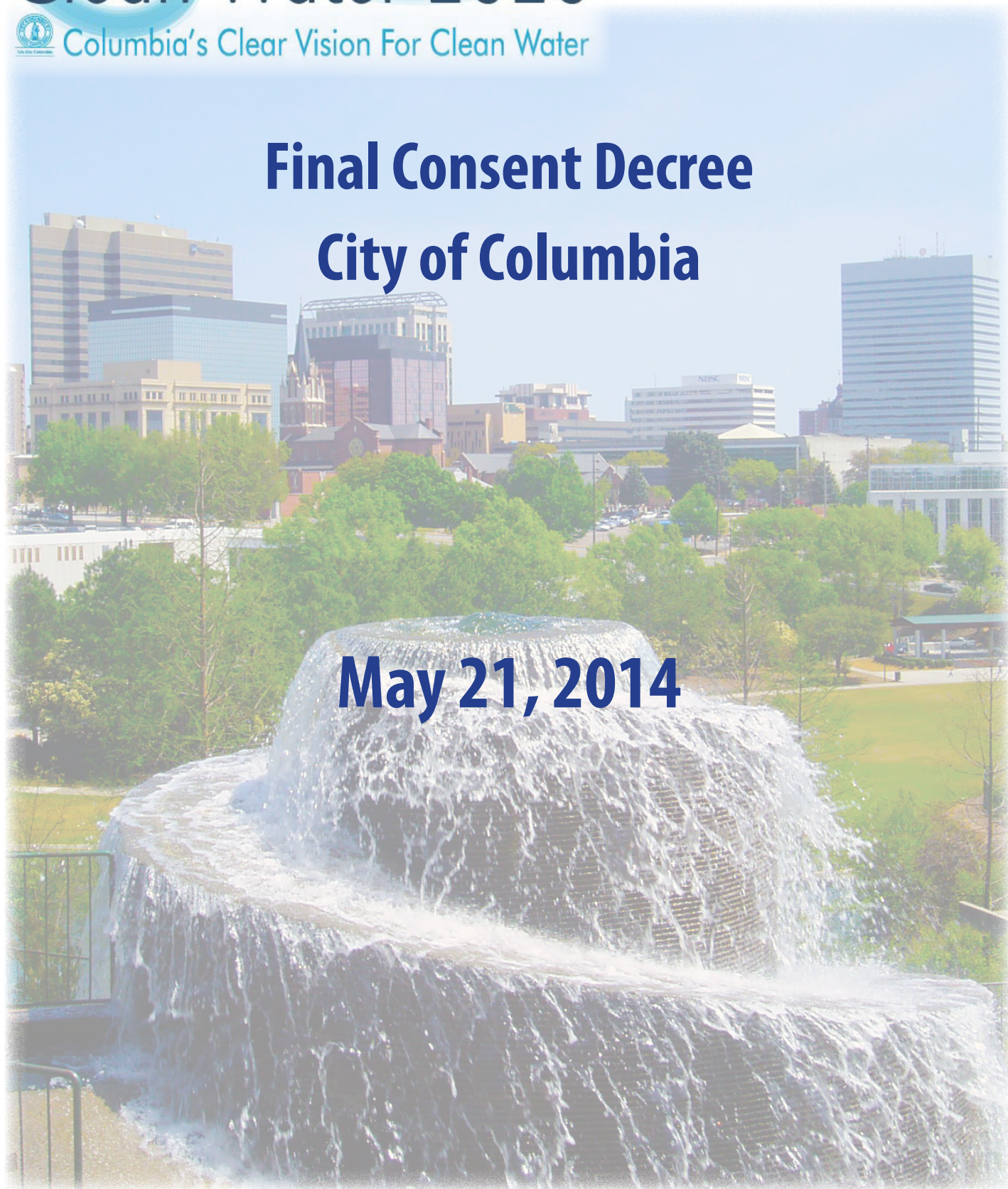

IN THE UNITED STATES DISTRICT COURT  
FOR THE DISTRICT OF SOUTH CAROLINA  
Columbia Division

|                                  |   |                                |
|----------------------------------|---|--------------------------------|
| THE UNITED STATES OF AMERICA     | ) | Civil Action No. 3:13-2429-TLW |
|                                  | ) |                                |
| and                              | ) |                                |
|                                  | ) |                                |
| STATE OF SOUTH CAROLINA by and   | ) |                                |
| through the DEPARTMENT OF HEALTH | ) |                                |
| AND ENVIRONMENTAL CONTROL,       | ) |                                |
|                                  | ) |                                |
| Plaintiffs,                      | ) |                                |
|                                  | ) |                                |
| v.                               | ) |                                |
|                                  | ) |                                |
| THE CITY OF COLUMBIA,            | ) | <u>CONSENT DECREE</u>          |
|                                  | ) |                                |
|                                  | ) |                                |
| Defendant.                       | ) |                                |

TABLE OF CONTENTS

I. JURISDICTION AND VENUE.....6

II. APPLICABILITY.....6

III. OBJECTIVES.....8

IV. DEFINITIONS .....8

V. COMPLIANCE REQUIREMENTS.....15

VI. REVIEW OF DELIVERABLES .....65

VII. CIVIL PENALTY .....69

VIII. SUPPLEMENTAL ENVIRONMENTAL PROJECT .....70

IX. REPORTING REQUIREMENTS.....74

X. STIPULATED PENALTIES .....77

XI. FORCE MAJEURE.....82

XII. DISPUTE RESOLUTION .....84

XIII. RIGHT OF ENTRY AND INFORMATION COLLECTION AND RETENTION.....87

XIV. EFFECT OF SETTLEMENT/RESERVATION OF RIGHTS.....89

XV. COSTS .....91

XVI. NOTICES.....91

XVII. EFFECTIVE DATE .....94

XVIII. RETENTION OF JURISDICTION.....94

XIX. MODIFICATION.....94

XX. TERMINATION.....95

XXI. PUBLIC PARTICIPATION.....96

XXII. SIGNATORIES/SERVICE.....96

XXIII. INTEGRATION.....97

XXIV. FINAL JUDGMENT.....97

XXV. APPENDICES.....97



WHEREAS, Plaintiff, the United States of America (“United States”), by the authority of the Attorney General of the United States and through its undersigned counsel, acting at the request and on behalf of the United States Environmental Protection Agency (“EPA”), has filed a Complaint contemporaneously with the lodging of this Consent Decree alleging that Defendant, the City of Columbia, South Carolina (“Columbia”), has violated and continues to violate Section 301 of the Clean Water Act (“CWA”), 33 U.S.C. § 1311, and the terms and conditions of its National Pollutant Discharge Elimination System (“NPDES”) permit issued under Section 402 of the CWA, 33 U.S.C. § 1342;

WHEREAS, Plaintiff, the South Carolina Department of Health and Environmental Control (“DHEC”), on behalf of the State of South Carolina (“State”), has joined in the Complaint and seeks injunctive relief and civil penalties for Columbia’s alleged violations of the South Carolina Pollution Control Act (“SCPCA”), S.C. Code Ann. §§ 48-1-10 *et seq.*, and the regulations promulgated pursuant thereto. Section 309(e) of the CWA, 33 U.S.C. § 1319(e), requires the state in which a municipality is located to be joined as a party whenever the municipality is a party to a civil action brought by the United States under Section 309 of the CWA;

WHEREAS, Columbia is a “municipality” pursuant to Section 502 of the CWA, 33 U.S.C. § 1362;

WHEREAS, DHEC has been authorized by EPA to administer the NPDES program pursuant to Section 402(b) of the CWA, 33 U.S.C. § 1342(b);

WHEREAS, Columbia’s Wastewater Collection and Transmission System (“WCTS”) transports wastewater to a publicly owned wastewater treatment plant (“WWTP”),

the Columbia Metro WWTP, which is operated by Columbia pursuant to NPDES Permit Number SC0020940. A map of the service area for the Sewer System is attached hereto as Appendix A;

WHEREAS, Columbia has reported to EPA and DHEC numerous Sanitary Sewer Overflows (“SSOs”) and other violations of the NPDES Permit in the past five years. The United States and the State contend that these reported events are violations of the CWA, SCPCA, and Columbia’s NPDES Permit;

WHEREAS, Columbia has voluntarily undertaken various capital improvement projects intended to improve its WCTS and WWTP as well as reduce the occurrence of SSOs, which, over the past five years, have resulted in significant expenditures of resources by Columbia;

WHEREAS, this Consent Decree requires Columbia to develop, submit, finalize, and implement existing and additional plans for the continued improvement of its WCTS and WWTP, with the goal of eliminating future SSOs and other violations of the NPDES Permit;

WHEREAS, the Parties to this Consent Decree have negotiated in good faith and have reached a settlement of the issues raised in the Complaint;

WHEREAS, Columbia does not admit any liability to the United States or the State arising out of the transactions or occurrences alleged in the Complaint;

WHEREAS, the Parties recognize, and the Court by entering this Consent Decree finds, that this Consent Decree has been negotiated by the Parties in good faith and will avoid litigation among the Parties and that this Consent Decree is fair, reasonable, and in the public interest;

NOW THEREFORE, with the consent of the Parties, it is hereby ORDERED, ADJUDGED and DECREED as follows:

## **I. JURISDICTION AND VENUE**

1. This Court has jurisdiction over the subject matter of this action, pursuant to 28 U.S.C. §§ 1331, 1345, and 1355, and Section 309(b) of the CWA, 33 U.S.C. § 1319(b), and over the Parties. This Court has supplemental jurisdiction over the state law claims asserted by the State pursuant to 28 U.S.C. § 1367. Venue is proper in the District of South Carolina pursuant to Section 309(b) of the CWA, 33 U.S.C. § 1319(b), and 28 U.S.C. §§ 1391(b) and 1395(a), because the violations alleged in the Complaint are alleged to have occurred in this judicial district, and pursuant to 28 U.S.C. § 1391. For purposes of this Decree, or any action to enforce this Decree, Columbia consents to the Court's jurisdiction over this Decree and any such action and over Columbia and consents to venue in this judicial district.

2. For purposes of this Consent Decree, Columbia agrees that the Complaint states claims upon which relief may be granted pursuant to Sections 301 and 402 of the CWA, 33 U.S.C. §§ 1311 and 1342, and 28 U.S.C. §§ 516 and 519 and SCPCA, S.C. Code Ann. §§ 48-1-10 *et seq.*

## **II. APPLICABILITY**

3. The obligations of this Consent Decree apply to and are binding upon the United States and the State, and upon Columbia and any successors, assigns, or other entities or persons otherwise bound by law.

4. No transfer of ownership or operation of any part of the Sewer System, whether in compliance with the procedures of this Paragraph or otherwise, shall relieve Columbia of its obligation to ensure that the terms of the Consent Decree are implemented, unless (1) the

transferee agrees in writing to be bound by and assume responsibility for compliance with applicable provisions of this Consent Decree and to submit to the jurisdiction of the Court for its enforcement by becoming a Party under the Consent Decree and (2) the United States, in consultation with DHEC, approves the substitution of the transferee and consents to relieve Columbia of the applicable obligations. The United States' decisions shall not be subject to judicial review. At least thirty (30) Days prior to such proposed transfer, Columbia shall provide a copy of this Consent Decree to the proposed transferee and shall simultaneously provide written notice of the prospective transfer, together with a copy of the proposed written agreement, to EPA Region IV, the United States Attorney for the District of South Carolina, the United States Department of Justice and DHEC, in accordance with Section XVI of this Decree (Notices). Any attempt to transfer ownership or operation of the Sewer System without complying with this Paragraph constitutes a violation of this Decree. This Paragraph will not apply to the transfer of a portion of the WCTS to Richland County pursuant to the Lower Richland Sewer Service Agreement attached hereto as Appendix B.

5. Columbia shall provide a copy of this Consent Decree to all officers, employees, and agents with responsibility for overseeing implementation of work required under this Consent Decree, as well as to any consultant or contractor retained to perform Work required under this Consent Decree. Columbia shall condition any such contract upon performance of the Work in conformity with the terms of this Consent Decree.

6. In any action to enforce this Consent Decree, Columbia shall not raise as a defense the failure by any of its officers, directors, employees, agents or contractors to take any actions necessary to comply with the provisions of this Consent Decree.



### **III. OBJECTIVES**

7. The objective of the plans, measures, reports, construction, maintenance, operational requirements, and other obligations in this Consent Decree or resulting from the activities required by this Consent Decree is to cause Columbia to achieve and maintain full compliance with the CWA, the SCPCA, and the NPDES Permit, including the goal of eliminating all future SSOs.

### **IV. DEFINITIONS**

8. Terms used in this Consent Decree that are defined in the CWA or in regulations promulgated pursuant to the CWA shall have the meanings assigned to them in the CWA, 33 U.S.C. §§ 1251 *et seq.*, and regulations promulgated under the CWA, unless otherwise provided in this Decree. Whenever the terms set forth below are used in this Consent Decree, the following definitions shall apply:

a. “Building Backup” shall mean a release of wastewater into a building or onto private property that is caused by blockages, flow conditions, or other malfunctions in the WCTS. A wastewater backup or release that is caused by blockages, flow conditions, or other malfunctions of a Private Lateral or other piping/conveyance system that is not owned or operationally controlled by Columbia is not a Building Backup.

b. “Bypass” shall have the meaning set forth at 40 C.F.R. § 122.41(m).

c. “Calendar Quarter” shall mean the three-month period ending on March 31, June 30, September 30, or December 31.

d. “Calendar Year” shall mean the 12-month period starting on January 1 and

ending on December 31.

e. “Certification” or “Certify” shall mean compliance with the certification requirements in Section VI (Review of Deliverables) of this Consent Decree.

f. “Columbia” shall mean the City of Columbia, South Carolina, including all of its departments, agencies, instrumentalities such as the Public Works Department, and any successor thereto.

g. “Complaint” shall mean the complaint filed by the United States and the State in this action.

h. “Consent Decree” or “Decree” shall mean this consent decree document and all appendices attached hereto (listed in Section XXV). In the event of a conflict between this document and any appendix, this document shall control.

i. “CWA” shall mean the Clean Water Act, as amended, 33 U.S.C. §§ 1251, *et seq.*

j. “Date of Entry” shall mean the date on which this Consent Decree is entered by the United States District Court for the District of South Carolina.

k. “Date of Lodging” shall mean the date this Consent Decree is lodged with the Clerk of the Court for the United States District Court for the District of South Carolina.

l. “Day” shall mean a calendar day unless expressly stated to be a business day. In computing any period of time under this Consent Decree, where the last day would fall

on a Saturday, Sunday, or federal holiday, the period shall run until the close of business of the next business day.

m. “Defendant” shall mean the City of Columbia, South Carolina and any successor thereto.

n. “Deliverable” shall mean any written document required to be prepared and/or submitted by or on behalf of Columbia pursuant to this Consent Decree.

o. “DHEC” shall mean the South Carolina Department of Health and Environmental Control and any successor departments or agencies of the State.

p. “Discharge Monitoring Report” or “DMR” shall mean the monitoring report which Columbia is required to submit to DHEC on a monthly basis pursuant to its NPDES Permit.

q. “DOJ” shall mean the United States Department of Justice.

r. “EPA” shall mean the United States Environmental Protection Agency and any of its successor departments or agencies.

s. “Effective Date” shall have the definition provided in Section XVII.

t. “Excessive Inflow / Infiltration” or “Excessive I/I” shall have the meaning provided in 40 C.F.R. § 133.103(d) and 40 C.F.R. § 35.2005(b)(16).

u. “Force Main” shall mean any pipe that receives and conveys, or whose purpose is to receive and convey, wastewater under pressure from the discharge side of a pump.

v. “Gravity Sewer Line” or “Gravity Sewer” shall mean any pipe that receives, contains and conveys, or whose purpose is to receive, convey, and contain, wastewater not normally under pressure, but unassisted under the influence of gravity.

w. “Infiltration” shall mean water other than wastewater that enters the WCTS (including sewer service connections and foundation drains) from the ground through such means as, but not limited to, defective pipes, pipe joints, connections, or manholes. Infiltration does not include and is distinguishable from Inflow.

x. “Inflow” shall mean water other than wastewater that enters the WCTS (including sewer service connections) from sources such as, but not limited to, roof leaders, cellar drains, yard drains, sump pumps, foundation drains, area drains, drains from springs and swampy areas, manhole covers, cross connections between storm sewers and sanitary sewers, catch basins, cooling towers, storm water, surface runoff, street wash waters, or drainage. Inflow does not include and is distinguished from Infiltration.

y. “I/I” shall mean the total quantity of water from Inflow, Infiltration, and rainfall induced Infiltration.

z. “Major Gravity Sewer Line” shall mean any of the following:

(i). a Gravity Sewer Line that is fifteen (15) inches in diameter or larger;

(ii). a Gravity Sewer Line that conveys wastewater from one pumping station service area to another pumping station service area; and



(iii). a Gravity Sewer Line that has caused or contributed to, or that Columbia knows or should know will likely cause or contribute to, capacity-related unpermitted overflows.

aa. “Major Pump Station” shall mean a pump station receiving flow from a sewer line of 15 inches in diameter or greater.

bb. “MOM” or “Management, Operations, and Maintenance” shall mean a program of accepted industry practices to properly manage, operate and maintain sanitary wastewater collection, transmission and treatment systems, investigate capacity-constrained areas of these systems, and respond to SSO events.

cc. “NPDES” shall mean the National Pollutant Discharge Elimination System authorized under Section 402 of the CWA, 33 U.S.C. § 1342.

dd. “NPDES Permit” shall mean NPDES permit number SC0020940 issued to Columbia Metro WWTP pursuant to Section 402 of the Clean Water Act, 33 U.S.C. § 1342, and any future extended, modified, or reissued permits.

ee. “Paragraph” shall mean a portion of this Consent Decree identified by an Arabic numeral.

ff. “Parties” shall mean the United States of America on behalf of EPA, the State of South Carolina by and through DHEC, and Columbia.

gg. “Plaintiffs” shall mean the United States of America on behalf of EPA and the State of South Carolina by and through DHEC.

hh. “Private Lateral” shall mean that portion of a sanitary sewer conveyance pipe that extends from the wastewater right-of-way or utility easement to the single-family, multi-family, apartment, or other dwelling unit or commercial or industrial structure to which Columbia’s wastewater service is or has been provided.

ii. “Publicly Owned Treatment Works” or “POTW” shall mean a publicly owned treatment works or POTW as defined in 40 C.F.R. § 403.3(q), and includes the WCTS and the WWTP as defined in this Consent Decree.

jj. “Pump Station” shall mean facilities comprised of pumps which lift wastewater to a higher hydraulic elevation, including all related electrical, mechanical, and structural systems necessary to the operation of the facilities.

kk. “Sanitary Sewer Overflow” or “SSO” shall mean an overflow, spill, or release of wastewater from Columbia’s Sewer System including: (a) Unpermitted Discharges; (b) overflows, spills, or releases of wastewater that may not have reached waters of the United States or the State of South Carolina; and (c) all Building Backups.

ll. “Section” shall mean a portion of this Consent Decree identified by a Roman numeral.

mm. “Sewerbasin” shall mean all hydraulically linked portions of Columbia’s Wastewater Collection and Transmission System that are tributary to a trunk sewer which directly leads to the WWTP. Each Sewerbasin is independent of other Sewerbasins. The Sewerbasins in Columbia’s WCTS are shown on the map attached as Appendix C.

nn. “Sewer System” shall mean the WCTS and the WWTP.

oo. “State” shall mean the State of South Carolina.

pp. “SORP” shall mean the Sewer Overflow Response Plan that Columbia has developed and which is attached as Appendix D to this Consent Decree.

qq. “Subbasin” shall mean a subdivision of a Sewerbasin which consists of hydraulically linked sewers that are tributary to a common point in the sewer system. Sewer system evaluation techniques are undertaken on a Subbasin basis. A Subbasin typically consists of 10,000 to 50,000 linear feet of sewer. The Subbasins in Columbia’s WCTS are shown on the map attached as Appendix C.

rr. “Subparagraph” shall mean a portion of a paragraph identified by lowercase letters.

ss. “SCPCA” shall mean the South Carolina Pollution Control Act, South Carolina Code Ann. §§ 48-1-10 *et seq.*

tt. “United States” shall mean the United States of America, acting on behalf of EPA.

uu. “Unpermitted Discharge” shall mean a discharge of pollutants which reaches waters of the United States or the State from (a) the Sewer System, (b) the WWTP through a point source not specified in an NPDES Permit, or (c) the WWTP which constitutes a prohibited Bypass.

vv. “Wastewater Collection and Transmission System” or “WCTS” shall mean the municipal wastewater collection, retention and transmission system, including all pipes, Force Mains, Gravity Sewer Lines, Pump Stations, pumps, manholes, and appurtenances thereto, which are owned or operated by Columbia and which flow to the Columbia Metro WWTP.

ww. “Wastewater Treatment Plant” or “WWTP” shall mean all facilities, devices, or systems which are owned, managed, operated, or maintained by Columbia for the storage, treatment, recycling, or reclamation of municipal wastewater, including the Columbia Metro WWTP located at 1200 Simon Tree Lane, Columbia, South Carolina, and all components of such wastewater treatment facility.

xx. “Work” shall mean all activities Columbia is required to perform under this Consent Decree.

## **V. COMPLIANCE REQUIREMENTS**

9. Obligation to Perform Work. Upon the Date of Entry, Columbia shall implement the Work pursuant to this Consent Decree. Columbia is responsible for ensuring that any contractors hired to perform Work pursuant to this Consent Decree comply with all applicable laws and with this Consent Decree. All Work shall be performed using sound engineering practices, which may include, but are not limited to, appropriate provisions of South Carolina Regulation 61-67 (wastewater construction standards); South Carolina Regulation 61-9 (discharge standards); the *Handbook: Sewer System Infrastructure Analysis and Rehabilitation*, EPA/625/6-91/030, 1991; *Existing Sewer Evaluation and Rehabilitation*, WEF MOP FD-6,



1994, Third Edition 2009; and the most recent edition of “Recommended Standards for Wastewater Facilities” by the Great Lakes-Upper Mississippi River Board of State and Provincial Public Health and Environmental Managers (commonly known as the “Ten State Standards.”).

10. Early Action Capital Improvement Projects. Subject to receiving all necessary permits and approvals, Columbia shall implement and complete the following capital and short term SSO measures:

a. Capital Improvement Program for Columbia Metro WWTP. Columbia has underway a Capital Improvement Program for the Columbia Metro WWTP, as described further on Appendix E. The projects included in this Program are: (1) Metro Headworks Project (Capital Improvement Project (“CIP”) SS6722); (2) Metro WWTP Aeration Improvements (CIP No. SS7182); (3) Disinfection Improvements at the WWTP (CIP No. SS7058); (4) Secondary Clarifier Improvements at the WWTP (CIP No. SS6871); (5) Train 2 Pump Station Improvements (CIP No. SS7155); and (6) DAF Improvements (CIP No. SS7197). These capital improvements include construction of new Equipment as well as the upgrade and rehabilitation of existing Equipment. The schedule for the Capital Improvement Program for Columbia Metro WWTP is included in Appendix E , and such schedule shall be enforceable under this Consent Decree.

b. Capital Improvement Projects for WCTS. Columbia has underway a Capital Improvement Program for the Wastewater Collection and Transmission System, as described further on Appendix F. The projects included in this Program are: (1) Broad River Pump Station

Improvements (CIP No. SS7101); (2) North Columbia Pump Station Improvements; (3) West Columbia Pump Station Improvements (CIP No. SS711501); (4) Installation of 20,000 Linear Feet of 42-inch Forcemain from West Columbia Pump Station to WWTP (CIP No. SS711502); and (5) Saluda River Pump Station Improvements (CIP No. SS7116. The schedule for the Capital Improvement Program for Columbia's WCTS is included in Appendix F, and such schedule shall be enforceable under this Consent Decree.

11. Wastewater Treatment Plant Programs. Columbia shall develop and implement the specific Wastewater Treatment Plant Programs set forth below and ensure that each Program has a written, defined purpose; a written, defined goal; is documented in writing with specific detail as required herein; is implemented by trained personnel; has established performance measures; and has written procedures for periodic review.

a. Maintenance Management System. Within one (1) year after the Date of Entry of this Consent Decree, Columbia shall submit to EPA and DHEC for review, comment, and approval a Maintenance Management System ("MMS") for the WWTP. The objectives of the MMS are to ensure that preventive and corrective maintenance is conducted at the WWTP and that WWTP equipment integral to proper operation and maintenance, treatment units, and tanks is maintained with the goal of achieving compliance with the NPDES Permit. At minimum, the MMS shall include, and Columbia shall implement, the requirements set forth in Paragraphs 11.a.(i) through (xi) below.

(i). Identification of equipment integral to proper operation and maintenance, treatment units, and tanks used in the treatment of wastewater liquids and biosolids

(hereafter referred to as “Equipment”).

(ii). Standard procedures to conduct periodic preventive maintenance of the Equipment (hereafter referred to as “Standard Maintenance Procedures”).

(iii). Standard Maintenance Procedures, which include the frequencies of preventative maintenance, necessary to ensure that Equipment is properly maintained.

(iv). Adequate training and education for maintenance personnel to perform the Standard Maintenance Procedures.

(v). Procedures for recognition of indicators that corrective maintenance on Equipment is necessary.

(vi). Procedures for the generation of work orders associated with preventive and corrective maintenance of the Equipment.

(vii). Procedures for the generation of purchase orders associated with preventive and corrective maintenance of the Equipment.

(viii). An Inventory Management System that requires Columbia to maintain:

(A) lists of critical equipment and critical spare parts for the operation of the WWTP;

(B) an inventory of critical spare parts stored at the WWTP and a list of where the remaining critical spare parts not stored at the WWTP may be obtained to

enable the repair or replacement of Equipment in a minimum amount of time and to ensure proper operation of the WWTP; and

(C) written procedures for maintaining and updating the information in the Inventory Management System.

(ix). An accessible system for tracking preventive and corrective maintenance activities and histories at the WWTP including the generation of summary reports each month that identify:

(A) Equipment failures occurring in the previous month; and

(B) the end-of-month status of preventive and corrective maintenance work orders issued or outstanding in the previous month for Equipment.

(x). Procedures to ensure that failures of Equipment and/or loss of power supply during abnormal and emergency conditions are corrected in a timely fashion so as to limit the downtime of the facility or component.

(xi). The updated WWTP Operations Program shall include an implementation schedule specifying dates and actions.

b. WWTP Operations Program. Columbia currently has a WWTP Operations Program in place. Within eighteen (18) months after the Date of Entry of this Consent Decree, Columbia shall submit to EPA and DHEC for review, comment, and approval an updated WWTP Operations Program. The goal of the updated WWTP Operations Program is to ensure that all Equipment is operated to achieve compliance with the NPDES Permit. At

minimum, the updated WWTP Operations Program shall include an Operations Plan, a Process Control Plan, and Compliance Monitoring Plan.

(i). Operations Plan. The updated WWTP Operations Program shall include an Operations Plan. At minimum, the Operations Plan shall include:

- (A) the operations manuals for all Equipment;
- (B) descriptions of the operational controls at the WWTP;
- (C) the maximum flow that each process unit may treat before effluent quality is expected to exceed NPDES Permit limits;
- (D) a peak flow operations plan;
- (E) schematics of the solids and liquids treatment processes;
- (F) a procedure for review and update on an annual basis of an organizational chart consisting of the names, positions, and telephone numbers of the operations personnel at the WWTP;
- (G) detailed procedures for the year-round disposal of biosolids which include alternative disposal methods should the primary disposal method not be employable;
- (H) a detailed operations training program for WWTP operations personnel and supervisors; and
- (I) detailed procedures for adding operating information for new Equipment into the WWTP Operations Program prior to the date on which Columbia

commences operation of that Equipment.

(ii). Process Control Plan. The updated WWTP Operations Program shall include a Process Control Plan. At minimum, the Process Control Plan shall include:

(A) Parameters for each treatment unit that is monitored for the purpose of process control, including the appropriate frequency of monitoring and guidelines for interpreting the data in order to implement modification(s) and adjustment(s) to the systems and Equipment;

(B) Tasks associated with the operation of the WWTP, including overall process control strategy and unit-specific tasks, an analysis of the level of personnel assigned to the task and the frequency and duration associated with the tasks;

(C) Procedures for unit-specific tasks and overall process control (hereafter referred to as “Standard Operating Procedures”); and

(D) Standard Operating Procedures (including emergency response plans, as necessary) for abnormal operational conditions (e.g., power outages and weather-related events) to ensure that Equipment is operated to achieve compliance with the NPDES Permit, ensure safety of all personnel, and ensure proper communication among WWTP personnel of the current operational state of the WWTP (hereafter referred to as “Contingency Operating Procedures”).

(iii). Compliance Monitoring Plan. The updated WWTP Operations Program shall include a Compliance Monitoring Plan. At minimum, the Compliance Monitoring Plan shall include:

(A) procedures for proper calibration of compliance monitoring equipment which also identify the frequencies required by the manufacturer and Columbia;

(B) procedures to ensure that representative compliance sampling is conducted at the WWTP in accordance with the requirements of NPDES permits and 40 C.F.R. Part 136;

(C) descriptions of all compliance sampling locations;

(D) schematics showing the compliance sampling locations;

(E) procedures for collecting compliance samples from the designated locations;

(F) procedures for obtaining compliance sample containers, preservatives, and/or monitoring equipment from the laboratory;

(G) procedures for collecting compliance samples in containers as described in 40 C.F.R. Part 136; and

(H) procedures to ensure that all compliance samples requiring immediate (e.g., within fifteen (15) minutes) analyses are either monitored in the field or transported to the laboratory within proper holding times for analysis.

(iv). An implementation schedule specifying dates and actions.

c. WWTP Training Program. Columbia currently has a training program in place at the WWTP. Within twenty-four (24) months after the Date of Entry of this Consent Decree, Columbia shall submit to EPA and DHEC for review, comment, and approval an

updated WWTP Training Program. Columbia shall update the Program by evaluating the personnel, tasks, equipment, and facilities associated with the operation and maintenance of the Columbia Metro WWTP. The updated Program shall include the following:

(i). WWTP Maintenance Training Program. A training program to address the methods, processes, procedures, and techniques required to perform the duties and tasks necessary for the maintenance of the Equipment. At minimum, the WWTP Maintenance Training Program shall be updated to include:

(A) Training to be provided to maintenance supervisors and personnel regarding the MMS in Paragraph 11.a. above;

(B) Schedules for the training of maintenance supervisors and personnel; and

(C) A system for tracking the training activities described in (A) and (B) above.

(ii). WWTP Operations Training Program. Columbia shall provide training to address the methods, processes, procedures, and techniques required to perform the duties and tasks necessary for the proper operation of the Equipment. At minimum, the WWTP Operations Training Program shall be updated to include:

(A) Training for operations supervisors and personnel regarding the use of the Operations Program in Paragraph 11.b. above;

(B) Training that ensures operations personnel are



knowledgeable about the Standard Operating Procedures and how to implement each task of the Standard Operating Procedures assigned to them or their subordinates efficiently and effectively on a day-to-day basis;

(C) Training that ensures all operations personnel are knowledgeable about the Contingency Operating Procedures and how to respond efficiently and effectively to atypical operational situations; and

(D) A system for tracking the training activities described in (A) through (C) above; and

(iii). An implementation schedule specifying dates and actions.

12. Management, Operations and Maintenance (“MOM”) Programs. Columbia shall develop and implement the specific MOM Programs set forth below and ensure that each MOM Program has a written, defined purpose; a written, defined goal; is documented in writing with specific detail as required herein; is implemented by trained personnel; has established performance measures; and has written procedures for periodic review.

a. Sewer Overflow Response Program. Columbia has developed and maintains a Sewer Overflow Response Plan (“SORP”), a copy of which is attached hereto as Appendix D. Columbia shall continue to implement its SORP, as may be revised by Columbia from time to time, during the term of this Consent Decree.

b. Contingency and Emergency Response Plan. Within eighteen (18) months after the Date of Entry of this Consent Decree, Columbia shall develop in consultation with DHEC and submit to EPA and DHEC for review, comment, and approval a Contingency and

Emergency Response Plan (“CERP”). The CERP shall address both routine and catastrophic emergencies. Routine emergencies include such situations as overflowing manholes, line breaks, localized electrical failure and Pump Station outages. Catastrophic emergencies include floods, tornados, earthquakes or other natural events, serious chemical spills and widespread electrical failure. The CERP shall address areas of vulnerability and determine the effect of such a failure to operations, equipment and public safety and health based upon such factors as topography, weather, sewer system size, and other site-specific factors. The CERP shall include standard forms. The CERP shall have the following components:

(i). WWTP. The WWTP component of the CERP shall establish standard operating procedures for use in emergency situations, including changes in process controls.

(ii). WCTS. The WCTS component of the CERP shall include the SORP; the evaluation of, and acquisition plan for, additional Pump Station standby power and emergency equipment needs; and the written standard operating procedures for use in specific anticipated emergency activities, which include identification of the specific actions which staff should take and the instructions for operating equipment and systems. At a minimum, the standard operating procedures shall: identify criteria for initiating and ceasing the anticipated activities; identify the appropriate service/repair equipment and sources for that equipment; and describe the emergency planning for, and emergency use of, the following: stand-by power (e.g., generators or dual power feeds), portable pumps, maintenance equipment (e.g., vacuum truck, jet washing truck and/or combination truck), and each Pump Station.

(iii). Public Notification of Emergencies. In addition to the reporting

requirements set forth in Section IX (Reporting Requirements), Columbia shall establish, in coordination with DHEC:

(A) criteria to be used as the basis for immediately notifying the public and other impacted entities, such as users with a downstream water intake, of an emergency situation caused by an SSO, diversion, Bypass, or effluent limit violation;

(B) a list identifying, by name, phone number and pager number, all Columbia staff who are responsible for notifying the public;

(C) a list identifying, by name and phone number, all public contacts, including local media outlets, who must be contacted during an emergency situation;

(D) a list identifying Columbia staff who are authorized to make public statements during emergency situations; and

(E) pre-scripted news releases for various types of emergency situations.

(iv). Notification of Regulatory Authorities. In addition to the notification requirements set forth in the NPDES Permit, and the reporting requirements set forth in Section IX (Reporting Requirements), Columbia shall establish, in coordination with DHEC:

(A) criteria to be used as the basis for immediately notifying DHEC of any emergency situation caused by an SSO, diversion, Bypass, or effluent limit violation; (B) a list identifying, by name, phone number and pager number, all Columbia staff who are responsible for notifying DHEC;

(C) a list identifying, by name and phone number, all officials who must be contacted; and (D) standard reporting forms.

(v). An implementation schedule specifying dates and actions.

c. WCTS Training Program. Within eighteen (18) months after the Date of Entry of this Consent Decree, Columbia shall submit to EPA and DHEC for review, comment, and approval a WCTS Training Program. Columbia shall develop the Program by evaluating the personnel, tasks, equipment, and facilities associated with the operation and maintenance of Columbia's WCTS. The Program shall include, and Columbia shall implement:

(i). General Training. Columbia shall provide general training to address tasks undertaken by Columbia's wastewater personnel. General training would include, for example, employee orientations, training in the basic principles of wastewater collection and transmission, and training in the rules and regulations affecting Columbia's Wastewater Maintenance Division. The general training component of the Program shall provide the content of the initial training, and the frequency and content of the refresher training, to be required for all personnel responsible for management, operations, or maintenance of Columbia's WCTS.

(ii). Position Specific Training. Columbia shall provide training for tasks undertaken by Columbia's wastewater personnel to address the methods, processes, procedures, and techniques required to perform the duties and tasks necessary for the proper operation and maintenance of the collection and transmission system. Collection system training would include, as appropriate, training in equipment operation, pipe installation/replacement, pipe cleaning, pipe inspection, and reading as-built drawings. Transmission system training would include, as appropriate, training in equipment operation, pump/ejector inspection, pump/ejector maintenance, and pump/ejector repair. Columbia's collection system training and transmission system training program shall include:

(A) identification of the related tasks, equipment, and facilities;

(B) description of the technical knowledge necessary to properly conduct the individual tasks and properly operate the individual equipment and facilities;

(C) description of the underlying purposes and technical reasons for conducting the individual tasks or operating the individual equipment and facilities;

(D) standard procedures which personnel shall follow when conducting the individual tasks or operating the individual equipment and facilities;

(E) the content of the initial training, and the frequency and content of the refresher training, to be required for personnel conducting the individual tasks, or operating the individual equipment and facilities; and

(F) training designed to provide trainees with a thorough understanding of the individual procedures, underlying technical reasons, and underlying purposes associated with the individual tasks they may conduct, or the specific equipment and facilities they may operate, and to provide this in a consistent manner to all trainees.

(iii). Tracking. The Training Program shall include a description of the common data management system to be used for tracking personnel participation in, and completion of, the initial general training, collection system training, and/or transmission system training, and the corresponding refresher training.

(iv). Implementation Schedule. The Training Program shall include an

implementation schedule specifying dates and actions.

d. Information Management System Program. Within eighteen (18) months after the Date of Entry of this Consent Decree, Columbia shall submit to EPA and DHEC for review, comment, and approval an Information Management System (IMS) Program. The IMS Program shall include, but may not be limited to the following: a description of what information is entered into the system, how it is entered and by what means it is recorded; types of work reports prepared and submitted, including examples; a description of the management reports generated from the input data (i.e. work reports), including examples; standard forms used by both field personnel and management for the program, where applicable; a detailed description of how the records are maintained; if computer software is utilized, a description of the software used with cited references for software training and procedures for utilizing the software; and a procedure for periodic quality assurance/quality control checks of the system. The Program shall include the following sub-programs:

(i). Management IMS. The IMS Program shall include a Management IMS to provide WCTS managers guidance and instruction to adequately evaluate operations, maintenance, customer service, and system rehabilitation activities so that overall system performance can be determined and WCTS planning can be conducted.

(ii). Operations IMS. The IMS Program shall include an Operations IMS to provide managers and field supervisors the guidance to adequately track scheduled operational activities and to enhance operational performance. The system shall utilize operating reports and standard operation forms used by field personnel and provide for field supervisor

review. While the Operations IMS need not be computer based, it shall be capable of feeding information into the Management IMS.

(iii). Maintenance IMS. The IMS Program shall include a Maintenance IMS to provide managers and field supervisors the guidance to adequately track scheduled maintenance activities and to enhance maintenance performance. The system shall utilize maintenance reports and standard maintenance forms used by field personnel and for field supervisor review. While the Maintenance IMS need not be computer based, it shall be capable of feeding information into the Management IMS.

(iv). Complaint Tracking IMS. The IMS Program shall include a Complaint Tracking IMS to provide managers the guidance to adequately assess and manage complaint information. The system shall utilize standard complaint forms used by personnel and provide for supervisor review. While the Complaint Tracking IMS need not be computer based, it shall be capable of feeding information into the Management Programs IMS.

(v). An implementation schedule specifying dates and actions.

e. Capacity Assurance Program. Within one hundred and eighty (180) Days after EPA approval of the Hydraulic Model Report, Columbia shall submit to EPA and DHEC for review, comment, and approval a Capacity Assurance Program (“CAP”). The CAP shall identify each Sewerbasin with insufficient capacity under peak wet weather, average conditions, or both. It shall also analyze all portions of the WCTS that have experienced SSOs either due to, or exacerbated by, an excessive hydraulic contribution. The CAP shall assess peak flow capacity of all major Sewer System components for existing and proposed flows. At minimum, the CAP

shall include, and Columbia shall implement, the requirements set forth in Paragraphs 12.e.(i) through 12.e.(iii), below.

(i). Adequate Capacity Certifications. Except as otherwise provided in Paragraphs 12.e.(ii)(F) through 12.e.(ii)(I), below, after sixty (60) Days following EPA's approval of the CAP, Columbia shall authorize a new sewer service connection, or additional flow from an existing sewer service connection, only after it certifies that the analysis procedures contained in the approved CAP have been used and that Columbia has determined, based on those procedures, that there is Adequate Treatment Capacity, Adequate Transmission Capacity and Adequate Collection Capacity as set forth below. Notwithstanding the foregoing, the standards contained in the Capacity Assurance Program shall not be construed as standards for the ultimate design or rehabilitation of Columbia's WCTS.

(A) Treatment Capacity. For the purposes of Columbia's Capacity Assurance Program, "Adequate Treatment Capacity" shall exist when the WWTP would not be in "non-compliance" for quarterly reporting as defined in 40 C.F.R. § 123.45, Appendix A, if the WWTP were to receive the flow from the new connection or the increased flow from an existing sewer service connection(s), combined with the flow predicted to occur from all other authorized sewer service connections (including those which have not begun to discharge into the WCTS).

(B) Transmission Capacity. For the purposes of Columbia's Capacity Assurance Program, "Adequate Transmission Capacity" shall exist when each Pump Station through which the proposed additional flow would pass has the capacity to transmit,



with its largest pump out of service, the existing one (1) hour peak flow passing through such Pump Station, plus the additional one (1) hour peak flow predicted to occur from the new connection(s) or from the increased flow from an existing sewer service connection(s), plus the additional one (1) hour peak flow predicted to pass through such Pump Station from all other authorized sewer service connections which have not begun to discharge into the WCTS.

(C) Collection Capacity. For the purposes of Columbia's Capacity Assurance Program, "Adequate Collection Capacity" shall exist when each Gravity Sewer Line through which the proposed additional flow would pass has the capacity, without causing a Surcharge Condition, to carry the existing one (1) hour peak flow passing through such Gravity Sewer Line, plus the additional one (1) hour peak flow predicted to occur from the new connection(s) or from the increased flow from an existing sewer service connection(s), plus the additional one (1) hour peak flow predicted to pass through such Gravity Sewer Line from all other authorized sewer service connections which have not begun to discharge into the WCTS.

(D) "One (1) Hour Peak Flow." For purposes of Columbia's Capacity Assurance Program, the term "one (1) hour peak flow" shall mean the greatest flow in a sewer averaged over a sixty (60) minute period at a specific location expected to occur as a result of a representative 2 year-24 hour storm event.

(E) "Surcharge Condition." Except as otherwise set forth in Paragraph 12(e)(i)(F), below, the term "Surcharge Condition" shall mean:

(1) For two years from the date of EPA's approval of the CAP, the condition that exists when the supply of wastewater resulting from the one (1) hour peak flow is greater than

the capacity of the pipes to carry it and the surface of the wastewater rises to an elevation within two (2) feet of the rim of any manhole, and the gravity sewer pipe is under pressure or head, rather than at atmospheric pressure. Columbia agrees to not construct additional manholes and to not increase the elevation of existing manholes except to ensure that the elevation is no higher than five (5) feet above the Base Flood elevation as that term is defined at 44 C.F.R. § 59.1.

(2) After two years from the date of EPA's approval of the CAP, the condition that exists when the wastewater resulting from the one (1) hour peak flow is greater than the capacity of the pipes to carry it and the surface of the wastewater in manholes rises to an elevation greater than twenty-four (24) inches above the top of the pipe or within two (2) feet of the rim of the manhole, and the gravity sewer pipe is under pressure or head, rather than at atmospheric pressure, unless Columbia has, pursuant to Paragraph 12.e.(ii)(A), identified that pipe segment and manhole as designed to operate in that condition, in which case the identified level of surcharge for that pipe segment and manhole will be used to define a Surcharge Condition.

(F) Exception to Definition of Surcharge Condition. Notwithstanding the definition of "Surcharge Condition" in Paragraph 12(e)(i)(E), any rise in elevation above the top of the pipe shall be considered a Surcharge Condition if the manhole has experienced a capacity-related wet weather SSO during the previous twelve (12) month period (excluding those SSOs caused by severe natural conditions such as hurricanes, tornados, widespread flooding, earthquakes, or rainfall events greater than a representative 2 year-24 hour storm event), unless Columbia can certify that the cause of the SSO has been corrected through improvements to the WCTS.

(ii). Capacity Assurance Program Content

(A) The CAP shall identify the technical information, methodology and analytical techniques to be used by Columbia to determine Adequate Treatment Capacity, Adequate Transmission Capacity and Adequate Collection Capacity. Protocols for evaluating adequate capacity shall include identification of modeling software, standard design flow rate rules of thumb regarding pipe roughness, manhole head losses, as-built drawing accuracy (distance and slope), and water use (gallons per capita per day); projected flow impact calculation techniques; and flow metering. Columbia may identify sewer line segments which have been specifically designed and constructed to operate under surcharge conditions (e.g., with welded or bolted joints) and identify the level of acceptable surcharge for those segments.

(B) The CAP shall identify the technical information, methodology and analytical techniques, including the model or software, by which Columbia will calculate the net (cumulative) increase or decrease in volume of wastewater introduced to the WCTS as a result of Columbia's authorization of new service connections and increases in flows from existing connections and the completion of specific projects that add or restore capacity to the WCTS or WWTPs ("Capacity Enhancing Projects"), specific projects that reduce peak flow through removal of I/I ("I/I Projects"), and permanent removal of sewer connections ("Removal of Connections").

(C) The CAP shall identify the process by which Columbia will integrate its certification of Adequate Treatment Capacity, Adequate Transmission Capacity and

Adequate Collection Capacity into the authorization of new sewer service connections and increases in flow from existing connections.

(D) The CAP will describe the CAP Information Management System to be used to track the accumulation of available capacity, from completion of Capacity Enhancing Projects, I/I Projects and Removal of Connections, and the reduction in capacity from authorized increases in flow from new and existing sewer service connections.

(E) Capacity Certifications. Except as otherwise provided in Paragraphs 12(e)(ii)(F), (G), (H), and (I), below, after sixty (60) Days of EPA's approval of the CAP, Columbia may authorize new sewer service connections, or additional flow from existing sewer service connections, only after it certifies that the analysis procedures contained in the approved CAP have been used and that Columbia has determined, based on those procedures, that there is Adequate Treatment Capacity, Adequate Transmission Capacity and Adequate Collection Capacity. All certifications pursuant to this Paragraph 12.e.(ii)(E) shall be made by a registered professional engineer (P.E.) in the State of South Carolina and shall be approved by a responsible official of Columbia as defined by 40 C.F.R. § 122.22(b). Columbia shall maintain Capacity Assurance Program certifications, and all data on which the certifications are based, in its offices for inspection by EPA and DHEC. EPA and DHEC may request, and Columbia shall provide, any and all documentation necessary to support any certification made by Columbia pursuant to the approved CAP, and make available, to the extent possible, individuals providing such certifications to meet with EPA and DHEC.

(F) Minor Sewer Connections. The CAP may include

provisions for authorization of Minor Sewer Connections. For the purposes of the CAP, a “Minor Sewer Connection” is a connection with an average flow not to exceed four thousand (4,000) gallons per day. For minor sewer service connections, Columbia may elect to perform a quarterly capacity analysis for each Sewerbasin or Subbasin by certifying that the Sewerbasin or Subbasin has Adequate Treatment Capacity, Adequate Transmission Capacity, and Adequate Collection Capacity to carry existing flows and the additional flows generated by all such minor sewer service connections projected to be approved since the last capacity analysis. For any Sewerbasin or Subbasin which can be so certified, Columbia may approve these projected minor sewer service connections without performing individual capacity analysis for each connection.

(G) Capacity for Treatment, Transmission, and Collection in Lieu of Certification. Columbia may authorize a new sewer service connection, or additional flow from an existing sewer service connection, even if it cannot satisfy the requirements of Paragraph 12.e.(ii)(E), above, provided Columbia certifies that all of the following provisions, where applicable, are satisfied:

- (1) Columbia is in substantial compliance with this Consent Decree.
- (2) The sewer lines which will convey the proposed additional flow from new or existing sewer service connections have not experienced dry weather SSOs due to inadequate capacity within the previous twelve (12) months; or, in the alternative, the causes of any dry weather SSOs due to inadequate capacity have been eliminated.
- (3) Columbia has identified the sewer line segment(s), Pump Station(s) and/or wastewater treatment systems that do not meet the conditions for certification

of Adequate Treatment Capacity, Adequate Collection Capacity and/or Adequate Transmission Capacity.

(4) Columbia shall have completed, after June 10, 2010, and prior to the time the proposed additional flow from new or existing sewer connections is introduced into the WCTS, specific Capacity Enhancing Projects, I/I Projects and/or Removal of Connections which will add sewer capacity or reduce peak flows to the identified sewer line segment(s), lift station(s), and/or wastewater treatment system(s) in accordance with the requirements set forth below:

*i.* Where Columbia has undertaken specific Capacity Enhancing Projects that provide for additional off-line storage and/or specific Removal of Connections to satisfy the requirements of this Paragraph 12.e.(ii)(G)(4), the estimated added capacity resulting from such projects must be equal to or greater than the estimated amount of any proposed additional flow.

*ii.* Where Columbia has undertaken specific Capacity Enhancing Projects, other than those that provide for additional off-line storage, to satisfy the requirements of this Paragraph 12.e.(ii)(G)(4), the estimated reduction in peak flows or added capacity resulting from such projects must exceed the estimated amount of any proposed additional flow by a factor of 2:1.

*iii.* Where Columbia has undertaken specific I/I Projects to satisfy the requirements of this Paragraph 12.e.(ii)(G)(4), the estimated reduction in peak flows or added capacity resulting from such projects must exceed the estimated amount of any proposed additional flow by a factor of 3:1.

(5) Commencing one year after EPA approval of the CAP and annually thereafter, Columbia has performed a review of specific Capacity Enhancing Projects and I/I Projects undertaken to determine if actual added capacity and peak flow reductions are in line with what Columbia originally estimated for such projects; and Columbia has used the results of this review to adjust future estimates as necessary.

(6) Any new sewer service connection or increase in flow to an existing connection authorized prior to the completion of a necessary added capacity or peak flow reduction project as set forth above shall be conditioned upon completion of such project prior to the time that the new sewer service connection or flow increase is introduced into the WCTS.

(H) Essential Services. The CAP may contain provisions for Columbia to authorize a new sewer service connection, or additional flow from an existing sewer service connection, in cases where there is not Adequate Transmission Capacity, Adequate Collection Capacity and/or Adequate Treatment Capacity for health care facilities, public safety facilities and public schools and, subject to EPA review and approval, for government facilities; and in those cases where a pollution or sanitary nuisance condition exists, as determined by the Richland or Lexington County Health Department, as the result of a discharge of untreated wastewater from an on-site septic tank. All such new service connections, or additions to flow from an existing connection, shall be tracked in the CAP Information Management System.

(I) Existing Illicit Connections. The CAP may contain provisions for Columbia to authorize a new sewer service connection, or additional flow from an existing sewer service connection in cases where there is not Adequate Transmission Capacity and/or Adequate Collection Capacity and/or Adequate Treatment Capacity for any illicit connections or discharge of wastewater to the stormwater system. All such new service connections or additions to flow from an existing connection created after the Date of Entry that result from the elimination of such illicit connections or discharges shall be tracked in the CAP Information Management System.

(iii). Capacity Procedures Prior to CAP Approval. Within ninety (90) Days after the Date of Entry of this Consent Decree, Columbia shall establish a list of all authorized new sewer service connections or increases in flow from existing service connections, which flows have not yet been introduced into the WCTS. The following information shall be recorded for each such authorized connection: street address, estimated average daily flow, estimated peak flow, Sewerbasin or Subbasin, date authorized, and estimated Calendar Quarter when the additional flow from the connection will begin. Columbia shall update and maintain this list as necessary until full implementation of the CAP, as approved by EPA. In addition, upon execution of this Consent Decree and until EPA approves the CAP as required by Paragraph 12.e., Columbia agrees to continue to implement its current capacity program.

f. Sewer Mapping Program. Columbia currently has a sewer mapping program. Within sixty (60) days after the Date of Entry of this Consent Decree, Columbia shall submit to EPA and DHEC for review, comment, and approval a Sewer Mapping Program to update its Sewer System maps and update the capabilities and procedures for utilization of Columbia's existing Geographic Information System ("GIS") map of Columbia's WCTS. At minimum, the Sewer Mapping Program shall:

- (i). enable Columbia to produce maps of the WCTS using GIS technology;
- (ii). be designed in such a manner so as to allow electronic integration with Columbia's computer-based collection system model and computer-based operations and maintenance information management system;



(iii). enable Columbia to produce maps showing the location of all manholes, Gravity Sewer Lines, Pump Stations, Force Mains, valves, inverted siphons and the WWTP;

(iv). enable Columbia to produce maps capable of integrating electronically the locations of sewer service connections on lines that are televised;

(v). enable Columbia to produce maps that include attribute data for Columbia's WCTS including, but not limited to, size, material, estimated age or age range, slope, invert elevation, and rim elevation;

(vi). enable Columbia to produce maps that delineate the spatial boundaries of all Sewerbasins and Subbasins;

(vii). enable Columbia to produce maps that can integrate electronically available maps that show the location of surface streets and street addresses, permitted FOG customers, surface water bodies and political boundaries;

(viii). enable Columbia to produce maps in a manner that will allow use by all Sewer System operation and maintenance crew leaders in the field;

(ix). allow entry and mapping of work orders to identify and track problems geographically such as stoppages, service interruptions, and SSOs, and to assist in the planning and scheduling of maintenance;

(x). include written standard operating procedures for use of the program, the acquisition and entry of updated mapping data for new assets or changes to existing

assets, and updates to system software;

(xi). include locations of each permitted FOG establishment; and

(xii). include a schedule for the completion of the electronic mapping of each Sewerbasin in Columbia's WCTS.

g. Fats, Oil, and Grease ("FOG") Management Program. Columbia has developed and maintains a FOG Management Program, a copy of which is attached hereto as Appendix G. Columbia will continue to implement its FOG Management Program, as revised by Columbia from time to time, during the term of this Consent Decree.

h. Transmission System Operations and Maintenance Program.

Within one (1) year after the Date of Entry of this Consent Decree, Columbia shall submit to EPA and DHEC for review, comment, and approval a Transmission System Operations and Maintenance Program ("TSOMP"). The goal of the TSOMP is to facilitate proper operation and maintenance activities associated with the Pump Stations and Force Mains within the WCTS. At minimum, the TSOMP shall include, and Columbia shall implement, the requirements set forth in Paragraph 12.h.(i). through (x). below.

(i). Means and modes of communication between Pump Stations, field crews, and supervising staff.

(ii). Technical specifications of each Pump Station within the WCTS.

(iii). Columbia currently has a Pump Station monitoring system which continuously monitors, reports, and transmits information for each Pump Station. The TSOMP

shall provide that Columbia will continue to operate and maintain Supervisory Control and Data Acquisition (“SCADA”) systems at all Pump Stations with a rated capacity of greater than 1,000 gallons per minute as identified on Appendix H, attached hereto and incorporated herein by reference. In addition, with the goal of eliminating future SSOs due to Pump Station failure(s), Columbia shall evaluate the need for installation of SCADA systems at all other Pump Stations, and install them where necessary in accordance with the approved TSOMP implementation schedule required under paragraph 12(h)(x) .

(iv). Written preventive operations and maintenance schedules and procedures for the following routine activities:

(A) Service and calibration of instrumentation such as flow meters, liquid level sensors, alarm systems, elapsed time meters, and remote monitoring equipment.

(B) Inspection and service for air release valves.

(C) Predictive (non-physical) and/or physical inspection and service for all Pump Stations including, but not limited to:

(1) reading, recording and maintaining records of information from the elapsed time meters and pump start counters;

(2) observing and documenting wet well conditions, including grease and/or debris accumulation;

(3) checking and re-setting, as necessary to improve system

performance, wet well pumping points (e.g. floats);

- (4) checking, recording and maintaining records of system pressure(s);
- (5) checking SCADA and/or alarm components;
- (6) checking stand-by power sources; and
- (7) identifying maintenance needs and any emergency planning needs.

(D) Engineering evaluation of Force Mains and Pump Stations for potential sulfide and corrosion control needs. The TSOMP shall require, and Columbia shall generate, a summary report of findings with the sulfide and corrosion control method(s) and the schedule for implementation of selected measures, where applicable.

(E) Inspection of Force Main easements, including inspection of creek crossings, stream bank encroachment toward Force Mains, and easement accessibility (including the need to control vegetative growth or encroachment of man-made structures or activities that could threaten the integrity of the affected Force Mains). Inspections shall include written reports, and where appropriate, representative photographs or videos of appurtenances being inspected (Force Mains, creek crossings, etc.). The TSOMP shall require inspectors to promptly report any observed SSOs, and any evidence of SSOs which may have occurred since the last inspection, to their area supervisors and document the findings. Columbia shall report any observed SSO in accordance with the SORP and the NPDES Permit.

(F) A schedule for the maintenance of easements.

(G) Resource commitments such as staffing, contractual support and equipment.

(v). Data attributes for the Sewer Mapping Program allowing program data to be compared in Columbia's GIS system against other pertinent data such as the occurrence of SSOs, including repeat SSO locations, and permit violations.

(vi). An inventory management system that requires Columbia to maintain:

(A) Lists of critical equipment and critical spare parts.

(B) An inventory of the critical spare parts and critical equipment stored at Columbia's facilities, and a list of where the remaining critical spare parts and critical equipment not stored at Columbia's facilities may be obtained to allow repairs in a reasonable amount of time; and

(C) Written procedures for updating the critical spare parts and equipment inventories in the inventory management system.

(vii). A common information system that Columbia will use to track implementation of the TSOMP, track maintenance activities (including Pump Station equipment histories), and track management, operation, and maintenance performance indicators.

(viii). The key performance indicators ("KPIs") Columbia will track to measure performance of the WCTS using the information system referenced in Paragraph 12.h.(vii) above. These KPIs shall include, but are not limited to, the number of SSOs related to

Force Mains per mile of Force Main and/or the number of SSOs related to Pump Stations per number of Pump Stations; and maintenance activities tracked by type (corrective, preventive, and emergency).

(ix). Reports which list equipment problems and the status of work orders generated during the prior month.

(x). An implementation schedule specifying dates and actions.

i. Gravity Sewer System Operation and Maintenance Program. Within eighteen (18) months after the Date of Entry of this Consent Decree, Columbia shall submit to EPA and DHEC for review, comment, and approval, a Gravity Sewer System Operation and Maintenance Program (“GSOMP”) with the goal of eliminating future SSOs, particularly those caused by FOG, roots and/or debris obstructions. At a minimum, the GSOMP Program shall include, and Columbia shall implement, the requirements set forth in Paragraph 12.i.(i) through (xii) below.

(i). Written procedures for inspection and maintenance of Columbia’s Gravity Sewer systems (i.e., Gravity Sewer Lines, manholes, inverted siphons, etc.).

(ii). Written preventive operations and maintenance schedules and procedures including, but not be limited to, the following routine activities:

(A) Inspection and maintenance of all Gravity Sewers, manholes and inverted siphons.

(B) Observing and documenting Gravity Sewer, manhole and

inverted siphon conditions, including grease, roots and/or debris accumulation.

(C) Identifying and documenting maintenance needs and any emergency planning needs.

(D) Scheduling preventive maintenance work/cleaning on a WCTS-wide basis. At a minimum, Columbia shall prioritize, inspect, and, if necessary, clean its Gravity Sewers, manholes and inverted siphons on a regular basis (i.e. such that, while priority portions of the WCTS may be inspected with more frequency, the entire Gravity Sewer system is inspected, and cleaned where necessary, at a frequency designed to prevent future SSOs).

(iii). Engineering evaluation of potential sulfide and corrosion control needs. The GSOMP shall require, and Columbia shall generate, a summary report of findings with the sulfide and corrosion control methods and the schedule for implementation of selected measures, where applicable.

(iv). Inspection of Gravity Sewer, manhole, and inverted siphon easements, including inspection of: creek crossings, stream bank encroachment toward Gravity Sewers, manholes and inverted siphons, and easement accessibility (including the need to control vegetative growth or encroachment of man-made structures or activities that could threaten the integrity of the affected Gravity Sewer, manholes or inverted siphon). Inspections shall include written reports, and where appropriate, representative photographs or videos of appurtenances being inspected (Gravity Sewers, manholes, inverted siphons, creek crossings, etc.). The GSOMP shall require inspectors to promptly report any observed SSOs to their area supervisors and to record any evidence of SSOs which may have occurred since the last inspection.

Columbia shall report any observed SSO in accordance with the SORP and the NPDES Permit.

(v). A schedule for the maintenance of easements.

(vi). A description of resource commitments such as staffing, contractual support and equipment.

(vii). Data attributes for the Sewer Mapping Program allowing program data to be compared in Columbia's GIS system against other pertinent data such as the occurrence of SSOs, including repeat SSO locations, and permit violations.

(viii). An inventory management system that requires Columbia to maintain:

(A) Lists of critical equipment and critical spare parts;

(B) An inventory of the critical spare parts and critical equipment stored at Columbia's facilities, and a list of where the remaining critical spare parts and critical equipment not stored at Columbia's facilities may be obtained to allow repairs in a reasonable amount of time; and

(C) Written procedures for updating the critical spare parts and equipment inventories in the inventory management system.

(ix). A common information system that Columbia will use to track implementation of the GSOMP, track maintenance activities, and track management, operation, and maintenance performance indicators.



(x). The key performance indicators (“KPIs”) Columbia will track to measure performance of the WCTS using the information system referenced in Paragraph 12.i.(ix). above. These KPIs shall include, but are not limited to:

(A) The linear footage of Gravity Sewer inspections, the linear footage of Gravity Sewers cleaned, the number of manholes inspected, the number of manholes cleaned/maintained, the number of inverted siphons inspected, the number of inverted siphons cleaned/maintained and the number of SSOs per mile of Gravity Sewer; and

(B) Maintenance activity tracked by type (corrective, preventive, and emergency).

(xi). Reports which list equipment problems and the status of work orders generated during the prior month.

(xii). An implementation schedule specifying dates and actions.

j. Financial Analysis Program. Within eighteen (18) months after the Date of Entry of this Consent Decree, Columbia shall submit to EPA and DHEC for review, comment, and approval a Financial Analysis Program which establishes and tracks the sufficiency of funds for operations and maintenance, capital projects financing, and debt service coverage associated with the WCTS. At minimum, the Financial Analysis Program shall include, and Columbia shall implement, the requirements set forth in Paragraph 12.j.(i) through (v).

(i). Cost Analysis. Protocols to regularly analyze and project future utility management, operations, and maintenance costs integral to proper management, operation,

and maintenance of the WCTS and WWTP. The cost analyses should include, at a minimum: capital infrastructure improvements; staffing levels; replacement of equipment and materials integral to the proper management, operation and maintenance of the WCTS and WWTP; outsourced activities; and services provided by organizational departments or agencies outside Columbia's Department of Utilities and Engineering.

(ii). Capital Improvement Financing Program. Protocols to analyze, project, plan, and finance capital improvement needs established through engineering studies; WCTS condition assessments; historical WCTS management, operations, and maintenance cost data; and sound sewer infrastructure asset management programs. Capital improvement financing should be planned using a five (5) year planning horizon with annual updates.

(iii). Budget and Customer Rate Setting Analysis. The Financial Analysis Program shall project the annual utility budget and customer rates periodically. The program should predict the budget and funding provided by customer rates that will meet the cost and financing needs for the management, operation, and maintenance of the WCTS as identified pursuant to the procedures set forth in Subparagraph j.(i) through (ii) above.

(iv). The ability to directly track and report operation and maintenance costs by the type of activity (corrective, preventative, and emergency) and capital improvement costs.

(v). An implementation schedule specifying dates and actions.

13. Satellite Sewer System Agreements. Within one (1) year after the Date of Entry

of this Consent Decree, Columbia shall submit to EPA and DHEC for review, comment, and approval a proposed form of Satellite Sewer System Agreement for new or the renewal of existing agreements that cover the collection, conveyance and treatment of sewage by Columbia from satellite sewer systems as that term is defined in South Carolina Regulation 61-9.122.2.

The Parties acknowledge that DHEC continues to be responsible in all respects for enforcing the requirements of any state operating permits for satellite sewer systems. Columbia shall not be responsible for enforcement of any such permits or for management or oversight of any such satellite sewer systems.

a. At minimum, the form of Satellite Sewer System Agreement shall include the following:

(i). Requirements on the satellite sewer system to properly manage, operate and maintain its sewage collection and conveyance systems so as to minimize peak flows into Columbia's Sewer System by excluding, to the maximum practicable extent, the intrusion of surface and ground water and other extraneous flows.

(ii). Requirements on the satellite sewer system to ensure compliance with the legal authorities and procedures required in 40 CFR Section 403.8(f) with regard to equivalent control, monitoring and enforcement of non-domestic dischargers into Columbia's Sewer System from satellite sewer systems. Columbia should consider the "Multijurisdictional Pretreatment Programs Guidance Manual" published by EPA (833-B-94-005, June 1994) when developing these requirements.

(iii). Provisions addressing the term or life of these agreements;

mechanisms for appropriate modification of the agreements; and mechanisms for enforcement of the agreements such as provisions permitting termination of the agreement and physical disconnection from Columbia's Sewer System within a reasonable time not exceeding two (2) years upon the failure of the satellite sewer system to comply with its management, operations and maintenance obligations.

b. When any of Columbia's currently existing agreements expire or terminate, Columbia may, but shall not be required to, renew any such agreement or enter into a new agreement covering the collection, conveyance and treatment of sewage from such satellite sewer systems. In the event Columbia does renew such an agreement or enters into any such new agreement, each agreement shall be consistent with the form of Satellite Sewer System Agreement. If the owner/operator of a satellite sewer system refuses to sign a Satellite Sewer System Agreement that is consistent with the approved form of Satellite Sewer System Agreement, Columbia will notify EPA.

14. Continuing Sewer Assessment Program ("CSAP") for the WCTS

a. Within six (6) months after the Date of EPA and DHEC approval of the Sewer Mapping Program required under Paragraph 12.f. of this Consent Decree, Columbia shall submit to EPA and DHEC for review, comment, and approval a Continuing Sewer Assessment Program ("CSAP") that provides for an analysis of Columbia's WCTS infrastructure. The approved CSAP shall be implemented by Columbia in accordance with the schedules contained therein, and in accordance with the deadlines established in this Paragraph. The CSAP shall establish procedures for setting priorities and schedules for undertaking the continual assessment

of the WCTS using, as appropriate, the methods described in Paragraphs 14.b. (i) through (ix), below, and other appropriate methods identified by Columbia. Columbia shall develop these priorities and schedules taking into consideration factors including, but not limited to: age and type of materials; the nature and extent of customer complaints; flow monitoring, including flow isolation studies; locations and causes of SSOs; any remediation work already ongoing; field crew work orders; any preliminary sewer assessments, such as midnight flow monitoring; and any other relevant information. Where Columbia's implementation of the CSAP results in a determination that a Private Lateral is a source of I/I to the WCTS or is a source of a release, Columbia shall notify the property owner of its determination but shall not be responsible for repairs to the Private Lateral. For purposes of being able to develop the Infrastructure Rehabilitation Report set forth in Paragraph 16 below, the schedules set forth in the CSAP shall provide for the major components of the WCTS (to include all pipes 15 inches in diameter or larger and their appurtenances, such as manholes and Pump Stations) to be assessed at least once by no later than 24 months from the date of EPA/DHEC approval of the CSAP. The schedules set forth in the CSAP shall also provide for the remainder of the entire WCTS to be assessed at least once by no later than 60 months from the date of EPA/DHEC approval of the CSAP.

b. At a minimum, the CSAP shall include, and Columbia shall have the ability to implement, the assessment methods set forth in Paragraphs 14.b.(i) through (ix), below. When implementing the CSAP to assess specific portions of the WCTS, Columbia shall use methods that are appropriate for the portion of the WCTS being assessed.

(i) Physical Condition. Standard Procedures for evaluating the physical condition of the WCTS, including, but not limited to, consideration of age, construction

material and durability.

(ii) Dyed Water Flooding. Standard procedures for conducting dyed water testing to locate sources of I/I to the WCTS ("Dyed Water Flooding"). The Dyed Water Flooding component shall include standard forms for recording information derived from dyed water testing.

(iii) Corrosion Defect Identification. Standard procedures for inspecting and identifying sewer infrastructure that is either corroded or at risk of corrosion ("Corrosion Defect Identification"). This Corrosion Defect Identification component shall include a system for prioritizing repair of corrosion defects, corrosion identification forms, and procedures for a corrosion defect analysis.

(iv) Routine Manhole Inspection. Standard procedures and frequencies for routine inspection of manholes within the WCTS ("Routine Manhole Inspection"). This Routine Manhole Inspection component shall include manhole inspection forms and procedures for a manhole defect analysis, and may provide for less frequent inspection of newer manholes.

(v) Flow Monitoring. Standard procedures for routine flow monitoring during dry and wet weather to support engineering analyses related to WCTS capacity and peak flow studies ("Flow Monitoring"). Dry weather monitoring shall be carried out so as to allow the characterization of base flows and I/I rates. Wet weather monitoring shall be conducted periodically during events of sufficient duration and intensity that cause significant I/I into the WCTS. This Flow Monitoring component shall identify areas susceptible to I/I into the WCTS. This Flow Monitoring Program shall also establish, and Columbia shall implement,

a process for determining the number and locations of permanent and temporary flow meters; a program for sewer cleaning associated with flow monitoring; and a procedure for adequate rainfall measurement. The Flow Monitoring Program will contain an initial determination of the number and location of permanent and temporary flow meters, with a map showing such locations.

(vi) Video Inspection. Standard procedures for routine use of closed circuit television (“CCTV”) and/or zoom camera video inspections to support sewer assessment activities, including procedures for video-assisted cleaning and a process for the retention and access of video data.

(vii) Gravity System Defect Analysis. Standard procedures for analysis of Gravity Sewer Line defects (“Gravity Sewer Line Defect Analysis”). This Gravity Sewer Line Defect Analysis component shall establish standard defect codes; defect identification procedures and guidelines; and a standardized process for cataloging Gravity Sewer Line defects.

(viii) Smoke Testing. Standard procedures for smoke testing of Gravity Sewer Lines to identify sources of I/I to the WCTS, including cross connections and other unauthorized connections (“Smoke Testing”). This Smoke Testing component shall include establishing and implementing smoke testing forms and procedures for smoke testing defect analysis.

(ix) Pump Station Performance and Adequacy. Standard procedures for the evaluation of Pump Station performance and Pump Station adequacy (“Pump Station Performance and Adequacy”), including:

(A) The use of pump run time meters; pump start counters; computation of Nominal Average Pump Operating Time ("NAPOT"); root cause failure analysis protocols; and appropriate remote sensing such as Supervisory Control and Data Acquisition ("SCADA").

(B) The evaluation of Pump Station capacity, as described in the "Pumping Systems" chapter of the most current version of WEF's Manual of Practice FD-4, "Design of Wastewater and Stormwater Pumping Stations."

(C) The evaluation of critical response time, defined as the time interval between activation of the high wet well level alarm and the first SSO, under peak flow conditions.

(D) The evaluation of Pump Station conditions, based upon both physical inspection and recent operating and mechanical failure history during at least the past five years; and

(E) The evaluation of Pump Station design and equipment, including redundancy of pumps and electrical power supply, and other equipment installed, based upon South Carolina Regulation 61-67 (wastewater construction standards). The evaluation of the ability of maintenance personnel to take corrective action within the critical response time calculated for each Pump Station.

c. Information and Management System. The CSAP shall include standard procedures for a CSAP Information Management System and performance goals for each



component of the CSAP set forth in Paragraphs 14.b. (i) through (ix), above.

15. Infrastructure Rehabilitation Program ("IR Program") for the WCTS. Within six (6) months after EPA approval of the CSAP, Columbia shall submit to EPA and DHEC for review, comment, and approval an Infrastructure Rehabilitation Program ("IR Program"). The IR Program shall describe policies and procedures for implementing rehabilitation measures to address I/I, structural issues in the WCTS and the other conditions causing SSOs, with the goal of eliminating future SSOs. The IR Program shall take into account all previous information Columbia has gathered, including any information gathered pursuant to the Work under this Consent Decree. For purposes of developing schedules under Paragraphs 15.a. through 15.e, the IR Program shall include procedures for Columbia to prioritize rehabilitation measures based upon relative likely human health and environmental impact risks, SSO frequencies, and SSO volumes. At minimum, the IR Program shall include the requirements set forth in Paragraphs 15.a. through 15.e. The IR Program may also provide for implementation of line and other small-scale repairs on a "find and fix" basis, where, if feasible, Columbia may implement rehabilitation measures at the time defects are identified.

a. Gravity Sewer Line Rehabilitation. For all Gravity Sewer Lines and related appurtenances, including city-owned laterals, that are identified as in need of rehabilitation under the CSAP, the IR Program shall include procedures for: setting Gravity Sewer Line rehabilitation priorities and schedules; maintaining an ongoing inventory of Gravity Sewer Line rehabilitation projects already performed, scheduled to be performed, and needing to be scheduled and performed, including identification of the rehabilitation techniques used on completed projects; and analyzing the effectiveness of completed rehabilitation projects.

b. Manhole Rehabilitation. For all manholes that are identified as in need of rehabilitation under the CSAP, the IR Program shall include procedures for: setting manhole rehabilitation priorities and schedules; maintaining an ongoing inventory of manhole rehabilitation projects already performed, scheduled to be performed, and needing to be scheduled and performed, including identification of the rehabilitation techniques used on completed projects; and analyzing the effectiveness of completed rehabilitation projects.

c. Pump Station Rehabilitation. For all Pump Stations that are identified as in need of rehabilitation under the CSAP, the IR Program shall include procedures for: setting Pump Station rehabilitation priorities and schedules; maintaining an ongoing inventory of Pump Station rehabilitation projects already performed, scheduled to be performed, and needing to be scheduled and performed, including identification of the rehabilitation techniques used on completed projects; and analyzing the effectiveness of completed rehabilitation projects.

d. Force Main Rehabilitation. For all Force Mains and related appurtenances that are identified as in need of rehabilitation under the CSAP, the IR Program shall include procedures for: setting Force Main rehabilitation priorities and schedules; maintaining an ongoing inventory of Force Main rehabilitation projects already performed, scheduled to be performed, and needing to be scheduled and performed, including identification of the rehabilitation techniques used on completed projects; and analyzing the effectiveness of completed rehabilitation projects.

e. Each component of the IR Program set forth in Paragraphs 15.a. through 15.d. above shall include standard procedures for an IR Program information management

system, standard procedures for inspecting and documenting the quality of new construction and rehabilitated work for warranty and other purposes, and procedures for analysis of the effectiveness of completed rehabilitation.

16. IR Report for the WCTS. Within six (6) months after Columbia has assessed the major components of the WCTS once pursuant to the CSAP, Columbia shall submit to EPA and DHEC for review, comment, and approval an IR Report setting forth a summary of the results of the CSAP of the major components of the WCTS and a description of Columbia's proposed rehabilitation projects, including rehabilitation projects currently underway. The summary of the results of the CSAP shall contain a thorough analysis of historical and current flow monitoring, inspection, rainfall and other data, including data collected during the CSAP.

a. Results of the CSAP. At minimum, the CSAP results summary portion of the IR Report shall include the components set forth in Paragraphs 16.a.i through 16.a.viii. below.

(i). A determination of existing flows for each Subbasin within the WCTS including average and peak daily dry weather flow.

(ii). A determination of the average dry weather Infiltration rate (in gpd/inch diameter-mile).

(iii). A determination of peak wet weather flow and peaking factors (the ratio of peak flow to average dry weather flow).

(iv). Identification of the portions of the WCTS experiencing levels of I/I that cause or contribute to SSOs.

(v). A summary of identified sources of I/I to the WCTS organized by Subbasins, or portions of Subbasins, that indicates the specific types of defects found, and the quantity of each defect type with a given National Association of Sewer System Contractors (NAASCO) defect rating. The summary shall also estimate the total I/I contributions to such Subbasins or portions of Subbasins.

(vi). A summary of flow monitoring activities, that include, at a minimum, a map showing the delineation of the Subbasin, the location and type of each flow meter, problems encountered and deviations from the CSAP, and a description of quality control and quality assurance activities, including the use of scattergraphs, to ensure accurate flow measurement.

(vii). A description of the methods used to estimate I/I, an identification of the locations where the methods were used, and an explanation of the assumptions, rainfall events, and other variables used in estimating I/I.

(viii). A summary of the status of Columbia's development of the hydraulic Model Report required under Paragraph 17.d. of this Consent Decree, including a description of the completed activities and the remaining tasks and activities to be carried out in development of the hydraulic Model Report, and the anticipated dates of completion of such remaining tasks and activities.

b. Rehabilitation of Infrastructure. In accordance with the IR Program, the IR Report shall identify all specific rehabilitation measures and projects, including those currently underway and those additional rehabilitation projects identified through the assessment of the major components of the WCTS pursuant to the CSAP, as needed to address I/I and other conditions causing SSOs. The IR Report will also state the quantity of I/I that Columbia estimates will be removed through each identified rehabilitation project, and describe the methods used to quantify the I/I projected to be removed, including an explanation of the variables used in estimating the I/I projected to be removed. The IR Report shall include a schedule for completion of all identified rehabilitation projects. Based on the results of the initial assessment of major components of the WCTS pursuant to the CSAP, the IR Report shall group the additional rehabilitation projects into three scheduling categories (“Group 1,” “Group 2,” and “Group 3”) according to priority of the projects. The rehabilitation projects in the IR Report shall be prioritized according to their ability to resolve the most serious problems related to capacity overflows and problems related to WCTS segments with the highest defect ratings, as determined by the CSAP’s initial assessment of major components of the entire WCTS. The schedule shall provide for completion of rehabilitation measures identified in the IR Report by the dates listed in Subparagraph b.(i) – (iii) below. Upon approval of the IR Report by EPA and DHEC, Columbia shall complete all rehabilitation projects identified in the IR Report in accordance with the schedule contained therein.

(i). Group 1 rehabilitation projects shall be completed no later than 3 years following EPA and DHEC approval of the IR Report;

(ii). Group 2 rehabilitation projects shall be completed no later than 5 years after EPA and DHEC approval of the IR Report;

(iii). Group 3 rehabilitation projects shall be completed no later than 7 years after EPA and DHEC approval of the IR Report.

c. Supplemental IR Report. Within six (6) months after Columbia has assessed the remainder of the entire WCTS pursuant to the CSAP, as required by Paragraph 14.a, Columbia shall submit to EPA and DHEC for review, comment, and approval a supplemental IR Report which shall update all portions of the IR Report to reflect additional information developed by Columbia through completion of the assessment of the remainder of the entire WCTS. The Supplemental IR Report shall include an updated description of remedial projects that have been completed, including line repairs and small scale repairs completed on a find and fix basis, and shall identify any additional rehabilitation projects identified through ongoing implementation of the CSAP, as needed to address I/I and other conditions causing SSOs. The Supplemental IR Report shall include a schedule for completion of any additional rehabilitation projects no later than five years after EPA/DHEC approval of the Supplemental IR Report. Upon approval of the Supplemental IR Report by EPA and DHEC, Columbia shall complete all additional rehabilitation projects identified in the Supplemental IR Report in accordance with the schedule contained therein.

17. Sewer System Hydraulic Model. Columbia shall develop and maintain a

calibrated hydraulic model of its Sewer System (“the Model”) to establish existing hydraulic conditions and plan for future capacity needs of the Sewer System. The Model shall be developed on a Subbasin basis concurrent with the CSAP schedule for the initial assessment of major components of the WCTS in Paragraph 14 above. The model development schedule will be established based on system attribute data collected as part of the Sewer Mapping Program described in Paragraph 12.f. and flow and rainfall data collected as part of the flow monitoring program described in Paragraph 14.b.(v).

a. Capabilities. At a minimum, the Model shall be capable of:

(i). Accurately predicting the flow rate and hydraulic grade line of wastewater in Force Mains from Major Pump Stations and the Major Gravity Sewer Lines under any historical dry or wet weather condition;

(ii). Accurately predicting the location and severity of SSOs from the WCTS under any historical dry or wet weather condition;

(iii). Fully dynamic temporal analysis, including an accounting of downstream backwater impacts on upstream flows;

(iv). Accurately predicting the impacts of changes to Pump Station capacities on upstream and downstream flow rates and hydraulic grade lines, including hydraulic losses which may result from either full or partial Pump Station failures; and

(v). Generating hydrographs depicting baseline wastewater flow and I/I for the Subbasins for various storm recurrence intervals. The Model shall include methods for

accurately estimating the baseline wastewater flows and I/I components in each Subbasin using quality-controlled flow data obtained for the Sewer System.

b. Implementation. At a minimum, Columbia shall employ the Model to:

(i). Assist with the development and implementation of operation and maintenance procedures that optimize collection and transmission capacity;

(ii). Evaluate the impacts which Infiltration/Inflow rehabilitation projects, proposed system modifications, and upgrades and expansions have on collection and transmission capacity and the performance of Columbia's Sewer System;

(iii). Prioritize the continuing evaluation of the WCTS pursuant to the CSAP in Paragraph 14 above,

(iv). Prioritize rehabilitation projects; and

(v). Implement the Capacity Assurance Program described in Paragraph 12.e., above.

c. Procedures and Protocols. Columbia shall develop and employ written procedures, protocols, and schedules to routinely perform:

(i). Calibrations of the Model to account for age-related and other changes to Sewer System hydraulics, and to obtain and manage updated data from physical field observations and measurements for this purpose;

(ii). Verification of the Model's accuracy and performance; and



(iii). Sensitivity analyses to determine how the Model responds to changes in input parameters and variables.

d. Model Report. Fifteen (15) months after completion of the CSAP for major components of the WCTS described in Paragraph 14 above, Columbia shall submit a report (“Model Report”) to EPA and DHEC which:

(i). Identifies the functional attributes, characteristics, and limitations specific to the Model’s software as compared to other products evaluated by Columbia, and explains how the Model meets the capabilities required in Paragraph 17.a., above;

(ii). Identifies the date that the Model was deemed to be calibrated and functional;

(iii). Identifies all input and output parameters, constants, and assumed values used by the Model;

(iv). Explains the bases for the input parameters used in each Subbasin to characterize baseline wastewater flows and I/I, the quality assurance procedures used in acquiring the input data, and the engineering bases for the selections of constants (e.g., friction factors) and assumed values; and

(v). Provides a brief description of each procedure and protocol developed pursuant to Paragraph 17.c., above, provides the associated schedules, and identifies the individual(s) with their qualifications who are employed to implement the procedures and protocols.

e. Site Audit. Following receipt of the Model Report in Paragraph 17.d., above, EPA and DHEC may conduct compliance audits of the capabilities of the Model, the implementation of the Model, and the use of written procedures and protocols as required by this Paragraph.

## **VI. REVIEW OF DELIVERABLES**

18. Public Review Requirement. Columbia shall post on its website instructions to the public for receiving email notice of future Deliverables. Prior to the submission of each Deliverable to EPA and DHEC, Columbia shall post a copy of the Deliverable on its website and provide notice of such action by email to all parties who have requested such notice. Columbia shall also send to the Reference Librarian at the Richland County Main Library, currently located at 1431 Assembly Street in Columbia, notice of the Deliverable to be submitted, a flyer containing a brief synopsis of the Deliverable, and instructions on how to find the document on Columbia's website. Columbia shall post on its website instructions for submitting comments, and shall allow the public a period of thirty (30) Days to comment on, the following Deliverables: (i) the CSAP required under Paragraph 14; (ii) the IR Program required under Paragraph 15; (iii) the IR Report and Supplemental IR Report required under Paragraph 16; (iv) the CERP required under Paragraph 12.b.; (v) the CAP required under Paragraph 12.e.; (vi) the TSOMP required under Paragraph 12.h.; and (vii) the GSOMP required under Paragraph 12.i. After the 30-day period, Columbia shall consider public comments for a period of up to fifteen (15) Days. Within seven (7) Days after submitting a Deliverable to EPA and DHEC, Columbia shall place a copy of the submitted version of the Deliverable on its website and at the library. Within seven (7) Days after EPA's approval, approval contingent upon conditions, or

modification by EPA, Columbia shall place a copy of such final version of the Deliverable on its website and at the library. Columbia shall maintain all versions of Deliverables on its website, along with all written comments received from the public, EPA, and DHEC, until termination of this Consent Decree.

19. Government Review of Deliverables.

a. Timing of Review of Deliverables. EPA and DHEC agree to use best efforts to expeditiously review and comment on Deliverables. If EPA issues written comments and decisions on the IR Report or Supplemental IR Report more than one-hundred and twenty (120) Days after receipt of such submission, or on any other Deliverable more than sixty (60) Days after receipt of such submission, any subsequent deadline or milestone dependent upon such review and comment shall be extended by the number of days beyond the one-hundred and twenty (120) day or sixty (60) day period that is applicable to the Deliverable, as specified in this Subparagraph a., for EPA's review of Columbia's submittals. Within thirty (30) days after the date that Columbia has reason to believe that a deadline or milestone is extended under this Subparagraph a., Columbia shall inform EPA and DHEC, in writing, of its belief and the amount of time Columbia believes the deadlines or milestones are extended. If EPA disagrees with Columbia's determination that a deadline is dependent upon such comments or decisions, EPA shall inform Columbia in writing. Columbia may dispute EPA's conclusion regarding whether a deadline is dependent upon such comments or decision pursuant to Section XII (Dispute Resolution).

b. EPA Action on Deliverables. After review of any Deliverable that is

required to be submitted pursuant to this Consent Decree, EPA, after consultation with DHEC, shall in writing: (i) approve the submission; (ii) approve the submission upon specified conditions; (iii) approve part of the submission and disapprove the remainder; or (iv) disapprove the submission. If EPA conditionally approves, approves only in part or disapproves entirely a submission, EPA shall provide a written explanation.

20. Approved Deliverables. If a Deliverable is approved by EPA pursuant to Paragraph 19.a., Columbia shall take all actions required by the Deliverable in accordance with the schedules and requirements of the Deliverable as approved. If the Deliverable is conditionally approved or approved only in part, pursuant to Paragraph 19.b.(ii) or 19.b.(iii), Columbia shall, upon written direction from EPA, after consultation with DHEC, take all actions required by the approved plan, report, or other item that EPA, after consultation with DHEC, determines are technically severable from any disapproved portions, subject to Columbia's right to dispute only the specified conditions or the disapproval of portions, under Section XII of this Decree (Dispute Resolution). Following EPA approval of any Deliverable or portion thereof, such Deliverable or portion thereof so approved shall be incorporated into and become enforceable under this Consent Decree.

21. Disapproved Deliverables. If the Deliverable is disapproved in whole or in part pursuant to Paragraph 19.b.(iii) or 19.b.(iv), Columbia shall, within sixty (60) Days or such other time as EPA and Columbia agree to in writing, correct all deficiencies and resubmit to EPA the Deliverable, or disapproved portion thereof, for approval, in accordance with Paragraphs 19 and 20, subject to Columbia's right to dispute the disapproval under Section XII of this Decree (Dispute Resolution). If the resubmission is approved in whole or in part, Columbia shall

proceed in accordance with Paragraph 20.

22. Stipulated Penalties Accruing. Any stipulated penalties applicable to the original Deliverable, as provided in Section X of this Decree, shall accrue during the sixty (60)-Day period or other specified period provided for the correction of deficiencies and resubmittal in Paragraph 21, above, but shall not be payable unless the resubmitted Deliverable is untimely or is disapproved in whole or in part, provided that, if the original submission was so deficient as to constitute a material breach of Columbia's obligations under this Decree, the stipulated penalties applicable to the original submission shall be due and payable notwithstanding any subsequent resubmission.

23. Resubmitted/Revised Deliverables.

a. Resubmitted Deliverable. If a resubmitted Deliverable, or portion thereof, is disapproved in whole or in part, EPA, after consultation with DHEC, may again require Columbia to correct any deficiencies, in accordance with Paragraph 21, or may itself correct any deficiencies, subject to Columbia's right to invoke Dispute Resolution and the right of EPA to seek stipulated penalties as provided in preceding Paragraph 22. Upon EPA's correction of any deficiencies, such resubmitted plan, report, or other item, or portion thereof will be incorporated into and become enforceable under this Consent Decree and shall be implemented by Columbia according to the approved schedule subject to Columbia's right to invoke Dispute Resolution.

b. Revisions to Deliverables. The Parties recognize that, during implementation of this Consent Decree, information may be developed which warrants the

revision of previously submitted and/or approved Deliverables. Columbia may revise previously approved Deliverables only with EPA's prior written approval. For any proposed revised Deliverable, Columbia shall comply with the public notification requirements of Paragraph 18 of this Consent Decree originally applicable to such Deliverable.

24. Certification. Columbia shall, by a person who meets the requirements for reports and other information under 40 CFR § 122.22(b), sign and certify all Deliverables, notices, documents or reports submitted to the United States and State pursuant to this Consent Decree as follows:

*I certify under penalty of law that this document and all attachments were prepared under my direction or supervision in accordance with a system designed to assure that qualified personnel properly gather and evaluate the information submitted. Based on my inquiry of the person or persons who manage the system, or those persons directly responsible for gathering such information, the information submitted is, to the best of my knowledge and belief, true, accurate and complete. I am aware that there are significant penalties for submitting false information, including the possibility of fine and imprisonment for knowing violations.*

## **VII. CIVIL PENALTY**

25. Within thirty (30) Days after the Effective Date of this Consent Decree, Columbia shall pay a total civil penalty in the amount of \$476,400, to be apportioned between the United States and the State as specified in paragraphs 26 and 27, below.

26. Columbia shall pay to the United States \$238,200 of the civil penalty by FedWire

Electronic Funds Transfer (“EFT”) to the U.S. Department of Justice in accordance with written instructions to be provided to Columbia, following lodging of the Consent Decree, by the Financial Litigation Unit of the U.S. Attorney’s Office for the District of South Carolina, 1441 Main Street, Suite 500, Columbia, S.C. 29201 (803) 929-3000. At the time of payment, Columbia shall send a copy of the EFT authorization form and the EFT transaction record, together with a transmittal letter, which shall state that the payment is for the civil penalty owed pursuant to the Consent Decree in United States et al. v. City of Columbia, and shall reference the civil action number and DOJ case number 90-5-1-1-09954, to the United States in accordance with Section XIV of this Decree (Notices); by email to [acctsreceivable.CINWD@epa.gov](mailto:acctsreceivable.CINWD@epa.gov); and by mail to:

EPA Cincinnati Finance Office  
26 Martin Luther King Drive  
Cincinnati, Ohio 45268

27. Columbia shall pay to the State a civil penalty of \$238,200 by check payable to the “South Carolina Department of Health and Environmental Control” within thirty (30) Days after the Effective Date of this Consent Decree. The check shall reference the case name and civil action number herein and shall be sent to:

Glenn Trofatter  
SCDHEC-Bureau of Water  
Water Pollution Control Division  
2600 Bull St.  
Columbia, South Carolina 29201

### **VIII. SUPPLEMENTAL ENVIRONMENTAL PROJECT**

28. Columbia shall implement a Supplemental Environmental Project (SEP), as

described in Appendix I of this Consent Decree in accordance with all provisions of Appendix I of this Consent Decree. The SEP Columbia shall implement, as described in Appendix I, consists of Flooding and Water Quality Improvements in three areas: (i) along the Lower Reach of Rocky Branch, (ii) Smith Branch, and (iii) Gills Creek, with expenditures totaling at least \$1,000,000. The SEP shall be completed within 60 months after entry of this Decree.

29. Columbia is responsible for the satisfactory completion of the SEP in accordance with the requirements of this Decree. Columbia may use contractors or consultants in planning and implementing the SEP.

30. With regard to the SEP, Columbia certifies the truth and accuracy of each of the following:

a. that all cost information provided to EPA in connection with EPA's approval of the SEP is complete and accurate and that Columbia in good faith estimates that the cost to implement the SEP, exclusive of overhead, additional employee time and salary, administrative expenses, legal fees, and contractor oversight, is \$1,000,000;

b. that, as of the date of executing this Decree, Columbia is not required to perform or develop the SEP by any federal, state, or local law or regulation and is not required to perform or develop the SEP by agreement, grant, or as injunctive relief awarded in any other action in any forum;

c. that Columbia is not a party to any open federal financial assistance transaction that is funding or could be used to fund the same activity as the SEP identified



in Appendix I. Columbia further certifies that, to the best of its knowledge and belief after reasonable inquiry, there is no such open federal financial transaction that is funding or could be used to fund the same activity as the SEP, nor has the same activity been described in an unsuccessful federal financial assistance transaction proposal submitted to EPA within two years of the date of this settlement (unless the project was barred from funding as statutorily ineligible). For the purposes of this certification, the term “open federal financial assistance transaction” refers to a grant, cooperative agreement, loan, federally-guaranteed loan guarantee or other mechanism for providing federal financial assistance whose performance period has not yet expired;

d. that the SEP is not a project that Columbia was planning or intending to construct, perform, or implement other than in settlement of the claims resolved in this Decree;

e. that Columbia has not received and will not receive credit for the SEP in any other enforcement action; and

f. that Columbia will not receive any reimbursement for any portion of the SEP from any other person.

31. SEP Completion Report

a. Within 30 days after the deadline for completion of the SEP, Columbia shall submit a SEP Completion Report to the United States, in accordance with Section XVI of this Consent Decree (Notices). The SEP Completion Report shall contain the

following information:

- (i). a detailed description of the SEP as implemented;
- (ii). a description of any problems encountered in completing the SEP and the solutions thereto;
- (iii). an itemized list of all eligible SEP costs expended;
- (iv). certification that the SEP has been fully implemented pursuant to the provisions of this Decree; and
- (v). a description of the environmental and public health benefits resulting from implementation of the SEP (with a quantification of the benefits and pollutant reductions, if appropriate).

32. EPA may, in its sole discretion, require information in addition to that described in the preceding Paragraph, in order to evaluate Columbia's completion reports.

33. After receiving the SEP Completion Report, EPA shall notify Columbia whether or not Columbia has satisfactorily completed the SEP.

34. If Columbia has not completed the SEP in accordance with this Consent Decree, stipulated penalties may be assessed under Section X of this Consent Decree.

35. Disputes concerning the satisfactory performance of the SEP and the amount of eligible SEP costs may be resolved under Section XII of this Decree (Dispute Resolution). No other disputes arising under this Section shall be subject to Dispute Resolution.

36. Each submission required under this Section shall be signed by an official with knowledge of the SEP and shall bear the certification language set forth in Paragraph 24.

37. Any public statement, oral or written, in print, film, or other media, made by Columbia making reference to the SEP under this Decree shall include the following language: “This project was undertaken in connection with the settlement of an enforcement action, United States et al. v. City of Columbia, taken on behalf of the U.S. Environmental Protection Agency and South Carolina Department of Health and Environmental Control, under the Clean Water Act.”

38. For federal income tax purposes, Columbia agrees that it will neither capitalize into inventory or basis nor deduct any costs or expenditures incurred in performing the SEP.

#### **IX. REPORTING REQUIREMENTS**

39. Columbia shall submit the following notices and reports:

a. Quarterly Reports. After the Effective Date of this Consent Decree and until termination of this Decree pursuant to Section XX (Termination), Columbia shall submit to EPA and DHEC quarterly reports by email and by either U.S. Mail or an overnight delivery service. The first such quarterly report shall be submitted to EPA and DHEC no later than thirty (30) days after the second full calendar quarter after the Effective Date of this Consent Decree. Succeeding quarterly reports shall be submitted no later than thirty (30) days after the completion of each succeeding calendar quarter. The quarterly report shall include, at a minimum:

(i). A description of all projects and activities conducted during the

most recently completed calendar quarter to comply with the requirements of this Consent Decree, in Gantt chart or similar format. This description shall include completion percentages of early action capital improvement projects under Paragraph 10, continuing sewer assessments under the CSAP, and the subsequent remedial actions under the IR Report;

(ii). The date, time, location, source, duration, estimated volume, receiving water (if any), cause, and actions taken to repair or otherwise resolve the cause of all SSOs for the most recently completed quarter in a tabulated electronic format;

(iii). The anticipated projects and activities that will be performed in the next quarter to comply with the requirements of this Consent Decree, in Gantt chart or similar format;

(iv). Any additional information that demonstrates that Columbia is implementing the remedial measures required in this Consent Decree; and

(v). The results of water quality monitoring conducted during the previous Calendar Quarter as part of the SEP described in Appendix I to this Consent Decree.

b. Reporting of violations. If Columbia violates any requirement of this Consent Decree or has reason to believe that it is likely to violate any requirement of this Consent Decree in the future, Columbia shall notify the United States and DHEC of such violation and its likely duration within ten days of Columbia first becoming aware of the situation, with an explanation of the violation's likely cause and of the remedial steps taken, and/or to be taken, to prevent or minimize such violation. If the cause of a violation cannot be

fully explained at the time the next quarterly report is due, Columbia shall include a statement to that effect in the report. Columbia shall investigate to determine the cause of the violation and then shall submit an amendment to the report, including a full explanation of the cause of the violation, within thirty (30) days after the quarterly report;

c. Annual Reports. Each year, Columbia shall submit to EPA and DHEC an annual report for the previous calendar year, with the first annual report due on the first March 31<sup>st</sup> which occurs at least six months after entry of this Decree, and subsequent annual reports due each year thereafter by March 31. Each annual report shall include, at minimum:

(i). A summary of the CMOM Programs implemented pursuant to this Consent Decree, including a comparison of actual performance with any performance measures that have been established;

(ii). A summary of each remedial measure and capital project implemented pursuant to this Consent Decree; and

(iii). A trends analysis of the number, volume, duration, and cause of Columbia's SSOs for the previous twenty-four (24) month period.

40. Whenever any violation of this Consent Decree or any other event affecting Columbia's performance under this Decree or its NPDES Permit may pose an immediate threat to the public health or welfare or the environment, Columbia shall notify EPA and DHEC orally or by electronic or facsimile transmission as soon as possible, but no later than 24 hours after Columbia first knew of the violation or event. This procedure is in addition to the requirements

set forth in the preceding Paragraph.

41. All reports shall be submitted to the persons designated in Section XVI of this Consent Decree (Notices).

42. Each report by Columbia under this Section shall be submitted in accordance with the provisions of Paragraph 24 of this Consent Decree. The certification requirement in Paragraph 24 does not apply to emergency or similar notifications where compliance would be impractical.

43. The reporting requirements of this Consent Decree do not relieve Columbia of any reporting obligations required by the CWA or its implementing regulations, SCPCA or its implementing regulations, or by any other federal, state, or local law, regulation, permit, or other requirement.

44. Any information provided pursuant to this Consent Decree may be used by the United States or the State in any proceeding to enforce the provisions of this Consent Decree and as otherwise permitted by law.

#### **X. STIPULATED PENALTIES**

45. Columbia shall be liable for stipulated penalties to the United States and the State for violations of this Consent Decree as specified below, unless excused under Section XI (Force Majeure). A violation includes failing to perform any obligation required by the terms of this Decree, including any work plan or schedule approved under this Decree, according to all applicable requirements of this Decree and within the specified time schedules established by or

approved under this Decree.

46. Late Payment of Civil Penalty. If Columbia fails to pay the civil penalty required to be paid under Section VII of this Decree (Civil Penalty) when due, Columbia shall pay a stipulated penalty of \$1,000 per Day for each Day that the payment is late.

47. Violations. The following stipulated penalties shall accrue for each violation identified below:

a. Unpermitted Discharges. For each Unpermitted Discharge Event occurring on or after two (2) years from the Date of Entry, a stipulated penalty may be assessed as follows:

(i). For each Unpermitted Discharge Event of 5,000 gallons or less, a stipulated penalty may be assessed as follows:

Within two to five years from the Date of Entry, \$250.

More than five years from the Date of Entry, \$1,000.

(ii). For each Unpermitted Discharge Event of more than 5,000 gallons, a stipulated penalty may be assessed as follows:

Within two to five years from the Date of Entry, \$500

More than five years from the Date of Entry, \$2,000

For purposes of Subparagraph 47.a., an Unpermitted Discharge (as defined in Subparagraph 8.uu.) occurring over multiple days at the same location and due to the same

cause(s) is considered one “Unpermitted Discharge Event.” For example, a collapsed pipe that results in an Unpermitted Discharge on multiple days is a single Unpermitted Discharge Event.

b. Failure to Timely Submit Deliverable. For failing to submit any Deliverable, the following stipulated penalties shall accrue:

| <u>Period Beyond Submittal Date</u> | <u>Penalty Per Violation Per Day</u> |
|-------------------------------------|--------------------------------------|
| 1 – 30 days                         | \$500                                |
| more than 30 days                   | \$1,000                              |

c. Failure to Timely Complete Rehabilitation Projects. For each day that Columbia fails to timely complete rehabilitation projects in accordance with the deadlines established in Paragraph 10, Appendices E and F, or Paragraph 16.b. of this Decree, a stipulated penalty shall accrue for each such missed deadline as follows:

| <u>Period Beyond Submittal Date</u> | <u>Penalty Per Violation Per Day</u> |
|-------------------------------------|--------------------------------------|
| 1-14 days                           | \$500                                |
| 15 – 30 days                        | \$1,000                              |
| 31 – 60 days                        | \$1,500                              |
| 61 – 180 days                       | \$2,000                              |
| more than 180 days                  | \$2,500                              |

d. Failure to Timely Implement SEP Milestones. For each Day that Columbia fails to timely implement a SEP milestone set forth in Section VIII or Appendix I, daily stipulated penalties may be assessed as follows:



| <u>Period of Non-compliance</u> | <u>Penalty Per Violation Per Day</u> |
|---------------------------------|--------------------------------------|
| 1 – 60 days                     | \$500                                |
| more than 60 days               | \$1,500                              |

e. Failure to Complete the SEP. For the SEP identified in Section VIII and Appendix I, EPA, after receiving the SEP Completion Report, may notify Columbia that Columbia has failed to satisfactorily complete the SEP in accordance with the terms of this Consent Decree as described in Section VIII and Appendix I (including the required expenditures for the SEP). A stipulated penalty of \$375,000 for the SEP may be assessed, if Columbia does not cure the deficiencies identified in EPA's notice within ninety (90) Days after receiving such notice. Notwithstanding the foregoing, if EPA determines that Columbia has made good faith efforts to satisfactorily complete the SEP and has certified, with supporting documentation, that at least ninety (90) percent of the required amount of money has been spent on the SEP, Columbia shall not be liable for any stipulated penalty.

48. Stipulated penalties under this Section shall begin to accrue on the Day after performance is due or on the Day a violation occurs, whichever is applicable, and shall continue to accrue until performance is satisfactorily completed or until the violation ceases. Stipulated penalties shall accrue simultaneously for separate violations of this Consent Decree.

49. Columbia shall pay stipulated penalties to the United States and the State within thirty (30) Days of a written demand by EPA. Columbia shall pay fifty percent (50%) of the total stipulated penalty amount due to the United States and fifty percent (50%) to the State.

50. The United States may, in the unreviewable exercise of its discretion, reduce or

waive stipulated penalties otherwise due it under this Consent Decree.

51. Stipulated penalties shall continue to accrue as provided in Paragraph 47, during any Dispute Resolution, but need not be paid until the following:

a. If the dispute is resolved by agreement or by a decision of EPA that is not appealed to the Court, Columbia shall pay accrued penalties determined to be owing, together with interest, to the United States and the State within thirty (30) Days of the effective date of the agreement or the receipt of EPA's decision or order.

b. If the dispute is appealed to the Court and the United States prevails in whole or in part, Columbia shall pay all accrued penalties determined by the Court to be owed, together with interest, within sixty (60) Days of receiving the Court's decision or order, except as provided in Subparagraph c., below.

c. If the District Court's decision is appealed, Columbia shall pay all accrued penalties determined to be owed, together with interest, within fifteen (15) Days of receiving the final appellate court decision.

52. Columbia shall pay stipulated penalties owing to the United States in the manner set forth and with the confirmation notices required by Paragraph 26, except that the transmittal letter shall state that the payment is for stipulated penalties and shall state for which violation(s) the penalties are being paid. Columbia shall pay stipulated penalties owing to the State in the manner set forth in Paragraph 27.

53. If Columbia fails to pay stipulated penalties according to the terms of this Consent

Decree, Columbia shall be liable for interest on such penalties, as provided for in 28 U.S.C. § 1961, accruing as of the date payment became due. Nothing in this Paragraph shall be construed to limit the United States or the State from seeking any remedy otherwise provided by law for Columbia's failure to pay any stipulated penalties.

54. Subject to the provisions of Section XIV of this Consent Decree (Effect of Settlement/Reservation of Rights), the stipulated penalties provided for in this Consent Decree shall be in addition to any other rights, remedies, or sanctions available to the United States and the State for Columbia's violation of this Consent Decree or applicable law.

#### **XI. FORCE MAJEURE**

55. "Force majeure," for purposes of this Consent Decree, is defined as any event arising from causes beyond the control of Columbia, of any entity controlled by Columbia, or of Columbia's contractors, that delays or prevents the performance of any obligation under this Consent Decree despite Columbia's best efforts to fulfill the obligation. The requirement that Columbia exercise "best efforts to fulfill the obligation" includes using best efforts to anticipate any potential force majeure event and best efforts to address the effects of any such event (a) as it is occurring and (b) after it has occurred to prevent or minimize any resulting delay to the greatest extent possible. "Force majeure" does not include Columbia's financial inability to perform any obligation under this Consent Decree.

56. If any event occurs or has occurred may delay the performance of any obligation under this Consent Decree, whether or not caused by a force majeure event, Columbia shall provide notice in orally or by electronic or facsimile transmission to EPA and DHEC, within

seventy-two (72) hours of when Columbia first knew or should have known that the event might cause a delay. Within seven (7) days thereafter, Columbia shall provide a written notice to EPA and DHEC an explanation and description of the reasons for the delay; the anticipated duration of the delay; all actions taken or to be taken in an effort to prevent or minimize the delay; a schedule for implementation of any measures to be taken in an effort to prevent or mitigate the delay or the effect of the delay; Columbia's rationale for attributing such delay to a force majeure event if it intends to assert such a claim; and a statement as to whether, in the opinion of Columbia, such event may cause or contribute to an endangerment to public health, welfare or the environment. Columbia shall include with any notice all available documentation supporting the claim that the delay was attributable to a force majeure event. Failure to comply with the above requirements shall preclude Columbia from asserting any claim of force majeure for that event for the period of time of such failure to comply, and for any additional delay caused by such failure. Columbia shall be deemed to know of any circumstance of which Columbia or Columbia's contractors knew or should have known.

57. If EPA, after a reasonable opportunity for review and comment by DHEC, agrees that the delay or anticipated delay is attributable to a force majeure event, the time for performance of the obligations under this Consent Decree that are affected by the force majeure event will be extended by EPA, after a reasonable opportunity for review and comment by DHEC, for such time as is necessary to complete those obligations. An extension of the time for performance of the obligations affected by the force majeure event shall not, of itself, extend the time for performance of any other obligation. EPA will notify Columbia in writing of the length of the extension, if any, for performance of the obligations affected by the force majeure event.

58. If EPA, after a reasonable opportunity for review and comment by DHEC, does not agree that the delay or anticipated delay has been or will be caused by a force majeure event, EPA will notify Columbia in writing of its decision.

59. If Columbia elects to invoke the dispute resolution procedures set forth in Section XII (Dispute Resolution), it shall do so no later than fifteen (15) Days after receipt of EPA's notice. In any such proceeding, Columbia shall have the burden of demonstrating by a preponderance of the evidence that the delay or anticipated delay has been or will be caused by a force majeure event, that the duration of the delay or the extension sought was or will be warranted under the circumstances, that best efforts were exercised to avoid and mitigate the effects of the delay, and that Columbia complied with the requirements of Paragraphs 55 and 56 above. If Columbia carries this burden, the delay at issue shall be deemed not to be a violation by Columbia of the affected obligation of this Consent Decree identified to EPA and the Court.

## **XII. DISPUTE RESOLUTION**

60. Unless otherwise expressly provided for in this Consent Decree, the dispute resolution procedures of this Section shall be the exclusive mechanism to resolve disputes arising under or with respect to this Consent Decree. Columbia's failure to seek resolution of a dispute under this Section shall preclude Columbia from raising any such issue as a defense to an action by the United States or the State to enforce any obligation of Columbia arising under this Decree.

61. Informal Dispute Resolution. Any dispute subject to Dispute Resolution under this Consent Decree shall first be the subject of informal negotiations. The dispute shall be considered to have arisen when Columbia sends the United States a written Notice of Dispute.

Such Notice of Dispute shall state clearly the matter in dispute. The period of informal negotiations shall not exceed twenty (20) Days from the date the dispute arises, unless that period is modified by written agreement between the United States and Columbia. The United States shall consult with the State during the period of informal negotiations. If the United States and Columbia cannot resolve a dispute by informal negotiations, then the position advanced by the United States shall be considered binding unless, within forty-five (45) Days after the conclusion of the informal negotiation period, Columbia invokes formal dispute resolution procedures as set forth below.

62. Formal Dispute Resolution. Columbia shall invoke formal dispute resolution procedures, within the time period provided in the preceding Paragraph, by serving on the United States and the State a written Statement of Position regarding the matter in dispute. The Statement of Position shall include, but need not be limited to, any factual data, analysis, or opinion supporting Columbia's position and any supporting documentation relied upon by Columbia. The United States shall serve its Statement of Position within ninety (90) Days of receipt of Columbia's Statement of Position. The United States Statement of Position shall include, but need not be limited to, any factual data, analysis, or opinion supporting that position and any supporting documentation relied upon by the United States. The United States shall consult with the State during preparation of its Statement of Position. The United States Statement of Position shall be binding on Columbia, unless Columbia files a motion for judicial review of the dispute in accordance with the following Paragraph.

63. Judicial Dispute Resolution. Columbia may seek judicial review of the dispute by filing with the Court and serving on the United States and the State, in accordance with Section

XVI of this Consent Decree (Notices), a motion requesting judicial resolution of the dispute. The motion must be filed within ten (10) Days of receipt of the United States Statement of Position pursuant to the preceding Paragraph. The motion shall contain a written statement of Columbia's position on the matter in dispute, including any supporting factual data, analysis, opinion, or documentation, and shall set forth the relief requested and any schedule within which the dispute must be resolved for orderly implementation of the Consent Decree. The United States shall respond to Columbia's motion within the time period allowed by the Local Rules of this Court. The United States shall consult with the State during preparation of its response. Columbia may file a reply memorandum, to the extent permitted by the Local Rules.

64. Standard of Review.

a. Disputes Concerning Matters Accorded Record Review. Except as otherwise provided in this Consent Decree, in any dispute brought under Paragraphs 62 and 63 pertaining to the adequacy or appropriateness of plans, procedures to implement plans, schedules or any other items requiring approval by EPA under this Consent Decree; the adequacy of the performance of work undertaken pursuant to this Consent Decree; and all other disputes that are accorded review on the administrative record under applicable principles of administrative law, Columbia shall have the burden of demonstrating, based on the administrative record, that the position of the United States is arbitrary and capricious or otherwise not in accordance with law.

b. Other Disputes. Except as otherwise provided in this Consent Decree, in any other dispute brought under Paragraphs 62 and 63, Columbia shall bear the burden of demonstrating that its position complies with this Consent Decree and furthers the objectives of

the Consent Decree.

65. The invocation of dispute resolution procedures under this Section shall not, by itself, extend, postpone, or affect in any way any obligation of Columbia under this Consent Decree, unless and until final resolution of the dispute so provides. Stipulated penalties with respect to the disputed matter shall continue to accrue from the first Day of noncompliance, but payment shall be stayed pending resolution of the dispute as provided in Paragraph 51. If Columbia does not prevail on the disputed issue, stipulated penalties shall be assessed and paid as provided in Section X (Stipulated Penalties).

**XIII. RIGHT OF ENTRY AND INFORMATION COLLECTION AND RETENTION**

66. The United States, the State, and their representatives, including attorneys, contractors, and consultants, shall have the right of entry into any facility covered by this Consent Decree, at all reasonable times, upon presentation of credentials, to:

- a. monitor the progress of activities required under this Consent Decree;
- b. verify any data or information submitted to the United States or the State in accordance with the terms of this Consent Decree;
- c. obtain samples and, upon request, splits of any samples taken by Columbia or its representatives, contractors, or consultants;
- d. obtain documentary evidence, including photographs and similar data; and
- e. assess Columbia's compliance with this Consent Decree.



67. Upon request, Columbia shall provide EPA and DHEC or their authorized representatives splits of any samples taken by Columbia. Upon request, EPA and DHEC shall provide Columbia splits of any samples taken by EPA or DHEC.

68. Until five years after the termination of this Consent Decree, Columbia shall retain, and shall instruct its contractors and agents to preserve, all non-identical copies of all documents, records, or other information (including documents, records, or other information in electronic form) in its or its contractors' or agents' possession or control, or that come into its or its contractors' or agents' possession or control, and that relate in any manner to Columbia's performance of its obligations under this Consent Decree. This information-retention requirement shall apply regardless of any contrary institutional policies or procedures. At any time during this information-retention period, upon request by the United States or the State, Columbia shall provide copies of any documents, records, or other information required to be maintained under this Paragraph.

69. At the conclusion of the information-retention period provided in the preceding Paragraph, Columbia shall notify the United States and the State at least ninety (90) Days prior to the destruction of any documents, records, or other information subject to the requirements of the preceding Paragraph and, upon request by the United States or the State, Columbia shall deliver any such documents, records, or other information to EPA or DHEC. Columbia may assert that certain documents, records, or other information is privileged under the attorney-client privilege or any other privilege recognized by federal law. If Columbia asserts such a privilege, it shall provide the following:

- a. the title of the document, record, or information;
- b. the date of the document, record, or information;
- c. the name and title of each author of the document, record, or information;
- d. the name and title of each addressee and recipient;
- e. a description of the subject of the document, record, or information; and
- f. the privilege asserted by Columbia.

However, no documents, records, or other information created or generated pursuant to the requirements of this Consent Decree shall be withheld on grounds of privilege.

70. Columbia may also assert that information required to be provided under this Section is protected as Confidential Business Information (“CBI”) under 40 C.F.R. Part 2. As to any information that Columbia seeks to protect as CBI, Columbia shall follow the procedures set forth in 40 C.F.R. Part 2.

71. This Consent Decree in no way limits or affects any right of entry and inspection, or any right to obtain information, held by the United States or the State pursuant to applicable federal or state laws, regulations, or permits, nor does it limit or affect any duty or obligation of Columbia to maintain documents, records, or other information imposed by applicable federal or state laws, regulations, or permits.

#### **XIV. EFFECT OF SETTLEMENT/RESERVATION OF RIGHTS**

72. This Consent Decree resolves the civil claims of the United States and the State

for the violations alleged in the Complaint filed in this action through the Date of Lodging of this Consent Decree.

73. The United States and the State reserve all legal and equitable remedies available to enforce the provisions of this Consent Decree, except as expressly stated in Paragraph 72. This Consent Decree shall not be construed to limit the rights of the United States or the State to obtain penalties or injunctive relief under the CWA, SCPCA, or their implementing regulations, or under other federal or state laws, regulations, or permit conditions, except as expressly specified in Paragraph 72. The United States and the State further reserve all legal and equitable remedies to address any imminent and substantial endangerment to the public health or welfare or the environment arising at, or posed by, Columbia's Sewer System, whether related to the violations addressed in this Consent Decree or otherwise.

74. In any subsequent administrative or judicial proceeding initiated by the United States or the State for injunctive relief, civil penalties, other appropriate relief relating to the Sewer System or Columbia's violations, Columbia shall not assert, and may not maintain, any defense or claim based upon the principles of waiver, res judicata, collateral estoppel, issue preclusion, claim preclusion, claim-splitting, or other defenses based upon any contention that the claims raised by the United States or the State in the subsequent proceeding were or should have been brought in the instant case, except with respect to claims that have been specifically resolved pursuant to Paragraph 72 of this Section.

75. This Consent Decree is not a permit, or a modification of any permit, under any federal, State, or local laws or regulations. Columbia is responsible for achieving and

maintaining complete compliance with all applicable federal, State, and local laws, regulations, and permits; and Columbia's compliance with this Consent Decree shall be no defense to any action commenced pursuant to any such laws, regulations, or permits, except as set forth herein. The United States and the State do not, by their consent to the entry of this Consent Decree, warrant or aver in any manner that Columbia's compliance with any aspect of this Consent Decree will result in compliance with provisions of the CWA, SCPCA, or with any other provisions of federal, State, or local laws, regulations, or permits.

76. This Consent Decree does not limit or affect the rights of Columbia or of the United States or the State against any third parties, not party to this Consent Decree, nor does it limit the rights of third parties, not party to this Consent Decree, against Columbia, except as otherwise provided by law.

77. This Consent Decree shall not be construed to create rights in, or grant any cause of action to, any third party not party to this Consent Decree.

#### **XV. COSTS**

78. The Parties shall bear their own costs of this action, including attorneys' fees, except that the United States and the State shall be entitled to collect the costs (including attorneys' fees) incurred in any action necessary to collect any portion of the civil penalty or any stipulated penalties due but not paid by Columbia.

#### **XVI. NOTICES**

79. Unless otherwise specified herein, whenever notifications, submissions, or communications are required by this Consent Decree, they shall be made in writing and

addressed as follows:

To the United States:

Chief, Environmental Enforcement Section  
Environment and Natural Resources Division  
U.S. Department of Justice  
Box 7611 Ben Franklin Station  
Washington, D.C. 20044-7611  
Re: DOJ No. 90-5-1-1-09954

Amy Gillespie  
Environmental Enforcement Section  
U.S. Department of Justice  
Box 7611 Ben Franklin Station  
Washington, D.C. 20044-7611  
Re: DOJ No. 90-5-1-1-09954

and amy.gillespie@usdoj.gov

and

Chief, Water Programs Enforcement Branch  
Water Protection Division  
U.S Environmental Protection Agency, Region 4  
61 Forsyth Street, S.W.  
Atlanta, GA 30303

To EPA

Chief, Water Programs Enforcement Branch  
Water Protection Division  
U.S Environmental Protection Agency, Region 4  
61 Forsyth Street, S.W.  
Atlanta, GA 30303

To the State:

Glenn Trofatter  
SCDHEC-Bureau of Water  
Water Pollution Control Division  
2600 Bull St  
Columbia, SC 29201

And

Roger Hall  
hallrp@dhec.sc.gov

To DHEC:

Glenn Trofatter  
SCDHEC-Bureau of Water  
Water Pollution Control Division  
2600 Bull St  
Columbia, SC 29201

And

Roger Hall  
hallrp@dhec.sc.gov

To Columbia:

City of Columbia  
P.O. Box 147  
Columbia, South Carolina 29217  
Attn: City Manager

City of Columbia  
P.O. Box 667  
Columbia, South Carolina 29202  
Attn: City Attorney

City of Columbia  
P.O. Box 147  
Columbia, South Carolina 29217  
Attn: Chief Financial Officer

City of Columbia  
P.O. Box 147  
Columbia, South Carolina 29217  
Attn: Director Utilities and Engineering

and:

W. Thomas Lavender, Jr.  
Nexsen Pruet, LLC  
1230 Main Street, Suite 700  
Columbia, South Carolina 29201

80. Any Party may, by written notice to the other Parties, change its designated notice recipient or notice address provided above.

81. Notices submitted pursuant to this Section shall be deemed submitted upon mailing, unless otherwise provided in this Consent Decree or by mutual agreement of the Parties in writing.

**XVII. EFFECTIVE DATE**

82. The Effective Date of this Consent Decree shall be the date upon which this Consent Decree is entered by the Court or a motion to enter the Consent Decree is granted, whichever occurs first, as recorded on the Court's docket.

**XVIII. RETENTION OF JURISDICTION**

83. The Court shall retain jurisdiction over this case until termination of this Consent Decree, for the purpose of resolving disputes arising under this Decree or entering orders modifying this Decree, pursuant to Sections XII and XIX, or effectuating or enforcing compliance with the terms of this Decree.

**XIX. MODIFICATION**

84. The terms of this Consent Decree, including any attached appendices, may be modified only by a subsequent written agreement signed by all the Parties. Where the modification constitutes a material change to this Decree, it shall be effective only upon approval

by the Court.

85. Any disputes concerning modification of this Decree shall be resolved pursuant to Section XII of this Decree (Dispute Resolution), provided, however, that, instead of the burden of proof provided by Paragraph 64, the party seeking the modification bears the burden of demonstrating that it is entitled to the requested modification in accordance with Federal Rule of Civil Procedure 60(b).

## **XX. TERMINATION**

86. This Consent Decree may be terminated when the United States determines that Columbia has satisfactorily completed performance of its compliance (Section V) and SEP (Section VIII) obligations required by this Decree, provided that Columbia has fulfilled all other obligations of this Decree, including payment of the civil penalty under Section VII of this Decree and any accrued stipulated penalties as required by Section X of this Decree not waived or reduced by the United States. Columbia may serve upon the United States a Request for Termination, certifying that Columbia has satisfied those requirements, together with all necessary supporting documentation.

87. Following receipt by the United States of Columbia's Request for Termination, the United States and Columbia shall confer informally concerning the Request and any disagreement that they may have as to whether Columbia has satisfactorily complied with the requirements for termination of this Consent Decree. If the United States, after consultation with the State, agrees that the Decree may be terminated, the United States and Columbia shall submit, for the Court's approval, a joint stipulation terminating the Decree.



88. If the United States, after consultation with the State, does not agree that the Decree may be terminated, Columbia may invoke Dispute Resolution under Section XII of this Decree. However, Columbia shall not invoke Dispute Resolution of any dispute regarding termination until one hundred-twenty (120) Days after service of its Request for Termination.

#### **XXI. PUBLIC PARTICIPATION**

89. This Consent Decree shall be lodged with the Court for a period of not less than thirty (30) Days for public notice and comment in accordance with 28 C.F.R. § 50.7. The United States reserves the right to withdraw or withhold its consent if the comments regarding the Consent Decree disclose facts or considerations indicating that the Consent Decree is inappropriate, improper, or inadequate. Columbia and the State each consent to entry of this Consent Decree without further notice and agrees not to withdraw from or oppose entry of this Consent Decree by the Court or to challenge any provision of the Decree, unless the United States has notified the Parties in writing that it no longer supports entry of the Decree.

#### **XXII. SIGNATORIES/SERVICE**

90. Each undersigned representative of Columbia, EPA, and the State, and the Assistant Attorney General for the Environment and Natural Resources Division of the Department of Justice, certifies that he or she is fully authorized to enter into the terms and conditions of this Consent Decree and to execute and legally bind the Party he or she represents to this document.

91. This Consent Decree may be signed in counterparts, and its validity shall not be challenged on that basis. Columbia agrees to accept service of process by mail with respect to all

matters arising under or relating to this Consent Decree and to waive the formal service requirements set forth in Rules 4 and 5 of the Federal Rules of Civil Procedure and any applicable Local Rules of this Court including, but not limited to, service of a summons.

**XXIII. INTEGRATION**

92. This Consent Decree constitutes the final, complete, and exclusive agreement and understanding among the Parties with respect to the settlement embodied in the Decree and supersedes all prior agreements and understandings, whether oral or written, concerning the settlement embodied herein. Other than Deliverables that are subsequently submitted and approved pursuant to this Decree, no other document, nor any representation, inducement, agreement, understanding, or promise, constitutes any part of this Decree or the settlement it represents, nor shall it be used in construing the terms of this Decree.

**XXIV. FINAL JUDGMENT**

93. Upon approval and entry of this Consent Decree by the Court, this Consent Decree shall constitute a final judgment of the Court as to the United States, the State, and Columbia. The Court finds that there is no just reason for delay and therefore enters this judgment as a final judgment under Fed. R. Civ. P. 54 and 58.

**XXV. APPENDICES**

94. The following appendices are attached to and part of this Consent Decree:

“Appendix A” is a Map of the service area for the Sewer System

“Appendix B” is the Lower Richland Sewer Service Agreement

“Appendix C” is the Map of Sewerbasins and Subbasins

“Appendix D” is the Sewer Overflow Response Program, or SORP

“Appendix E” is the Capital Improvement Program for the WWTP

“Appendix F” is the Capital Improvement Program for the WCTS

“Appendix G” is the Fats, Oil and Grease (FOG) Management Program

“Appendix H” is the List of Pump Stations with Capacity Ratings Greater Than  
1000 Gallons Per Minute

~~“Appendix I”~~ is the Description of the Supplemental Environmental Project (SEP)

Revised Appendix I (Doc. # 9-1) *TW*

Dated and entered this 21<sup>st</sup> day of May, 2014.

  
[TERRY L. WOOTEN]  
UNITED STATES DISTRICT JUDGE  
District of South Carolina

WE HEREBY CONSENT to the entry of this Consent Decree, subject to the public notice and comment provisions of 28 C.F.R. § 50.7:

FOR PLAINTIFF UNITED STATES OF AMERICA:



ROBERT G. DREHER  
Acting Assistant Attorney General  
Environment and Natural Resources Division  
United States Department of Justice  
950 Pennsylvania Avenue, NW  
Washington, D.C. 20530

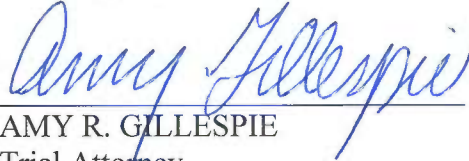

AMY R. GILLESPIE  
Trial Attorney  
Environmental Enforcement Section  
Environment and Natural Resources Division  
United States Department of Justice  
P.O. Box 7611, Ben Franklin Station  
Washington, D.C. 20044-7611  
(202) 616-8754

FOR PLAINTIFF UNITED STATES OF AMERICA (Continued):

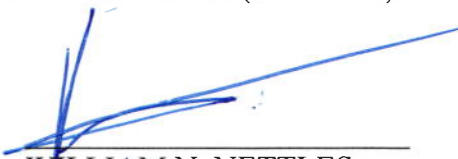

WILLIAM N. NETTLES  
United States Attorney  
District of South Carolina  
First Union Building  
1441 Main Street, Suite 500  
Columbia, South Carolina 29201  
Bill.Nettles@usdoj.gov  
(803) 929-3000





BETH DRAKE  
First Assistant United States Attorney  
District of South Carolina  
First Union Building  
1441 Main Street, Suite 500  
Columbia, South Carolina 29201  
Beth.Drake@usdoj.gov  
(803) 929-3000

WE HEREBY CONSENT to the entry of this Consent Decree, subject to the public notice and comment provisions of 28 C.F.R. § 50.7:

FOR PLAINTIFF UNITED STATES OF AMERICA (Continued):

  
\_\_\_\_\_  
SUSAN SHINKMAN  
Office Director  
Office of Civil Enforcement  
Office of Enforcement and Compliance Assurance  
United States Environmental Protection Agency

  
\_\_\_\_\_  
MARK POLLINS  
Division Director  
Water Enforcement Division  
Office of Civil Enforcement  
Office of Enforcement and Compliance Assurance  
United States Environmental Protection Agency

  
\_\_\_\_\_  
CAROL DEMARCO  
Water Enforcement Division  
Office of Civil Enforcement  
Office of Enforcement and Compliance Assurance  
United States Environmental Protection Agency  
Washington, DC 20460  
Telephone 202-564-2412  
Facsimile 202-564-0024

WE HEREBY CONSENT to the entry of this Consent Decree, subject to the public notice and comment provisions of 28 C.F.R. § 50.7:

FOR PLAINTIFF UNITED STATES OF AMERICA (Continued):

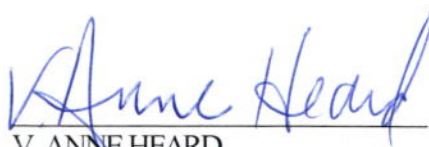

V. ANNE HEARD  
Acting Regional Counsel and Director  
Office of Environmental Accountability  
United States Environmental Protection Agency  
Region 4  
61 Forsyth Street  
Atlanta, GA 30303

Of Counsel:

PAUL SCHWARTZ  
Assistant Regional Counsel  
United States Environmental Protection Agency  
Region 4  
61 Forsyth Street  
Atlanta, GA 30303  
Telephone: (404) 562-9576  
Facsimile: (404) 562-9486

WE HEREBY CONSENT to the entry of this Consent Decree.

FOR THE SOUTH CAROLINA DEPARTMENT OF  
HEALTH AND ENVIRONMENTAL CONTROL:

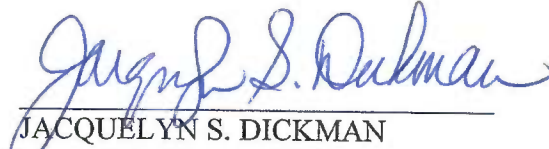

JACQUELYN S. DICKMAN  
Deputy General Counsel  
South Carolina Department of Health  
and Environmental Control



ELIZABETH A. DIECK  
Director of Environmental Affairs  
South Carolina Department of Health  
and Environmental Control

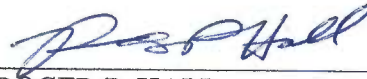

ROGER P. HALL  
Senior Counsel  
South Carolina Department of Health  
and Environmental Control  
2600 Bull Street  
Columbia, SC 29201  
(803) 898-3432



FOR DEFENDANT THE CITY OF COLUMBIA:



TERESA B. WILSON

In her capacity as City Manager

City of Columbia

P.O. Box 147

Columbia, SC 29217

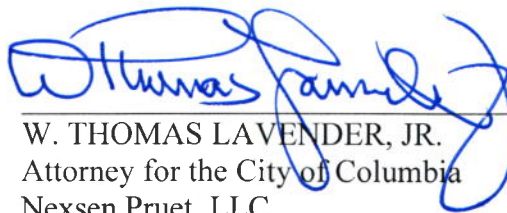

W. THOMAS LAVENDER, JR.

Attorney for the City of Columbia

Nexsen Pruet, LLC

1230 Main Street, Suite 700

Columbia, SC 29201

Federal ID No 2689

## **Appendix A**



# City of Columbia Service Area

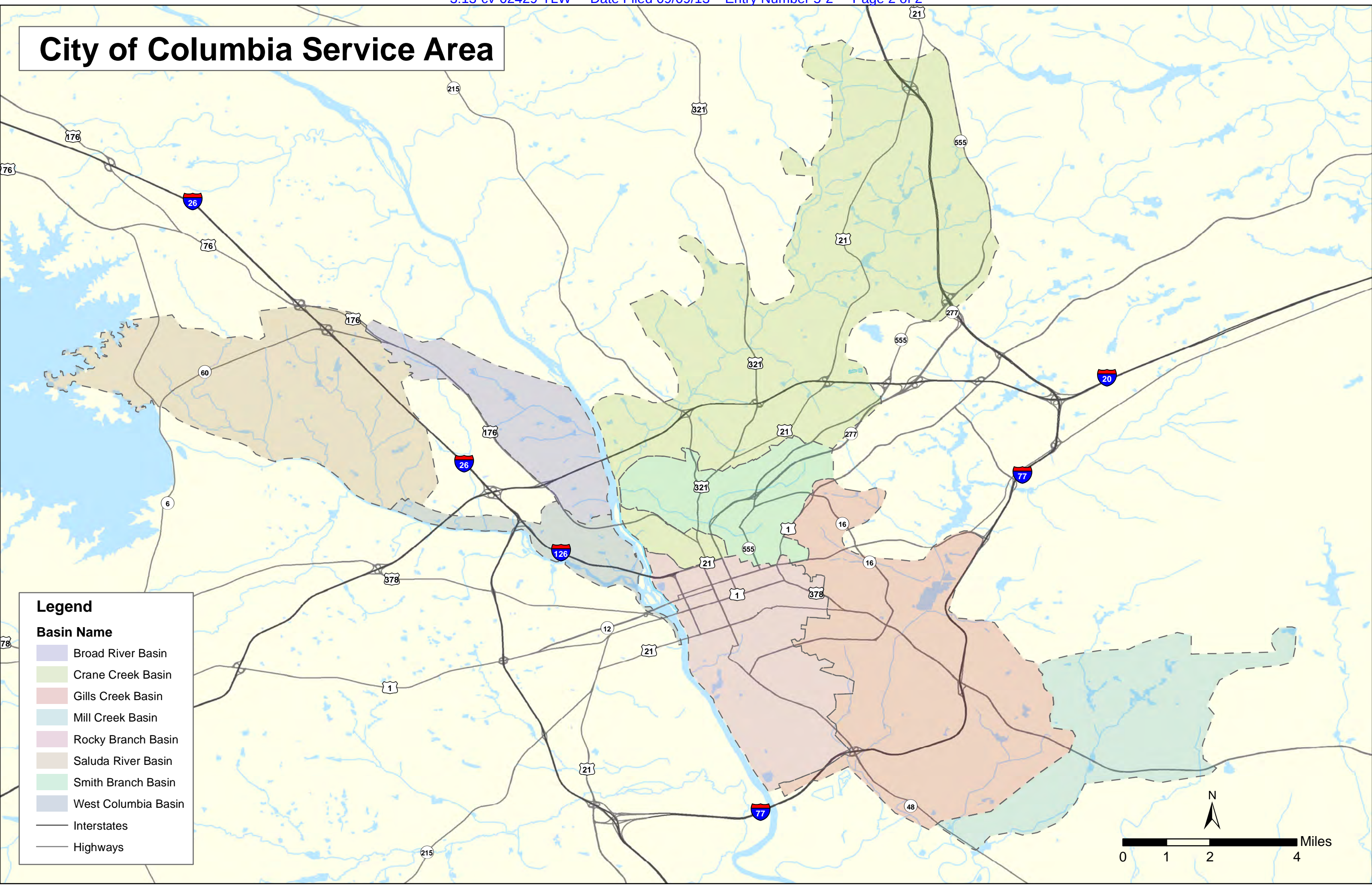

**Legend**

**Basin Name**

- Broad River Basin
- Crane Creek Basin
- Gills Creek Basin
- Mill Creek Basin
- Rocky Branch Basin
- Saluda River Basin
- Smith Branch Basin
- West Columbia Basin

— Interstates  
— Highways

N

0 1 2 4 Miles

## **Appendix B**



**RESOLUTION NO.: R-2010-091**

*Authorizing the City Manager to execute an agreement between the City of Columbia and Richland County for sewer service to certain properties within Richland County's 208 service area*

ORIGINAL  
STAMPED IN REC

BE IT RESOLVED by the Mayor and City Council this 19th day of October, 2010, that the City Manager is authorized to execute the attached Lower Richland Sewer Service Agreement between the City of Columbia and Richland County to provide sewer service to certain properties located within Richland County's 208 service area.

Requested by:

City Manager \_\_\_\_\_

  
\_\_\_\_\_  
Mayor

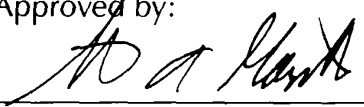
Approved by:  
  
\_\_\_\_\_  
City Manager

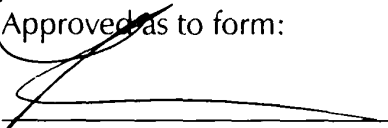
Approved as to form:  
  
\_\_\_\_\_  
City Attorney

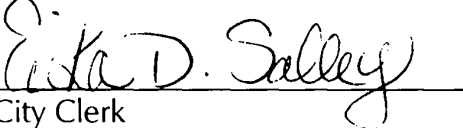
ATTEST:  
  
\_\_\_\_\_  
City Clerk

Introduced: 10/19/2010  
Final Reading: 10/19/2010

2010-0280

**ORIGINAL**  
Stamped in Red

STATE OF SOUTH CAROLINA            )  
  )        LOWER RICHLAND SEWER SERVICE AGREEMENT  
COUNTY OF RICHLAND                )

This Agreement is entered into by Richland County and the City of Columbia for the sole purpose of attempting to make available in the future sewer service to certain properties that are located within Richland County's 208 service area that do not currently have sewer service, as are depicted on Exhibit A, which is attached hereto and incorporated herein by reference (hereinafter "the Properties");

WHEREAS, the City of Columbia is currently providing sewer service to a number of parcels within part of Richland County's 208 service area and has or may have the ability to provide sewer service to additional parcels within Richland County's 208 service area, with such parcels and area being defined hereinafter as "Additional Properties", and as shown within the bounds as depicted on Exhibit A, which is attached hereto and incorporated herein by reference; and,

WHEREAS, Richland County intends to provide sewer service to the Properties and the Additional Properties at some future date by constructing a sewer collection system and treatment plant of sufficient size to serve the Lower Richland area.

For and in consideration of the mutual agreements contained herein, the sufficiency of which is hereby acknowledged, the parties agree as follows:

1. Richland County, subject to approval of the Central Midlands Council of Governments and/or South Carolina Department of Health and Environmental Control, hereinafter "DHEC", if such approvals are required, consents to the City of Columbia providing sewer service to the Properties and the Additional Properties. If such approvals are required and not given, this Agreement shall be null and void.

2. The City of Columbia agrees to transfer ownership of any sewer system serving the Properties and the Additional Properties, in the manner set forth below, to Richland County if Richland County has acquired a Certificate to Operate the intended sewer collection system and treatment plant (hereinafter "Certificate to Operate") from DHEC on or before October 1, 2017, provided however, that if Richland County has not obtained the Certificate to Operate on or before October 1, 2017, the City of Columbia will have no obligation to transfer to Richland County the sewer system serving the Properties or the Additional Properties and this Agreement shall be null and void.

3. If the aforesaid Certificate to Operate is timely acquired, Richland County, in its sole discretion, may, after the aforesaid Certificate to Operate is acquired, negotiate with the City of Columbia to purchase the sewer system serving the Properties and the Additional Properties. Should Richland County decide to purchase any part of the sewer system serving the Properties, if any, or any part of the sewer system serving the Additional Properties, Richland County may be required, at the City of Columbia's option, to purchase the complete and entire sewer system serving both the Properties and the Additional Properties. For the purchase of the sewer system serving the Additional Properties, as such area is depicted on Exhibit A, Richland County agrees to pay the City of Columbia fair market value based upon the cumulative sum of the number of Residential Equivalent Units ("REU") serving the Additional Properties as of the date Richland County notifies the City of Columbia that it will acquire the sewer system serving the Additional Properties multiplied by the value of one REU. The value of one (1) REU will be Eight Hundred and No/100 (\$800.00) Dollars. One (1) REU has a hydraulic loading of 400 gallons per day. The number of REUs serving the Additional Properties will be determined based on the table found at S.C. Regs. Ann. § 61-67, Appx. A (Supp. 2009) (attached hereto and incorporated by reference herein as Exhibit C), and the following formula: (# of units, employees, seats, beds, etc. per parcel) x GPD/400 = REU. Richland County, at its option, may pay the fair market value in five equal annual installments commencing within thirty days of the date Richland County notifies the City of Columbia that it will acquire the sewer system serving the Additional Properties or Richland

County may pay the fair market value as a lump sum within thirty days after notifying the City of Columbia that it will acquire the sewer system serving the Additional Properties or the Properties. For the purchase of the sewer system serving the Properties, Richland County agrees to pay the City of Columbia a one-time fee for the transfer of the sewer system serving the Properties. The one-time fee will be based on an annual average of the utility fees for the preceding two years of the sewer utility fees generated from the Properties and will be due and payable within thirty days after Richland County notifies the City of Columbia that it will acquire the sewer system serving the Properties or the Additional Properties.

4. The City of Columbia, in its sole and exclusive discretion, will determine and approve by City Ordinances the sewer tap rate for any taps sold, sewer service fees or any other fees for sewer service to the Properties. Any of these City Ordinances may be amended from time to time in the sole and exclusive discretion of Columbia City Council. The Properties shall be subject to and fully comply with all applicable rules, regulations and ordinances of the City of Columbia, which may be amended from time to time in the sole and exclusive discretion of Columbia City Council or the City of Columbia. The City of Columbia, through its City Manager or his/her designee, agrees to notify the Richland County Administrator concerning any proposed and/or pending changes to any applicable rules, regulations and ordinances of the City of Columbia concerning sewer tap rates, sewer service fees or any other fees for sewer service.

5. Until such time as the sewer system serving the Properties and the Additional Properties is transferred to Richland County, the City of Columbia will collect and retain all charges for sewer taps and sewer service to the Properties and the Additional Properties.

6. If Richland County has not acquired the Certificate to Operate from DHEC on or before October 1, 2017, Richland County agrees to make a request for and consents to an amendment to the 208 plan by Central Midlands Council of Governments which would add the sewer system serving or to serve the Properties and the Additional Properties to the City of Columbia's 208 sewer service area. The City of Columbia reserves the right to extend the date Richland County must acquire the Certificate to Operate, in its sole and exclusive discretion. The City of Columbia shall grant such an extension, not to exceed two years, if Richland County has completed the design of the aforesaid sewer collection system and treatment plant as is necessary to serve the Properties and the Additional Properties within two (2) years of the date of this Agreement and if Richland County has commenced construction of the aforesaid sewer collection system and treatment plant. Any Agreement to extend the date must be in writing and signed by the parties. Richland County agrees to provide to the City of Columbia semi-annual reports detailing Richland County's progress in meeting the required timelines and deadlines set forth in this Agreement.

7. All costs of design and construction of the sewer system, as well as any upgrades required to the City of Columbia's existing sewer system necessary to provide adequate sewer service to the Properties, in the City of Columbia's sole and exclusive discretion, will be the sole responsibility of the owners of the Properties requesting sewer service and shall be in accordance with all applicable rules, regulations and ordinances of the City of Columbia, which may be amended from time to time in the sole and exclusive discretion of Columbia City Council or the City of Columbia. The design and construction of the sewer system, as well as any upgrades required to the City of Columbia's existing sewer system necessary to provide adequate sewer service to the Properties is subject to the City's approval; however, the City of Columbia will provide and make available to Richland County all design and construction plans approved as a part of this Agreement. The City of Columbia, through its City Manager or his/her designee, agrees to notify the Richland County Administrator concerning any proposed and/or pending changes to any applicable rules, regulations and ordinances of the City of Columbia concerning sewer tap rates, sewer service fees or any other fees for sewer service.

8. Both parties hereby acknowledge that the timelines and deadlines set forth in this Agreement are important to the proper planning and operation of the services outlined herein and, as such, time is of the essence. Failure of either party to meet the required deadlines will be deemed a breach of the Agreement and

is hereby acknowledged by both parties to be material. No extension or waiver of such deadlines shall be enforceable absent written agreement among all parties hereto. In the event either party shall fail to comply with its obligations set forth in the Agreement, and such default shall continue for a period of thirty (30) days after written notice of default has been provided by the other party, then the complaining party shall be entitled to pursue any and all remedies provided under South Carolina law and/or terminate this Agreement.

9. The failure of either party to insist upon the strict performance of any provision of this Agreement shall not be deemed to be a waiver of the right to insist upon strict performance of such provisions or of any other provision of this Agreement at any time. Waiver of any breach of this Agreement by either party shall not constitute waiver of subsequent breach.

10. Written notice to the City shall be made by placing such notice in the United States Mail, Certified, Return Receipt Requested, postage prepaid and addressed to:

City of Columbia  
Attention: City Manager  
Post Office Box 147  
Columbia, SC 29217

With a copy to:

Columbia City Attorney  
Post Office Box 667  
Columbia, SC 29201

Written notice to the County shall be made by placing such notice in the United States Mail, Certified, Return Receipt Requested, postage prepaid and addressed to:

Richland County  
Attention: County Administrator  
Post Office Box 192  
Columbia, SC 29202

11. The transfer of ownership from the City of Columbia to Richland County of the sewer system serving the Properties and the Additional Properties is contingent upon compliance with, and shall be made only in conformity with any applicable bond ordinances and/or any and all applicable bond covenants; which may require, among other things, consent and/or approval from one or more parties not made a party to this Agreement prior to transferring ownership of the sewer system serving the Properties and the Additional Properties. In the event the transfer of ownership of the sewer system serving the Properties and the Additional Properties will violate any applicable bond ordinances and/or any and all applicable bond covenants, the City of Columbia will have no obligation to transfer to Richland County the sewer system serving the Properties or the Additional Properties.

12. This Agreement represents the entire understanding and Agreement between the parties hereto and supersedes any and all prior negotiations, discussions, and Agreements, whether written or oral, between the parties regarding the same. No amendment or modification to this Agreement or any waiver of any provisions hereof shall be effective unless in writing, signed by both parties.

13. This Agreement shall be interpreted pursuant to the laws of the State of South Carolina.

14. If any provision of this Agreement is determined to be void or unenforceable, all other provisions shall remain in full force and effect.



15. The captions and headings throughout this Agreement, if any, are for convenience and reference only, and the words contained therein shall in no way be held or deemed to define, limit, describe, modify, or add to the interpretation, construction, or meaning of any provision of or scope or intent of this Agreement.

16. This Agreement does not and shall not require the City of Columbia to provide sewer service to the Properties or to any other property.

17. This Agreement shall not be binding upon the City until such time as City Council has approved this Agreement and has authorized the City Manager to execute this Agreement. This Agreement is subject to change until such time as City Council has approved this Agreement and has authorized the City Manager to execute this Agreement.

IN WITNESS WHEREOF, the parties have this \_\_\_ day of \_\_\_\_\_, 2010, set their respective hands and seals.

WITNESSES:

Craig A. Quinn  
Eric D. Salley

CITY OF COLUMBIA

BY: Steven A. Gantt  
ITS: City Manager

Deather Brown  
Eric D. Salley

RICHLAND COUNTY

BY: J. Milton Pope  
ITS: County Administrator



**EXHIBIT C****61-67, Appendix A; Unit Contributory Loadings to All Domestic Wastewater Treatment Facilities**

| Type of Establishment                                     | Hydraulic Loading (GPD) |
|---|-------------------------|
| <b>A. Airport:</b>  |                         |
| 1. Per Employee   | 10                      |
| 2. Per Passenger  | 5                       |
| <b>B. Apartments, Condominiums, Patio Homes:</b>          |                         |
| 1. Three (3) Bedrooms (Per Unit)                          | 400                     |
| 2. Two (2) Bedrooms (Per Unit)                            | 300                     |
| 3. One (1) Bedroom (Per Unit)                             | 200                     |
| <b>C. Assembly Halls: (Per Seat)</b>                      | 5                       |
| <b>D. Barber Shop:</b>                                    |                         |
| 1. Per Employee   | 10                      |
| 2. Per Chair  | 100                     |
| <b>E. Bars, Taverns:</b>                                  |                         |
| 1. Per Employee   | 10                      |
| 2. Per Seat, Excluding Restaurant                         | 40                      |
| <b>F. Beauty Shop:</b>                                    |                         |
| 1. Per Employee   | 10                      |
| 2. Per Chair  | 125                     |
| <b>G. Boarding House, Dormitory: (Per Resident)</b>       | 50                      |
| <b>H. Bowling Alley:</b>                                  |                         |
| 1. Per Employee   | 10                      |
| 2. Per Lane, No Restaurant, Bar or Lounge                 | 125                     |
| <b>I. Camps:</b>  |                         |
| 1. Resort, Luxury (Per Person)                            | 100                     |
| 2. Summer (Per Person)                                    | 50                      |
| 3. Day, with Central Bathhouse (Per Person)               | 35                      |
| 4. Travel Trailer (Per Site)                              | 175                     |
| <b>J. Car Wash: (Per Car Washed)</b>                      | 75                      |
| <b>K. Churches: (Per Seat)</b>                            | 3                       |
| <b>L. Clinics, Doctor's Office:</b>                       |                         |
| 1. Per Employee   | 15                      |
| 2. Per Patient  | 5                       |
| <b>M. Country Club, Fitness Center, Spa: (Per Member)</b> | 50                      |
| <b>N. Dentist Office:</b>                                 |                         |
| 1. Per Employee   | 15                      |
| 2. Per Chair  | 8                       |
| 3. Per Suction Unit, Standard Unit                        | 370                     |

|     |  |     |
|-----|--|-----|
| 4.  | Per Suction Unit; Recycling Unit   | 95  |
| 5.  | Per Suction Unit; Air Generated Unit   | 0   |
| O.  | Factories, Industries:   |     |
| 1.  | Per Employee   | 25  |
| 2.  | Per Employee, with Showers   | 35  |
| 3.  | Per Employee, with Kitchen   | 40  |
| 4.  | Per Employee, with Showers and Kitchen   | 45  |
| P.  | Fairgrounds: (Average Attendance, Per Person)  | 5   |
| Q.  | Grocery Stores: (Per one thousand (1,000) Square Feet, No Restaurant)                  | 200 |
| R.  | Hospitals:   |     |
| 1.  | Per Resident Staff   | 100 |
| 2.  | Per Bed  | 200 |
| S.  | Hotels: (Per Bedroom, No Restaurant)   | 100 |
| T.  | Institutions: (Per Resident)   | 100 |
| U.  | Laundries: (Self Service, Per Machine)   | 400 |
| V.  | Marinas: (Per Slip)  | 30  |
| W.  | Mobile Homes: (Per Unit)   | 300 |
| X.  | Motels: (Per Unit, No Restaurant)  | 100 |
| Y.  | Nursing Homes:   |     |
| 1.  | Per Bed  | 100 |
| 2.  | Per Bed, with Laundry  | 150 |
| Z.  | Offices, Small Stores, Business, Administration Buildings: (Per Person, No Restaurant) | 25  |
| AA. | Picnic Parks: (Average Attendance, Per Person)   | 10  |
| BB. | Prison/Jail:   |     |
| 1.  | Per Employee   | 15  |
| 2.  | Per Inmate   | 125 |
| CC. | Residences: (Per House, Unit)  | 400 |
| DD. | Rest Areas, Welcome Centers:   |     |
| 1.  | Per Person   | 5   |
| 2.  | Per Person, with Showers   | 10  |
| EE. | Rest Homes:  |     |
| 1.  | Per Bed  | 100 |
| 2.  | Per Bed, with Laundry  | 150 |
| FF. | Restaurants:   |     |
| 1.  | Fast Food Type, Not Twenty Four (24) Hours (Per Seat)                                  | 40  |
| 2.  | Twenty Four (24) Hour Restaurant (Per Seat)  | 70  |
| 3.  | Drive-In (Per Car Served)  | 40  |
| 4.  | Vending Machine, Walk-up Deli (Per Person)   | 40  |
| GG. | Schools, Day Care:   |     |
| 1.  | Per Person   | 10  |

|     |    |   |     |
|-----|----|---|-----|
|     | 2. | Per Person, with Cafeteria  | 15  |
|     | 3. | Per Person, with Cafeteria, Gym and Showers   | 20  |
| HH. |    | Service Stations:   |     |
|     | 1. | Per Employee  | 10  |
|     | 2. | Per Car Served  | 10  |
|     | 3. | Car Wash (Per Car Washed)   | 75  |
| II. |    | Shopping Centers, Large Department Stores, Malls:<br>(Per one thousand (1,000) Square Feet, No<br>Restaurant) | 200 |
| JJ. |    | Stadiums, Coliseums: (Per Seat, No Restaurant)  | 5   |
| KK. |    | Swimming Pools: (Per Person, with Sewer Facilities<br>and Showers)  | 10  |
| LL. |    | Theaters: Indoor (Per Seat), Drive In (Per Stall)   | 5   |

SC ADC 61-67

**RESOLUTION NO.: R-2010-091**

*Authorizing the City Manager to execute an agreement between the City of Columbia and Richland County for sewer service to certain properties within Richland County's 208 service area*

BE IT RESOLVED by the Mayor and City Council this 19th day of October, 2010, that the City Manager is authorized to execute the attached Lower Richland Sewer Service Agreement between the City of Columbia and Richland County to provide sewer service to certain properties located within Richland County's 208 service area.

Requested by:

City Manager

  
\_\_\_\_\_  
Mayor

Approved by:

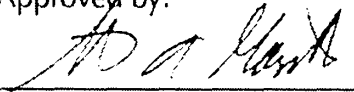
  
\_\_\_\_\_  
City Manager

Approved as to form:

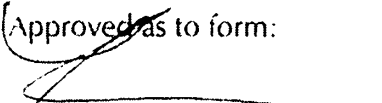
  
\_\_\_\_\_  
City Attorney

ATTEST:

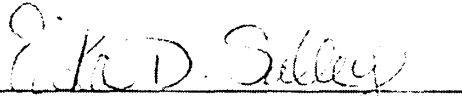
  
\_\_\_\_\_  
City Clerk

Introduced: 10/19/2010  
Final Reading: 10/19/2010

**MEMORANDUM**  
Office of the City Attorney

TO: Erika Salley, City Clerk

FROM:  Shari Lynn Ardis, Legal Admin. Coordinator

DATE: November 8, 2010

RE: RESOLUTION NO.: R-2010-091  
Authorizing the City Manager to execute an agreement between the City of Columbia and Richland County for sewer service to certain properties within Richland County's 208 service area

Please place the attached document in the City's permanent records with the corresponding resolution.

Thank you.

/sla  
Attachment

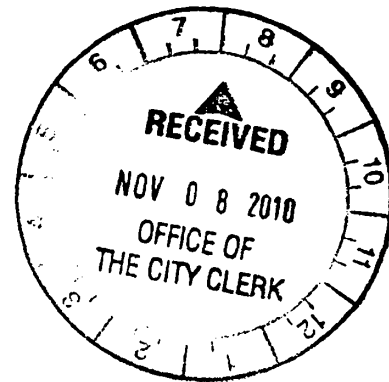

## **Appendix C**



# City of Columbia Sewer Basin and Sub-basin Map

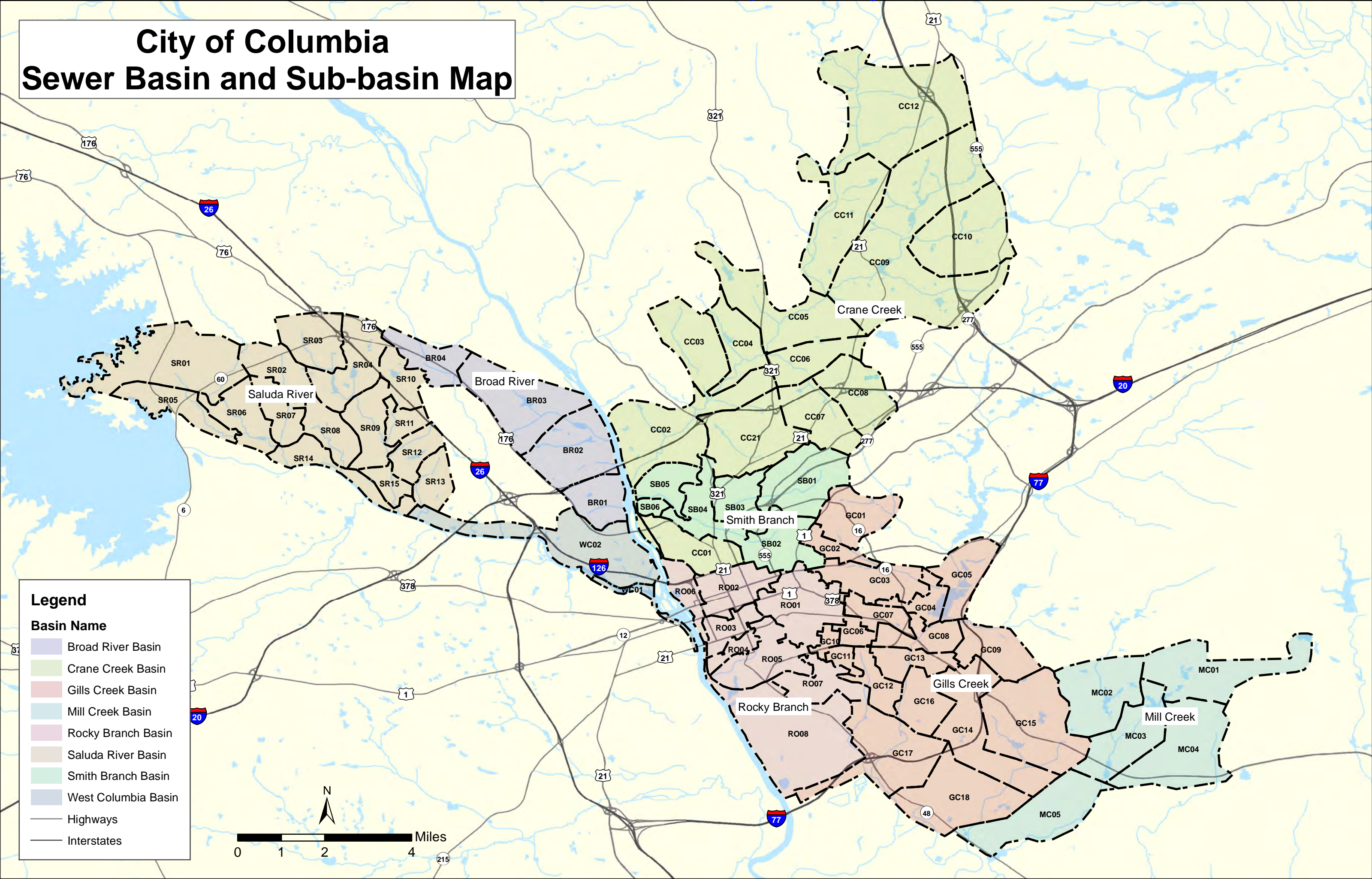

**Legend**

**Basin Name**

- Broad River Basin
- Crane Creek Basin
- Gills Creek Basin
- Mill Creek Basin
- Rocky Branch Basin
- Saluda River Basin
- Smith Branch Basin
- West Columbia Basin

Highways

Interstates

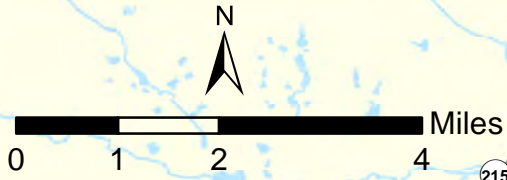



# Appendix D



# **City of Columbia**

## **Sewer Overflow Response Plan (SORP)**

**VERSION 1.1**

**June 2013**



## Table of Contents

|     |  |    |
|-----|--|----|
| 1.0 | Introduction .....   | 3  |
| 1.1 | Purpose.....   | 3  |
| 1.2 | General Background.....  | 3  |
| 1.3 | Objectives.....  | 4  |
| 1.4 | Distribution and Maintenance.....  | 4  |
|     | 1.4.1 Submittal and Availability.....  | 4  |
|     | 1.4.2 Review and Update of Plan.....   | 4  |
|     | 1.4.3 Training.....  | 5  |
| 2.0 | Overflow First Responders.....   | 5  |
| 2.1 | Wastewater Maintenance Division.....   | 5  |
| 2.2 | Metropolitan Wastewater Treatment Plant Division.....                            | 6  |
| 3.0 | Metropolitan Wastewater Treatment Plant Division Overflow Response Procedures... | 6  |
| 3.1 | Detection and Receipt of Information.....  | 6  |
| 3.2 | Dispatch of Appropriate Crews.....   | 7  |
| 3.3 | Overflow Mitigation.....   | 8  |
|     | 3.3.1 Site Assessment.....   | 9  |
|     | 3.3.2 Overflow Correction and Containment.....                                   | 10 |
|     | 3.3.3 Overflow Cleanup.....  | 12 |
| 3.4 | Regulatory Reporting.....  | 13 |
|     | 3.4.1 Data Collection.....   | 13 |
|     | 3.4.2 24-Hour Report.....  | 14 |
|     | 3.4.3 5-Day Written Report.....  | 14 |
|     | 3.4.4 Processing All Sanitary Sewer Overflow Reports.....                        | 15 |
|     | 3.4.5 Fecal Coliform Sampling.....   | 15 |
| 3.5 | Public Notification Procedure.....   | 16 |
|     | 3.5.1 Temporary Signage.....   | 16 |
|     | 3.5.2 Media Notification.....  | 16 |
|     | 3.5.3 Downstream Drinking Water Intakes.....                                     | 17 |
| 4.0 | Wastewater Compliance Section Emergency Response Procedures.....                 | 17 |
|     | 4.1 Public Notice for SSOs Greater than 5,000 Gallons.....                       | 17 |
| 5.0 | Appendices.....  | 18 |
| 5.1 | Appendix A – Dispatcher Plan Protocol.....                                       | 18 |
| 5.2 | Appendix B – 24-Hour Report Checklist.....                                       | 18 |
| 5.3 | Appendix C – 5-Day Written Report [COC SSO Report Form (12/2012)].....           | 20 |
| 5.4 | Appendix D – Discharge Monitoring Report Requirements.....                       | 21 |
| 5.5 | Appendix E – Overflow Calculating.....   | 22 |
| 5.6 | Appendix F – Disinfectant Handling and Responsibilities.....                     | 24 |
| 5.7 | Appendix G – Public Notification Signage.....                                    | 24 |
| 5.8 | Appendix H – Press Release Examples.....   | 28 |
| 5.9 | Appendix I – Stormwater Best Management Practices for WWM and MWWTP.....         | 29 |
| 6.0 | Appendix J – Contact Information.....  | 30 |
| 6.1 | Appendix K – Equipment List.....   | 31 |

## **1.0 INTRODUCTION**

### **1.1 PURPOSE**

The purpose of The City of Columbia's Sewer Overflow Response Plan (SORP) is to facilitate a prompt and appropriate response to any sanitary sewer overflow, release, or diversion of wastewater from the wastewater system. Such events may include, but are not limited to, conditions in the City owned collection system such as blockages and/or flow conditions that have the potential for wastewater backups into buildings, and/or discharges from the collection system designed to carry the wastes from the service area to the treatment plant. Discharges may involve manholes, pump stations, transmission lines, collection lines, or other appurtenances. Sewer back-ups can involve large volumes of wastewater and can pose a substantial threat to the receiving surface waters. Maintenance activities to repair sewer pipes can also create excessive sediment that can impact the storm sewer system. This Plan reflects the procedures established for responding to reports of potential SSOs and confirmed SSOs, and for minimizing the impacts that SSOs and their related activities have on the environment, local waterways and the storm sewer system. Copies of this document will be provided to all persons who are involved in meeting its objectives.

### **1.2 GENERAL BACKGROUND**

The Wastewater Maintenance Division (herein referred to as WWM) and Metro Wastewater Treatment Plant (herein referred to as MWWTP), are responsible for reporting any SSOs that occur. Potential SSOs are defined as possible sanitary sewer overflows. Confirmed SSOs are defined as sanitary sewer overflows where the source has been identified.

The Wastewater Maintenance Division is responsible for reporting SSOs that occur within the sanitary sewer collection system (not including attendant pump stations).

The Metro Wastewater Treatment Plant Division is responsible for reporting SSOs that occur at the MWWTP and wastewater pumping stations.

The Utilities and Engineering Department may also receive SSO reports. The Department will be responsible for directing the SSO report to the appropriate division (WWM or MWWTP).

All SSOs, regardless of amount, will have a City of Columbia (COC) SSO Report Form (04/2013) completed and signed by the Director of Utilities and Engineering or his designee. This report will be signed and forwarded to the South Carolina Department of Health and Environmental Control (SCDHEC) and appropriate City Divisions within 5 calendar days.

Public notice will be made in accordance with Section 4.0 and Appendix H.

The City of Columbia also holds a stormwater NPDES permit issued by SCDHEC. This permit requires the City have controls in place to limit, detect and eliminate sanitary sewer and septage seepage into the MS4. Since the City owns the sewer collection system, SCDHEC also requires the implementation of a Sanitary Sewer Seepage and Infiltration Control Program and Illicit

Discharge Detection and Elimination Program. Specifics for both of these programs can be found in the Stormwater Standard Operating Procedure (SOP) for Element 7: Illicit Discharge Detection and Elimination.

### **1.3 OBJECTIVES**

The procedures set forth herein are intended to be a standardized course of action, with good faith intent, and reflect the following objectives:

1. Protect public health and safety;
2. Maintain a high quality of customer service;
3. Protect private and public property adjacent to the collection and treatment facilities;
4. Protect wastewater treatment and collection system personnel;
5. Protect the collection system, wastewater pumping stations, wastewater treatment facilities, and all appurtenances;
6. Minimize adverse water quality, stormwater, and other environmental impacts;
7. Comply with all local, state, and federal rules and regulations;
8. Avoid NPDES permit violations; and,
9. Minimize liability.

### **1.4 DISTRIBUTION AND MAINTENANCE**

#### **1.4.1 SUBMITTAL AND AVAILABILTY**

The Director of Utilities & Engineering or his/her designee will distribute copies of the Plan and any amendments here to the following:

1. City Manager
2. City Engineer
3. Superintendent of Water Plants
4. Wastewater Maintenance Superintendent
5. Wastewater Plant Superintendent
6. Director of Utilities and Engineering
7. Wastewater Engineer

It shall be the responsibility of the appropriate supervisor to ensure that any other personnel who may become involved in responding to a potential SSO have a copy of the Plan, have access, and are familiar with its contents. This includes foremen and crews doing the actual work in the field. An electronic copy of the Plan may be made available to others upon request.

#### **1.4.2 REVIEW AND UPDATE OF PLAN**

This Plan will be reviewed and amended as appropriate. The WWM Superintendent or MWWTP Superintendent or his/her designee shall conduct an annual review of the Plan and provide any recommended updates to the Director of Utilities and Engineering. The Director of Utilities and Engineering will update the Plan as necessary to reflect updates provided by the

WWM Superintendent or MWWTP Superintendent or his/her designee. The Director of Utilities and Engineering or his/her designee will provide an updated copy of the Plan to staff noted above in section 1.4.1.

### **1.4.3 TRAINING**

The WWM Superintendent or MWWTP Superintendent or his/her designee will train appropriate personnel on the use of the Plan and any updates thereto. Continuing education training will be repeated at least annually, when new employees are hired, or whenever changes are made to the Plan. Training will also cover stormwater protection techniques and Best Management Practices (BMPs) use/ selection for each crew. This training may be combined with other staff training initiatives.

This Plan will be a living document and regularly updated to ensure a timely and appropriate response to all wastewater related sanitary sewer overflows. The Plan will be used as the training guide and the training will focus on:

1. SSO Emergency Response Plan Procedures;
2. SSO Emergency Response Plan Objectives;
3. Call Taking and Dispatch of Appropriate Crews;
4. Site Assessment, SSO Correction, Containment and Clean Up;
5. Public Advisory Procedures, Temporary Signage, and Media Notification;
6. Downstream Drinking Water Sources Notification;
7. Regulatory Agency Notification;
8. Safety Procedures; and
9. Documentation, Data Collection, Volume Calculations and Record Keeping.

This Plan is intended to be a short-term, proactive approach to managing potential or confirmed SSOs and their immediate effects. The Plan is an integral component of a broader watershed approach to controlling SSOs.

## **2.0 OVERFLOW FIRST RESPONDERS**

### **2.1 WASTEWATER MAINTENANCE (WWM) DIVISION**

The City currently owns, operates, and maintains, approximately 1,200 miles of sanitary sewer pipes that are the responsibility of its Wastewater Maintenance Division. (The City's wastewater pump stations and treatment plant fall under the responsibility of the MWWTP. Objectives of the Wastewater Maintenance Division include:

1. Quality service to customers;
2. Management of infrastructure assets, including sewage collection;
3. Utilization of sound business practices; and
4. Regulatory compliance.

The City will operate and maintain all components of the wastewater collection system in a fashion that will minimize the potential of SSOs. The City places emphasis on programs and

training of qualified personnel who are expected to be professional and proactive. Despite best efforts, and due to unforeseeable events such as vandalism and catastrophic weather conditions, all SSOs may not be eliminated. The procedures contained in this Section will be implemented by staff of the Wastewater Maintenance Division when SSOs occur.

## **2.2 METROPOLITAN WASTEWATER TREATMENT PLANT (WWTP) DIVISION**

The City currently owns, operates, and maintains, a 60 MGD wastewater treatment plant and 67 sanitary sewer pump stations that are the responsibility of its MWWTP maintenance and lift station maintenance staff. The City's sanitary sewer collection system and piping do not fall under the responsibility of the MWWTP. Objectives of the MWWTP include:

1. Quality service to customers;
2. Management of infrastructure assets, including wastewater treatment and pump stations;
3. Utilization of sound business practices;
4. Minimize adverse water quality, stormwater, and other environmental impacts; and
5. Regulatory compliance.

The City will operate and maintain all components of the wastewater treatment plant and sanitary sewer pump stations in a fashion that will minimize the potential of SSOs. The City places emphasis on programs and training of qualified personnel who are expected to be professional and proactive. Despite best efforts, and due to unforeseeable events such as vandalism and catastrophic weather conditions, all SSOs may not be eliminated. The procedures contained in this Section will be implemented by staff of the MWWTP when SSOs occur.

Additionally, The City of Columbia also holds a stormwater NPDES permit issued by SCDHEC. This permit requires the City have controls in place to limit, detect and eliminate sanitary sewer and septage seepage into the MS4. Since the City owns the sewer collection system, SCDHEC also requires the implementation of a Sanitary Sewer Seepage and Infiltration Control Program and Illicit Discharge Detection and Elimination Program. Specifics for both of these programs can be found in the Stormwater Standard Operating Procedure (SOP) for Element 7: Illicit Discharge Detection and Elimination.

## **3.0 OVERFLOW EMERGENCY RESPONSE PLAN**

### **3.1 DETECTION AND RECEIPT OF INFORMATION**

Potential SSOs and/or Potential Building Backups are generally reported and treated in the same manner as outlined herein.

1. These may be reported and/or detected by the general public, and/or the SCDHEC by calling the Customer Care Center 803-545-3300. The Customer Care Center has personnel available to answer the phone at 803-545-3300, 24 hours per day, 7 days per week. The call taker will seek to get enough information from the caller to determine if a potential SSO involves the storm drain system, drinking water system or



wastewater system. Additionally, reports may be made to the WWM Division and MWWTP telephone numbers are available in the blue pages of the Columbia Area AT&T phone book under "Sewer Maintenance" and "Sewage Treatment Plant." Persons calling these Divisions can report a potential SSO 24 hours per day, 7 days a week.

2. WWM personnel are instructed to report all potential SSOs immediately to the WWM Superintendent or his/her designee by calling 803-600-5619.
3. MWWTP personnel are instructed to report all potential SSOs immediately to the MWWTP Superintendent or his/her designee by calling 803-413-8376.

All call takers will record all relevant information known by the caller regarding the potential SSO, including:

1. Time and date the call was received and the person who received the call;
2. Specific location of the potential SSO;
3. Time the potential SSO was noticed by the caller;
4. Caller's name and phone number(s), and how best to contact for follow up;
5. Information concerning specifics supplied by the caller (i.e., odor, duration, in street, back or front of property);
6. Whether or not a potential SSO has reached or is flowing towards a creek, stream or river, a park, playground, school yard, or other public use location; and
7. Other relevant information that will enable the responding investigator and crews, to quickly locate, assess and alleviate the potential SSO.

### **3.2 DISPATCH OF APPROPRIATE CREWS**

The purpose of immediate response to a potential SSO is to identify and correct any problems that could cause or has caused an SSO. If more than one potential SSO occurs at or near the same time period, different crews will be sent to address the different potential SSOs, when possible. If this is not possible, the potential SSOs will be prioritized by an appropriate Division Superintendent or his/her designee in order of greatest threat to public health, surface waters and property. Water quality monitoring for overflows will be conducted as directed by SCDHEC. In such case, SCDHEC will determine the parameters to sample for and at what locations.

Depending on the nature of the spill, the City may take samples concurrently with SCDHEC. Phone calls or other correspondence related to potential SSOs are generally directed to one of the Wastewater Divisions. During normal business hours, the Office Assistant who acts as Dispatcher may receive calls as outlined hereinabove and in Appendix A. Calls are also received at the MWWTP. Operators there are trained to relay potential SSOs to the appropriate crews (WWM or MWWTP personnel).

A City representative or an automated response system will dispatch calls that are received after normal business hours, holidays and weekends as outlined hereinabove and in Appendix A. The on-duty Foreman has a complete list of on-call personnel, including WWM or MWWTP personnel, and their contact phone numbers.

On-call personnel for both WWM and MWWTP rotate weekly (WWM) and every twelve hour shift (MWWTP). A City issued cell phone rotates with the person who is on-call. Calls are routed as follows for investigation:

1. Potential SSOs that are based in the collection system are routed to the WWM Superintendent or his/her designee.
2. Potential SSOs that are based in Wastewater pump stations and/or the treatment plant are routed to the MWWTP Superintendent or his/her designee.

During wet weather events, an appropriate Division Superintendent will have personnel inspect locations that are known to be recurring overflow locations. A list/map of these locations is maintained and updated on GIS. A copy of this map is located in a central area so personnel know where to respond during a rain event.

During pump station failures, an appropriate Superintendent will have personnel inspect the locations prone to overflow during these failures. A list/map of these locations will be developed as part of the Contingency and Emergency Response Plan (CERP). Once developed, the list/map will be maintained and updated on GIS. A copy of this map will also be located in a central area so personnel will know where to respond during a pump station failure.

### **3.3 OVERFLOW MITIGATION**

The City will reduce the negative impact on the environment and hazards to public health by employing all reasonable containment activities during discharge events. Under most circumstances, both Wastewater Divisions have personnel and equipment that will be able to correct, contain, and clean up wastewater related SSOs. A list of equipment is updated by and maintained within the City's Accounting Department.

A situation may arise that will require the support of an outside contractor. The list of emergency contractors is maintained and updated within the Engineering Division of the Utilities and Engineering Department. Examples may include, repair to sewer pipe in remote areas, creek crossings, or large diameter pipe buried deeply where extensive shoring may be required to resolve the SSO. The City solicits bids on an emergency basis in the event that a contractor is needed. In these cases, interim measures are taken to contain the SSO and prevent any additional harm to the environment, private property, public health, etc. Contractors are responsible for the same level of environmental stewardship as City crews, and requirements for appropriate BMPs (such as inlet protection, debris cleanup, etc.) will be provided to contractors before any work begins.

### 3.3.1 SITE ASSESSMENT

All Wastewater personnel responding to a potential SSO will adhere to the following guidelines:

1. It is the responsibility of the first responder who arrives at the site of a potential SSO to protect the health and safety of the public.
2. If the first responder is unable to address the problem, then the appropriate supervisor will be notified immediately. The supervisor will employ appropriate measures (i.e. CCTV, smoke testing, etc.) to determine cause of SSO.
3. The health and safety of the public and City personnel are of primary concern. Responding crew members will contact their supervisor whenever a suspicious substance (i.e., oil sheen, foamy residue) is found on the ground surface, within surface waters or ponded areas, or upon detection of a suspicious odor (i.e., gasoline, chemical), not common to the sewer system. City staff (WWM, MWWTP, U&E) follow Job Hazard Assessment, are trained in safe handling of sanitary sewer overflows, and follow universal precautions for raw sewage and blood borne pathogens.
4. The proper regulatory agency will be notified if the first responder notices any overflows (i.e. non-rainwater discharges) entering a body of water or a storm drain.
5. Estimate the overflow in accordance with the guidelines in Section 5, Appendix E herein. Notify Wastewater Compliance immediately for public notification guidance when:
  - a. Calculations determine the overflow to be 5000 gallons or more, or when;
  - b. Overflow directly enters a body of water and calculation shows greater than 1000 gallons.
6. Due to the emergency nature of most wastewater activities, the Stormwater Section staff understands that stopping or unstopping the flow is the major concern of the Wastewater department. As early as is feasibly possible (but always before any digging activity), a member of the Wastewater crew will deploy inlet protection devices for the immediate area and out through a 50 foot radius. Any storm drains, conveyance channels, or sensitive areas (wetlands, adjacent waters, etc.) will be protected, when feasible, with sandbags, gravel bags, sediment tubes, or a combination of the three BMPs. All applicable crews will have this equipment. These inlet protection measures should stay in place until the maintenance activity has been completed, thus reducing the sediment and pollutant impact. In some cases, the bags or tubes can be rinsed out over a vegetated area and reused.
7. The Fire Department Hazardous Material Response Team (HAZ-MAT) will be notified if hazardous material is suspected.
8. Associated personnel will assist, as necessary, to insure that all potential SSOs are addressed in a timely manner. On-call personnel, Foremen and MWWTP/WWM personnel will communicate and coordinate activities and transfer pertinent information

to the next shift at shift change, including and details of the problem and observations described by the person who reported the problem.

### **3.3.2 OVERFLOW CORRECTION AND CONTAINMENT**

Containing spills is the concept of establishing a physical barrier to control the further dispersal of sewage, thus reducing the impact on downstream areas such as private property and streams. Containment procedures will vary on a case-by-case situation. Such measures are specifically designed to ensure that the proposed plan of action will meet the goals of the SORP.

Upon arrival at a potential SSO, (i.e., sewer line blockage, sewer line break, pump station malfunction) the responding personnel will:

1. Request assistance as needed to determine the cause and contain the SSO;
2. Immediately determine where the SSO has occurred and determine the immediate destination of the SSO (i.e., storm drain, surface water, ground surface, and so on);
3. Immediately secure the work area and request personnel, materials, and equipment as required to expedite containment of the SSO;
  - For pump station-specific emergency procedures refer to the CERP.
4. Determine Whether Flow Diversion Techniques Are Practicable.  
When possible, flow diversion techniques provide an effective means of conveying the overflow back into the sewer system. This procedure reduces additional potential impact on the immediate area and the possible impact downstream. The flow diversion techniques employed by the City when practicable include, but are not limited to, the following:
  - **By-passing measures**  
Portable by-pass pumps can be used in certain situations to collect overflowed sewage from the environment and convey it back into the sanitary sewer system beyond the disruption of service. This method is most effective in bypassing a single identified problem area when the overflow can be directed to the next downstream manhole. It is not appropriate in wet weather overflows. This type of equipment can be used in conjunction with other containment measures or may be used independently. Additionally, the City maintains a list of qualified contractors capable of providing emergency by-pass pumping as may be required.
  - **Vactor/Combination cleaner/flusher procedures**  
Combination cleaner/flusher equipment provides an additional resource for collecting overflowed sewage and conveying it back into the sanitary sewer system beyond the disruption of service. This equipment can be used in certain situations in conjunction with other containment measures or may be used independently. Like portable by-pass pumps, this equipment may not be effective in wet weather situations.

5. Mitigation/Remediation Solutions.

The timely use of flow restrictions is the most effective instrument to reduce additional negative impact on the environment. Also, this phase of field activities may enable restoration of service to City wastewater customers.

The type of mitigation and remediation will vary depending on the cause of the SSO. Wet weather SSOs are usually caused by inflow and infiltration (I/I), not by blockages or other problems in the system. Mitigation of wet weather overflows may not be possible until the overflow subsides, but when it does, The City will implement all necessary steps to clean up and disinfect the overflow site.

Dry weather events may be addressed using several methods. The field professionals should identify the most effective method or combination of methods to return service to the system. Field crews should use television inspection to determine the most effective way to resolve any service disruption. CCTV inspection will identify the cause and location of the blockage and the necessary techniques needed to eliminate it.

6. Deploy inlet protection for the immediate area and out through a 50 foot radius. Any storm drains, conveyance channels or sensitive areas (wetlands, adjacent waters, etc.) will be protected with sandbags, gravel bags, sediment tubes, or a combination of the three BMPs;
7. Control pedestrian and vehicular traffic, as needed, using flagmen, barricades, warning tape, fencing, signage, etc.; and
8. Universal precautions shall be used during corrective and containment activities.

The primary objective of the first responder(s) is to correct the immediate cause of all SSOs. Personnel on the scene will also determine if the SSO is going into "Waters of the United States" (See Section 5.2 APPENDIX B Number 4). If private property is involved, the responding personnel will use discretion in providing assistance to a private property owner/occupant who may have sustained property damage. Generally, a responding crew should not enter private property for the purpose of assessing damage unless directed otherwise by a Foreman or Supervisor. If the SSO has entered "Waters of the State", the first responder will notify the proper regulatory agency.

An appropriate Division Superintendent or his/her designee will assist the first responder and visit the site of the SSO as needed to ensure that all of the provisions of this Plan and other directives are met. Should the cause of the SSO not be related to infrastructure owned by the City (i.e., an overflowing private sanitary sewer), but there is imminent danger to public health, public or private property or to "Waters of the United States", then prudent emergency action shall be taken until the responsible party assumes responsibility.

An appropriate Division Superintendent or his/her designee will notify SCDHEC of all identified SSOs not related to infrastructure owned by the City.

SSOs from private laterals, into basements, etc. which are alleged to be the result of problems in the wastewater collection system will be addressed by WWM Inflow & Infiltration (I & I) personnel on a case by case basis.

SSOs are tracked by the Stormwater Section on a GIS layer to identify potential long-term water quality impacts.

### **3.3.3 OVERFLOW CLEAN UP**

For all SSOs, the clean-up methods used will strive to meet the criteria established in Section 1.3 – Objectives. General guidelines for clean-up include:

1. The SSO area will be secured to prevent contact by the public during the cleaning process. Signage and notice requirements, as deemed necessary to prevent such contact, will be implemented as provided in Section 3.5 below;
2. All storm drains or storm sewer conveyance structures within a 50 ft. radius will be bermed off using sand or gravel bags, sediment tubes, or a combination of the three items. These BMPs are put into place to prevent sediment and other solids from entering the storm sewer system;
3. Removal of all readily identifiable residues (i.e., fecal matter, sludge, rags, papers, or plastics);
4. Cleanup activities will utilize universal precautions;
5. Where practical in locations where flush water will not flow to "Waters of the United States", the SSO area will be flushed with wash down water. If possible, the wash down water will be contained and properly disposed of;
6. If the SSO is to dry land only and flushing causes the SSO and/or flush water to reach "Waters of the United States" the incident will be reported as a SSO to "Waters of the United States";
7. Solids and other debris will be flushed, swept, raked, picked up and transported to proper disposal sites;
8. Standing water that has collected as a result of the SSO will be pumped and returned to the sewage system, if possible. Solids and associated wastewater debris remaining after the area has been pumped will be flushed, raked, picked up, and removed from the site and properly disposed of;

9. Contaminated soil will be treated with lime in accordance with SCDHEC regulations, product label and Material Safety Data Sheet;
10. Any sediment or soil that remains on an impervious surface (street, parking lot, etc.) must be removed to the maximum extent practical. Crews should use backhoes (for large amounts) and shovels and brooms to remove excess sediment that could wash into storm drains;
11. After all digging and cleanup activities have finished, the inlet protection BMPs may be removed. If planning to re-use the bags or sediment tubes, they should be rinsed out over a pervious surface or vegetated area. Never rinse them out over a storm drain, water body or ditch, or impervious surface (like the street). If bags or tubes have been saturated with sanitary debris or solids, they should be disposed of properly to the sanitary landfill;
12. When activities are complete, inspect the flow path of the discharge. Identify any areas that may have experienced soil erosion and need repair. Use erosion control blankets, mulch or geo-fabric with hay matting (which can include seeds) to stabilize soil erosion. Always make every attempt to re-establish vegetation on the impacted area, and if necessary continue inspections until the area has stabilized. Contact the Stormwater Section (803-545-3304) with any questions or help with ongoing inspections or stabilization issues; and
13. Do not hose down the area to remove sediment (unless it is necessary for traffic safety).
14. Wastewater staff will respond to Building Backups to determine the cause of the backup. If the backup is determined to be caused by the City's sewer system, the customer will be referred to the insurance claims adjuster. The City has open purchase orders with approved private cleanup companies that can begin to clean up the facility/home immediately while the claim is being processed.

### **3.4 REGULATORY REPORTING**

#### **3.4.1 DATA COLLECTION**

If a potential SSO is confirmed to be an SSO:

1. The individual responding to the SSO will report findings to an appropriate Division Superintendent or his/her designee.
2. An appropriate Division Superintendent or his/her designee will insure the procedures within Section 5 are completed.
3. An appropriate Division Superintendent or his/her designee will document immediate actions taken to mitigate the SSO and the steps taken to prevent recurrence. These



notes will become a part of the final 5 Day Written Report filed for the record and used for notification purposes.

4. The Department of Utilities and Engineering will provide the Stormwater Section with an annual report that tracks relevant activities including but not limited to: volume of wastewater captured, amount of solids recovered, miles of pipe cleaned, number of spills, employee training, etc.

If a potential SSO is reported and no SSO is confirmed, an appropriate Division Superintendent or his/her designee will document and have a report on file of the incident.

### **3.4.2 24-HOUR REPORT**

An appropriate Division Superintendent or his/her designee will contact SCDHEC Region 3 – Columbia EQC Office within 24 hours of confirming an SSO. This contact will be by telephone at 803-896-0620 during normal business hours and after-hours reporting shall be made to SCDHEC's 24-hour Emergency Response number at 803-253-6488.

The 24 Hour Report will include, at a minimum, the following information:

1. Identification of the utility name, person reporting the SSO, and a contact number;
2. Date and start time of the SSO;
3. Location of the SSO by street address or other appropriate method; and
4. Whether the confirmed SSO is reaching "Waters of the United States."

### **3.4.3 5-DAY WRITTEN REPORT**

In addition to the 24 Hour Report, an appropriate Division Assistant Superintendent or his/her designee will prepare and submit a written report of the SSO to the Wastewater Compliance Section for processing and submittal, in accordance with procedures outlined in Section 3.4.4, to SCDHEC. This report will be submitted to SCDHEC within five (5) days of the confirmation of the SSO (5 Day Written Report). COC SSO Report Form (01/2013) is used for the 5 Day Written Report and will include, at minimum, the following information:

1. Duration and volume (estimate if unknown) of the SSO;
2. Location of the SSO by street address or other appropriate method;
3. Cause of the SSO;
4. Description of the source, e.g., manhole cover, pump station;
5. Exact dates and times of the SSO event, i.e., start and stop dates and times;
6. The ultimate destination of the flow; e.g., surface water body, land use location via municipal separate storm sewer system to a surface water body (include the name of the receiving stream);
7. Corrective actions or plans to eliminate future discharges;
8. Identification of the person providing the 5 Day Written Report concerning the SSO; and



9. Reason why the required 24 Hour Report was not provided in a timely manner, if applicable.

The 5-Day Written Report will be provided to SCDHEC and shall include the appropriate signature and/or certification, in accordance with the signatory requirements of the City's NPDES Permit for the Metro Wastewater Treatment Plant (Permit).

If the SSO is still ongoing at the time the 5 Day Written Report is submitted, the Director of Utilities and Engineering or his/her designee will mark the Report "PRELIMINARY." If the SSO has ceased at the time of the 5 Day Written Report, the Director of Utilities and Engineering or his/her designee will mark the Report "FINAL."

#### **3.4.4 PROCESSING ALL SANITARY SEWER OVERFLOW REPORTS**

The Wastewater Compliance Section will indicate on the report form whether the location has overflowed within the last 12 months. All overflow locations will be loaded on the City's GIS. The Director of Utilities and Engineering or his/her designee will enter the information on the COC SSO Report Form (01/2013) (5 Day Written Report) into the "Sewer Report" Engineering Applications Program and assign a tracking number to it. This number will be written on the top right hand corner of the Report. The hard copy report form will be scanned and saved as the number assigned in an electronic file.

After the scanned Report is saved, the Director of Utilities and Engineering or his/her designee will email the Report within 5 days of the overflow to the SCDHEC and appropriate City Divisions. A listing of recent SSOs may be accessed at [http://www.scdhec.gov/environment/water/sso-psf\\_display.aspx](http://www.scdhec.gov/environment/water/sso-psf_display.aspx)

The original hard copy Report will be forwarded to the MWWTP Superintendent or his/her designee for DMR Reporting.

A copy of the electronic Report will be saved in the department's file folder and maintained for at least 3 years. Complaints from customers or others regarding SSOs will be maintained within the City's Work Order Management Program for at least 3 years.

#### **3.4.5 FECAL COLIFORM SAMPLING**

City staff will perform fecal coliform sampling during and/or following a sanitary sewer overflow event as directed by the SCDHEC in accordance with the following procedure:

1. Determine where the sanitary sewer overflow impacted the waterway.
2. Where available, utilize GIS mapping to determine if the site can be sampled above impacted area to determine waterway background levels.
3. Where possible, determine sampling location above impacted area, at impacted site, and downstream of impacted area.
4. Create map sketch showing locations or describe them in writing.

5. Ice down cooler, prep sampling equipment and sample bottles utilizing proper chain of custody techniques.
6. When entering potentially hazardous areas utilize the buddy system.
7. Use proper PPE and safe collection practices.
8. Collect sample at each location and make field notes as needed. Record: date, time, exact location of sample sites, sampler personnel information, project name. Samples will be recorded as Project name: COC-SSO location.
9. Deliver samples to lab for analysis.
10. Repeat sampling as directed by SCDHEC, MULTIPLE DAYS MAY BE NECESSARY. INFORM SCDHEC OF RESULTS AS SOON AS THEY ARE AVAILABLE so a determination can be made as quickly as possible regarding the need for additional samples.

### **3.5 PUBLIC NOTIFICATION PROCEDURE**

An appropriate Division Superintendent or his/her designee is responsible for advising the public of confirmed SSOs which potentially impact the health and safety of the public. Posting and notification will differ depending upon the location and severity of the SSO.

#### **3.5.1 TEMPORARY SIGNAGE**

An appropriate Division Superintendent or his/her designee is responsible for posting signs advising the public of a confirmed SSO as determined to be necessary pursuant to the guidelines set forth in Section 5, Appendix G herein. The placement of signage is to be determined according to the following criteria related to the location and nature of the confirmed SSO:

1. Signs should be posted at the location of a confirmed SSO which is believed to have entered "Waters of the United States", at any public access areas downstream of the SSO which may be potentially impacted by a confirmed SSO, and at the location of a confirmed SSO where cleanup and sanitizing of the site has not been completed;
2. Signs should be posted in the vicinity of a confirmed SSO where people are known to be present near a confirmed SSO or where it is obvious that people frequently visit the area (i.e., paths, trails, walkways, and so on) to alert the public to avoid the site and avoid contact with water in the general area; and
3. Temporary signage (i.e., door hangers, yard signs, and so on) may be used where posting at the location of the confirmed SSO is difficult or thought to be ineffective.

#### **3.5.2 MEDIA NOTIFICATION**

The Director of Utilities and Engineering or his/her designee will be responsible for notifying the media of an SSO in accordance with the guidelines and procedures outlined in Section 4.1 (Option 1) and Section 5, Appendix H herein.

### **3.5.3 DOWNSTREAM DRINKING WATER INTAKES**

An appropriate Division Superintendent or his/her designee will immediately notify downstream drinking water sources within 20 miles of any SSO of at least 5,000 gallons, or SSOs of any size that have the potential of flowing, being washed into, or otherwise having the potential of entering downstream water sources. If a potential SSO is not subsequently confirmed, yet the SSO is in close proximity to a drinking water intake, the downstream sources will still be notified. The 24 Hour Report as described in Section 5, Appendix B will include the location of the SSO, including the watershed potentially affected by the SSO. The SSO location and watershed information indicated in the 24 Hour Report will generally be used to identify the drinking water sources that will be notified.

## **4.0 WASTEWATER COMPLIANCE SECTION EMERGENCY RESPONSE PROCEDURES**

### **4.1 PUBLIC NOTICE FOR SSOs OF AT LEAST 5,000 GALLONS**

Public Notice Options for SSO's of at least 5,000 gallons or as deemed necessary by SCDHEC to protect public health. Field supervisors will be responsible for notifying the appropriate personnel to enact the best option on a situational basis.

1. The Director of Utilities and Engineering or his/her designee will draft a press release in accordance with Appendix H. The press release will be distributed to SCDHEC, appropriate City Departments and Divisions, local news media outlets, local MS4 permit holders, and local stakeholders. This list of press release recipients is maintained and updated within the Wastewater Compliance Section.

OR

2. The WWM Superintendent or MWWTP Superintendent or his/her designee will be responsible for postings temporary signs where a confirmed SSO has occurred and where it entered "Waters of the United States", in public access areas downstream of the SSO, where cleanup and sanitizing of the impacted site has not been completed, and in areas where people frequently visit (paths, trails, walkways, etc.). Signs should be posted as soon as possible in order to alert the public, allowing the public to avoid the site and avoid contact with impacted waterways.

OR

3. The WWM Superintendent or MWWTP Superintendent or his/her designee will be responsible for utilizing temporary signage (door hangers or yard signs) where posting signs is difficult or thought to be ineffective. This method will also be utilized for overflows that are localized and isolated as deemed appropriate in heavily populated areas.

## 5.0 APPENDICES

### 5.1 APPENDIX A: DISPATCHER PLAN PROTOCOL

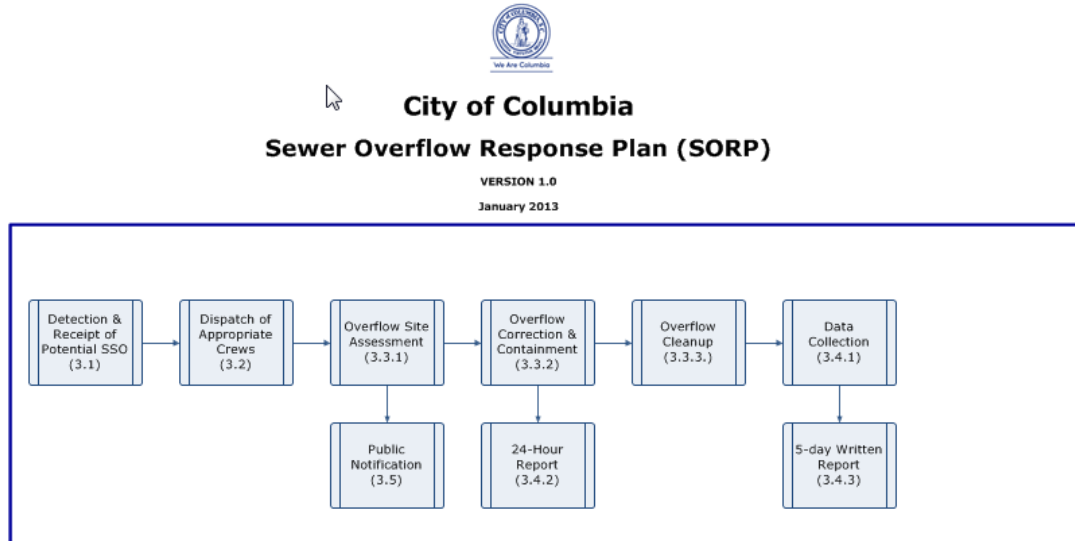

### 5.2 APPENDIX B: 24 HOUR REPORT CHECKLIST

The 24-hour report left on voice mail will include, at a minimum, the following information:

1. Identification of the utility name, person reporting the SSO, and a contact number;
2. Date and start time of the SSO failure;
3. Location of the SSO by street address or other appropriate method; and
4. Whether the SSO is reaching "Waters of the United States." According to the United States Environmental Protection Agency 40 CFR 230.3, Waters of the United States are defined as:
  - a. All waters which are currently used, or were used in the past, or may be susceptible to use in interstate or foreign commerce, including all waters which are subject to the ebb and flow of the tide;
  - b. All interstate waters including interstate wetlands;
  - c. All other waters such as intrastate lakes, rivers, streams (including intermittent streams), mudflats, sand flats, wetlands, sloughs, prairie potholes, wet meadows, playa lakes, or natural ponds, the use, degradation or destruction of which could affect interstate or foreign commerce including any such waters:
    - (i) Which are or could be used by interstate or foreign travelers for recreational or other purposes; or

- (ii) From which fish or shellfish are or could be taken and sold in interstate or foreign commerce; or
  - (iii) Which are used or could be used for industrial purposes by industries in interstate commerce;
  - d. All impoundments of waters otherwise defined as waters of the United States under this definition;
  - e. Tributaries of waters identified in paragraphs (s) (1) through (4) of this section;
  - f. The territorial sea;
  - g. Wetlands adjacent to waters (other than waters that are themselves wetlands) identified in paragraphs (s) (1) through (6) of this section; waste treatment systems, including treatment ponds or lagoons designed to meet the requirements of CWA (other than cooling ponds as defined in 40 CFR 423.11(m) which also meet the criteria of this definition) are not waters of the United States.
5. Potential water intakes that could be affected by a SSO:  
(Located within 20 miles of Columbia, South Carolina)
- a. **City of Columbia Lake Murray Water Treatment Plant**  
Contact the Control Room at 803-781-2181
  - b. **City of Columbia Canal Water Treatment Plant**  
Contact the Control Room at 803-733-8336
  - c. **City of West Columbia Lake Murray Filtering Plant**  
Contact the Control Room at 803- 957-4596
  - d. **City of West Columbia Filtering Plant**  
Contact the Control Room at 803-794-7696
  - e. **The City of Cayce Water Treatment Plant**  
Contact the Control Room at 803-739-5367

5.3 APPENDIX C: 5 DAY WRITTEN REPORT
CITY OF COLUMBIA SANITARY SEWER OVERFLOW REPORT FORM (04/2013)



SSO No.: \_\_\_\_\_

City of Columbia Sewer System Overflow Report Form

Permit: City of Columbia Permit No: SC0020940 Effected County: \_\_\_\_\_
(Richland or Lexington)

Date SSO Failure: \_\_\_\_\_ Time: \_\_\_\_\_ Response Person: \_\_\_\_\_
(Military Format) (City Personnel)

Date SCDHEC Notified: \_\_\_\_\_ Time: \_\_\_\_\_ Person Contacted: \_\_\_\_\_
(Military Format) (SCDHEC Personnel)

Description of Source (manhole, pump station, etc.): \_\_\_\_\_ Pump Station No.: \_\_\_\_\_

Location of SSO/Failure: \_\_\_\_\_ Basin: \_\_\_\_\_
(Street address) (City, State, Zip)

City Limits: \_\_\_\_\_ Contributing Area: \_\_\_\_\_
(Inside or Outside) (Apartment, Residential, Commercial, Plant Related)

Cause of SSO/Failure: \_\_\_\_\_
(Grease, Roots, Collapsed Line, Broken Line or if other-please explain)

Control Action Taken to Minimize Flow: \_\_\_\_\_

Corrective Action Taken to respond to and clean up: \_\_\_\_\_

Estimate volume of wastewater released: \_\_\_\_\_
(In Gallons)

Has an overflow occurred at this location within the past 12 months? Yes \_\_\_ No \_\_\_: If Yes, When? \_\_\_

Did wastewater enter a stream or body of water? Yes \_\_\_ No \_\_\_: Was sample taken? Yes \_\_\_ No \_\_\_
(If discharge reaches any water already present in a conveyance ditch, etc., it is considered to have reached waters of the State)

If Yes, Where? \_\_\_\_\_
(Name of water body)

Were down stream water-in-takes notified? Yes \_\_\_ No \_\_\_ If Yes, who? \_\_\_\_\_

Was public notification issued? Yes \_\_\_ No \_\_\_ If Yes, what type? \_\_\_\_\_
(Door-hanger, Signage, Press Release)

Date Corrective Action Completed: \_\_\_\_\_ Time: \_\_\_\_\_ Work Order No.: \_\_\_\_\_
(Military Format)

Date Cleanup Action Taken: \_\_\_\_\_ Time: \_\_\_\_\_
(Military Format)

Describe actual cleanup process: \_\_\_\_\_

Phone: \_\_\_\_\_
(Name/Signature of Person Initiating Action)

Date: \_\_\_\_\_

(Signature/Sewer System Other Responsible Individual)

Date: \_\_\_\_\_

## **5.4 APPENDIX D: DISCHARGE MONITORING REPORT REQUIREMENTS**

### **SUMMARY REPORT SUBMITTED WITH THE SCHEDULED DMR FORM**

In addition to the 24 hour report and 5 day report, the NPDES permit also requires The City of Columbia to submit, along with the scheduled Discharge Monitoring Report (DMR) Form, the following information for each SSO at each source (this means all SSOs, including those that do not reach waters of the US and those that are less than 500 gallons in volume) that occurs during the reporting period covered by the DMR Form:

1. Duration and volume (estimate if unknown) of the SSO;
2. Location of the SSO by street address or other appropriate method;
3. Cause of the SSO;
4. Description of the source, (e.g., manhole cover, pump station);
5. Exact dates and times of the SSO event, (i.e., start and stop dates and times);
6. The ultimate destination of the flow; (e.g., surface water body), and name of receiving water;
7. Corrective actions or plans to eliminate future discharges; and
8. Identification of the person providing the written report concerning the SSO.

(NOTE: The NPDES permit includes a requirement that The City of Columbia identify whether the collection system is combined or separate. The Water Programs Enforcement Branch (WPEB) is aware that the collection systems of the South Carolina NPDES permittees of interest are separate and this requirement has intentionally been omitted from this SORP.)

The summary report submitted with the DMR shall contain all overflow volumes and a copy of each of the "FINAL" COC SSO reporting forms from the DMR reporting period.



### 5.5 APPENDIX E: OVERFLOW CALCULATING

A variety of approaches exist for the estimation of the volume of a sanitary sewer overflow. The following methods are most commonly employed. Other methods are also possible. Every effort shall be made to estimate the overflow volume as accurately as possible:

1. Historic pump run times;
2. Historic flow data;
3. Assessment of pooled SSO including dimensions of affected area (see example 1 below); and
4. Calculations of estimated overflow from manhole (see example 2 below).

**Rectangular Area Calculation Sheet for SSO Reporting**  
(Volumes from Chart are shown in Gallons per Inch Depth)

|       |     | Length |      |      |      |      |      |       |       |       |       |      |
|-------|-----|--------|------|------|------|------|------|-------|-------|-------|-------|------|
|       |     | 5      | 10   | 20   | 30   | 40   | 50   | 60    | 70    | 80    | 90    | 100  |
| Width | 5   | 16     | 31   | 62   | 94   | 125  | 156  | 187   | 218   | 249   | 281   | 312  |
|       | 10  | 31     | 62   | 125  | 187  | 249  | 312  | 374   | 436   | 499   | 561   | 623  |
|       | 15  | 47     | 94   | 187  | 281  | 374  | 468  | 561   | 655   | 748   | 842   | 935  |
|       | 20  | 62     | 125  | 249  | 374  | 499  | 623  | 748   | 873   | 997   | 1122  | 1247 |
|       | 25  | 78     | 156  | 312  | 468  | 623  | 779  | 935   | 1091  | 1247  | 1403  | 1558 |
|       | 30  | 94     | 187  | 374  | 561  | 748  | 935  | 1122  | 1309  | 1496  | 1683  | 1870 |
|       | 35  | 109    | 218  | 436  | 655  | 873  | 1091 | 1309  | 1527  | 1745  | 1964  | 2182 |
|       | 40  | 125    | 249  | 499  | 748  | 997  | 1247 | 1496  | 1745  | 1995  | 2244  | 2493 |
|       | 45  | 140    | 281  | 561  | 842  | 1122 | 1403 | 1683  | 1964  | 2244  | 2525  | 2805 |
|       | 50  | 156    | 312  | 623  | 935  | 1247 | 1558 | 1870  | 2182  | 2493  | 2805  | 3117 |
|       | 55  | 171    | 343  | 686  | 1029 | 1371 | 1714 | 2057  | 2400  | 2743  | 3086  | 3428 |
|       | 60  | 187    | 374  | 748  | 1122 | 1496 | 1870 | 2244  | 2618  | 2992  | 3366  | 3740 |
|       | 65  | 203    | 405  | 810  | 1216 | 1621 | 2026 | 2431  | 2836  | 3241  | 3647  | 4052 |
|       | 70  | 218    | 436  | 873  | 1309 | 1745 | 2182 | 2618  | 3054  | 3491  | 3927  | 4363 |
|       | 75  | 234    | 468  | 935  | 1403 | 1870 | 2338 | 2805  | 3273  | 3740  | 4208  | 4675 |
|       | 80  | 249    | 499  | 997  | 1496 | 1995 | 2493 | 2992  | 3491  | 3989  | 4488  | 4987 |
|       | 85  | 265    | 530  | 1060 | 1590 | 2119 | 2649 | 3179  | 3709  | 4239  | 4769  | 5298 |
|       | 90  | 281    | 561  | 1122 | 1683 | 2244 | 2805 | 3366  | 3927  | 4488  | 5049  | 5610 |
|       | 95  | 296    | 592  | 1184 | 1777 | 2369 | 2961 | 3553  | 4145  | 4737  | 5330  | 5922 |
|       | 100 | 312    | 623  | 1247 | 1870 | 2493 | 3117 | 3740  | 4363  | 4987  | 5610  | 6233 |
|       | 105 | 327    | 655  | 1309 | 1964 | 2618 | 3273 | 3927  | 4582  | 5236  | 5891  | 6545 |
|       | 110 | 343    | 686  | 1371 | 2057 | 2743 | 3428 | 4114  | 4800  | 5485  | 6171  | 6857 |
|       | 115 | 358    | 717  | 1434 | 2151 | 2867 | 3584 | 4301  | 5018  | 5735  | 6452  | 7168 |
|       | 120 | 374    | 748  | 1496 | 2244 | 2992 | 3740 | 4488  | 5236  | 5984  | 6732  | 7480 |
|       | 125 | 390    | 779  | 1558 | 2338 | 3117 | 3896 | 4675  | 5454  | 6233  | 7013  | 7792 |
|       | 130 | 405    | 810  | 1621 | 2431 | 3241 | 4052 | 4862  | 5672  | 6483  | 7293  | 8103 |
|       | 135 | 421    | 842  | 1683 | 2525 | 3366 | 4208 | 5049  | 5891  | 6732  | 7574  | 8415 |
|       | 140 | 436    | 873  | 1745 | 2618 | 3491 | 4383 | 5236  | 6109  | 6981  | 7854  | 8727 |
| 145   | 452 | 904    | 1808 | 2712 | 3615 | 4519 | 5423 | 6327  | 7231  | 8135  | 9038  |      |
| 150   | 468 | 935    | 1870 | 2805 | 3740 | 4675 | 5610 | 6545  | 7480  | 8415  | 9350  |      |
| 155   | 483 | 966    | 1932 | 2899 | 3865 | 4831 | 5797 | 6763  | 7729  | 8696  | 9662  |      |
| 160   | 499 | 997    | 1995 | 2992 | 3989 | 4987 | 5984 | 6981  | 7979  | 8976  | 9973  |      |
| 165   | 514 | 1029   | 2057 | 3086 | 4114 | 5143 | 6171 | 7200  | 8228  | 9257  | 10285 |      |
| 170   | 530 | 1060   | 2119 | 3179 | 4239 | 5298 | 6358 | 7418  | 8477  | 9537  | 10597 |      |
| 175   | 545 | 1091   | 2182 | 3273 | 4363 | 5454 | 6545 | 7636  | 8727  | 9818  | 10908 |      |
| 180   | 561 | 1122   | 2244 | 3366 | 4488 | 5610 | 6732 | 7854  | 8976  | 10098 | 11220 |      |
| 185   | 577 | 1153   | 2306 | 3460 | 4613 | 5766 | 6919 | 8072  | 9225  | 10379 | 11532 |      |
| 190   | 592 | 1184   | 2369 | 3553 | 4737 | 5922 | 7106 | 8290  | 9475  | 10659 | 11843 |      |
| 195   | 608 | 1216   | 2431 | 3647 | 4862 | 6078 | 7293 | 8509  | 9724  | 10940 | 12155 |      |
| 200   | 623 | 1247   | 2493 | 3740 | 4987 | 6233 | 7480 | 8727  | 9973  | 11220 | 12467 |      |
| 205   | 639 | 1278   | 2556 | 3834 | 5111 | 6389 | 7667 | 8945  | 10223 | 11501 | 12778 |      |
| 210   | 655 | 1309   | 2618 | 3927 | 5236 | 6545 | 7854 | 9183  | 10472 | 11781 | 13090 |      |
| 215   | 670 | 1340   | 2680 | 4021 | 5361 | 6701 | 8041 | 9381  | 10721 | 12062 | 13402 |      |
| 220   | 686 | 1371   | 2743 | 4114 | 5485 | 6857 | 8228 | 9599  | 10971 | 12342 | 13713 |      |
| 225   | 701 | 1403   | 2805 | 4208 | 5610 | 7013 | 8415 | 9818  | 11220 | 12623 | 14025 |      |
| 230   | 717 | 1434   | 2867 | 4301 | 5735 | 7168 | 8602 | 10036 | 11469 | 12903 | 14337 |      |
| 235   | 732 | 1465   | 2930 | 4395 | 5859 | 7324 | 8789 | 10254 | 11719 | 13184 | 14648 |      |
| 240   | 748 | 1496   | 2992 | 4488 | 5984 | 7480 | 8976 | 10472 | 11968 | 13464 | 14960 |      |
| 245   | 764 | 1527   | 3054 | 4582 | 6109 | 7636 | 9163 | 10690 | 12217 | 13745 | 15272 |      |
| 250   | 779 | 1558   | 3117 | 4675 | 6233 | 7792 | 9350 | 10908 | 12467 | 14025 | 15583 |      |

$$\text{Total Spill Volume} = \frac{\text{Value from Chart}}{\text{Depth in Inches}} \times \text{Depth in Inches} = \text{Volume in Gallons}$$

### Example 1



Volume Estimation Guide

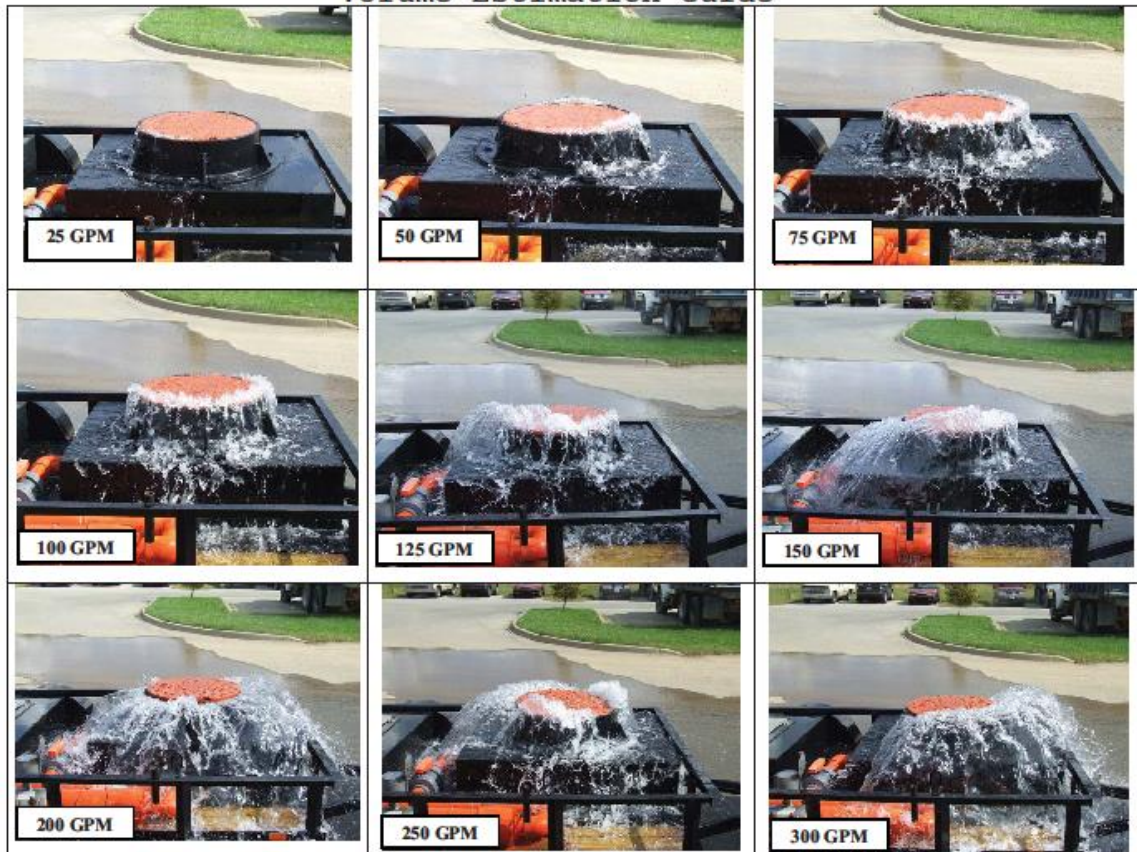

August 2008

**Example 2**

## 5.6 APPENDIX F: DISINFECTANT HANDLING AND RESPONSIBILITIES

Lime is used in an attempt to kill potential pathogens.

Soil – In some cases (e.g., pipe replaced and backfilled with dirt) it may be acceptable to cover the affected area with clean relatively dry dirt. This will allow “natural” remediation of any organic residues of the SSO similar to the way a septic tank leach field system works, and will let the public immediately access the affected areas.

Lime – Lime or calcium oxide can be applied to ground surfaces where a SSO has occurred. Lime is chemically very basic. Lime can cause burns to human skin and injure eyes due to its basic characteristics. The SCDHEC recommendations, product label, and material safety data sheet should always be followed when applying lime. After application of lime, the soil affected by the SSO and lime application may need to be removed and disposed of properly. The area may have to remain posted until the soil is removed. In some cases the area may have to be raked and lime reapplied.

## 5.7 APPENDIX G: PUBLIC NOTIFICATION SIGNAGE

The responsibility for determining whether signage is necessary for areas affected by wastewater flows in part is determined by the Division that will be responsible for assessing, containing, correcting, and clean-up of the SSO. SSOs that originate in pumping stations and the collection system may involve personnel in more than one division and the appropriate division should relay the information of the action being taken to the proper foreman, supervisors, and managers. Two main factors in determining when and where to post signs are the degree of public access and the effectiveness of the clean-up of the affected area. The posting of signage will not necessarily prohibit use or access to the area unless posted otherwise, but will provide a temporary warning of potential public health risks associated with the recent SSO (e.g., heavy flushing of an area making it impractical to recover all of the wash down water commingled with wastewater). For most SSOs in the collection system, the first responders in consultation with the Wastewater Maintenance Foreman, Assistant Superintendent and or I & I personnel will make the decision regarding posting. The Department Head and his/her designee should be involved, when appropriate, in the decision making process.

If the decision to post has been made regarding SSOs to surface waters, ground surfaces, or structures and there is concern if the notification is sufficient, then the Director of Utilities & Engineering should be involved and additional public notifications may be necessary. Examples of signage and door hangers are included below.

Circumstances under which further public notification may be considered include, but are not limited to, the following:

1. When permanent repairs to resolve a SSO will take a period of time (e.g., estimated 24-48 hours) and the reduction in the usage of water in homes or business would assist in managing the operation of the locally affected pipeline, pumping station, or wastewater plant.

2. When a more permanent repair or replacement is needed to prevent recurrence and the actions will take a period of time (e.g., estimated 24 – 48 hours) and citizens need to be advised of repair schedules and possible traffic detours in the vicinity of the repairs (e.g., pumping station and pump-around operation, pipeline crossing road way, and so on).

**Signage Example:**

|  |  |
|--|--|
| <p><b>CAUTION:</b><br/><b>SANITARY SEWER<br/>OVERFLOW SITE</b></p> <p>The City of Columbia has<br/>experienced a sewer<br/>overflow in this area.</p> <p><b>AVOID CONTACT, KEEP<br/>CHILDREN AND PETS AWAY.</b></p> <p>For information regarding<br/>this overflow, call the<br/>City of Columbia Wastewater<br/>Maintenance Division at<br/>803-545-3300.</p> | <p><b>CUIDADO:</b><br/><b>DERRAMAMIENTO DE<br/>DRENAJE SANITARIO</b></p> <p>La Ciudad de Columbia ha<br/>experimentado un<br/>en esta área.</p> <p><b>EVITE CUALQUIER CONTACTO,<br/>MANTENGA A LOS NIÑOS Y<br/>ESTE LUGAR.</b></p> <p>Para información acerca de este<br/>derramamiento, llame a la<br/>División de Mantenimiento de<br/>Aguas Residuales al<br/>803-545-3300.</p> |
|--|--|

**Door Hanger Example:**  
(English Version)

# NOTICE

## SANITARY SEWER OVERFLOW

The City of Columbia has experienced an overflow in your area.

A sewer backup has occurred on \_\_\_\_\_,  
(date)

in this neighborhood at \_\_\_\_\_.  
(location)

This means that water containing sewage may have entered your yard or \_\_\_\_\_.  
(receiving water body)

Check your yard and stream/ditch and call **(803) 545-3300** if you find sewage in your yard. Do not try to clean it up yourself. Call the City of Columbia Wastewater Maintenance Division for assistance and instructions at the number above. Please avoid contact with standing water, drainage ditches or nearby streams, as it may contain sewage and stormwater runoff contaminant's that could make you sick.

### **KEEP CHILDREN AND PETS AWAY!**

• Para la version en español de la vuelta a la página •

**Department of Utilities & Engineering**  
**1136 Washington Street**  
**Columbia, SC 29201**

**Door Hanger Example:**  
(Spanish Version)

# AVISO

## DERRAMAMIENTO DE DRENAJE SANITARIO

La Ciudad de Columbia ha experimentado un derramamiento en su área.

Ha ocurrido una obstrucción en el drenaje el \_\_\_\_\_,  
(fecha)  
en este vecindario en \_\_\_\_\_.  
(lugar)

Esto significa que aguas residuales pudieron haber entrado en su patio o \_\_\_\_\_.  
(recibidor de agua)

Revise su patio y corrientes de agua/canales/zanjas u llame al (803) 545-3300 si encuentra aguas residuales en su patio. No trate de limpiarlo por usted mismo.

Llame a la División de Mantenimiento de Aguas Residuales de la Ciudad de Columbia al número antes mencionado para asistencia e instrucciones. Por favor envite contacto con aguas estancadas, canales de drenaje o ríos cercanos ya que pueden contener aguas residuales y contaminantes de escorrentía pluvial (residuos de agua de lluvia) que podrían hacer que usted se enferme.

**¡MANTENGA A LOS NIÑOS Y MASCOTAS ALEJADOS!**

- Flip the page over for the English version •

**Departamento de Utilidades y Inganiaria  
1136 Washington Street  
Columbia, SC 29201**

**5.8 APPENDIX H: PRESS RELEASE EXAMPLES**

**Example 1**

**Press Release Language- SSO Still Occurring**

City of Columbia Issues a  
Sanitary Sewer System Overflow Notification  
To  
The Customers of  
(Interstate 20 / Monticello Road Area)

December 16, 2008

The City of Columbia has experienced an overflow of sanitary sewer in the area behind the 5900 Block of Monticello Road located in Richland County.

The City of Columbia's Wastewater Maintenance Division was notified approximately at 3:30 pm on 12/15/08 of a sanitary sewer overflow. The City experienced flooding due to heavy rainfall in the collection system line at the above location. As a result, sanitary sewer was introduced into Crane Creek.

The City of Columbia's Wastewater Maintenance Division, 545-3300, may answer other inquiries concerning this Notification.

**Example 2**

**Press Release Language- SSO Under Control**

City of Columbia Issues a  
Sanitary Sewer System Overflow Notification  
To  
The Customers of  
(Northwood Hills Subdivision)

October 16, 2008

The City of Columbia has experienced an overflow of sanitary sewer in the area at 620 Glenthorne Road located in Richland County

The City of Columbia's Wastewater Maintenance Division was notified approximately at 10:00am on 10/16/08 of a sanitary sewer overflow that lasted until 12:30pm on 10/16/08, the City experienced vandalism to the collection system line, at 620 Glenthorne Road. As a result,

sanitary sewer was introduced into Crane Creek. The City has cleaned the sewer line and washed the storm drain including the creek.

The City of Columbia Wastewater Maintenance Division, 545-3300, may answer other inquiries concerning this Notification.

## 5.9 Appendix I: Stormwater Best Management Practices (BMPs) for WWM and MWWTP

|   |
|---|
| 1. Stop the discharge as quickly as possible.   |
| 2. Do not pump sewage back-ups, disinfectant or disinfected sewage into streets, storm drains, ditches or surface waters.   |
| 3. <u>Before</u> any digging begins, all inlets within a vicinity of 50 feet must be protected with sand bags, gravel bags, sediment tubes, or a combination of the three. Also protect any sensitive areas nearby including wetlands, adjacent waters, or other conveyance structures.   |
| 4. When a backup occurs and when disinfecting the contaminated area, take every effort to ensure that sewage, disinfectant and disinfected sewage is not accidentally discharged into a storm drain or ditch. Methods may include: <ul style="list-style-type: none"> <li>(a) Blocking storm drain inlets and catch basins with gravel bags, sand bags, sediment tubes, or a combination of these items.</li> <li>(b) Containing and diverting sewage, sediment and disinfectant away from open channels and other storm drain fixtures.</li> <li>(c) Removing the solid material with vacuum equipment.</li> </ul> |
| 5. Do not clean tools or equipment in or near surface waters or over storm drains or ditches. If rinsing a sand bag or sediment tube for reuse, rinse over a vegetated area so the runoff can infiltrate.   |
| 6. When activities are complete, inspect the flow path of the discharge. Identify any areas that may have experienced soil erosion and need repair. Use erosion control blankets, mulch or geo-fabric with hay matting (which can include seeds) to stabilize soil erosion. Always make every attempt to re-establish vegetation on the impacted area, and if necessary continue inspections until the area has stabilized. Contact the Stormwater Section (545-3304) with any questions or help with ongoing inspections or stabilization issues.  |
| 7. With backhoes, shovels or brooms, remove any dirt or sediment on impervious surfaces. If necessary, contact Solid Waste for use of a street sweeper.   |
| 8. Do not hose down the area to remove sediment (unless it is necessary for traffic safety).  |



## REQUIRED STRUCTURES AND EQUIPMENT

The Wastewater Department will procure the following BMPs and equipment to accomplish the procedures listed above. Equipment may be stockpiled offsite, and needed quantities will be stored in the crews' response vehicles.

- # 57 stone
- Sand
- Geotextile fabric bags (can be used with stone and sand)
- Sediment tubes
- Silt fence
- Backhoe (for sediment removal)
- Brooms and shovels

### 6.0 Appendix J: Contact Information

| Agency                                | Office Phone                       | Cell Phone | Other/Comments<br>(After – Hours) |
|---------------------------------------|------------------------------------|------------|-----------------------------------|
| Columbia<br>Police                    | 545-3500<br><i>(Non-emergency)</i> |            | 911<br><i>(Emergency)</i>         |
| Columbia<br>Fire                      | 545-3700<br><i>(Non-emergency)</i> |            | 911<br><i>(Emergency)</i>         |
| Columbia Metro<br>WWTP                | 733-8566<br>733-8575               |            | 413-8376<br><i>(After-Hours)</i>  |
| Columbia<br>Stormwater                | 545-3304                           |            |                                   |
| Columbia<br>Lake Murray WTP           | 781-2181                           |            |                                   |
| Columbia<br>Canal WTP                 | 733-8336                           |            |                                   |
| Columbia<br>Wastewater<br>Maintenance | 545-3300                           |            | 600-5619<br><i>(After-Hours)</i>  |
| Columbia<br>Public Works              | 545-3780                           |            |                                   |
| Emergency<br>Medical Services         | 911                                |            | 911                               |
| West Columbia<br>Lake Murray WTP      | 957-4596                           |            |                                   |



| <b>Agency</b>                      | <b>Office Phone</b>                  | <b>Cell Phone</b> | <b>Other/Comments<br/>(After – Hours)</b> |
|------------------------------------|--------------------------------------|-------------------|---|
| West Columbia<br>Filtering Plant   | 794-7696                             |                   |   |
| Cayce<br>WTP                       | 739-5367                             |                   |   |
| Richland County<br>Sheriff's Dept. | 576-3000<br>( <i>Non-emergency</i> ) |                   | 911<br>( <i>Emergency</i> )               |
| SCDHEC<br>Region 3 – EQC Office    | 896-0620                             |                   | 253-6488<br>( <i>After-Hours</i> )        |

## 7.0 Appendix K: Equipment List

### Sewer Blockage, Broken or Collapsed Line

| <b>Minimum Emergency Equipment</b>                            | <b>Specialized Equipment</b>   |
|---|--|
| Jet flushing unit   | Television camera unit   |
| Rodding machine & associated cleaning/cutting attachments     | Truck with hoist   |
| Standard disinfectants  | Vactor unit  |
| <b>Safety Equipment</b>                                       | Power saw (circular)   |
| Air blower with hose  | Power vacuum   |
| Portable pumps  | Pipe cutter (hydraulic)  |
| Portable generators   | Caution tape   |
| Safety cones/barricades                                       | Assorted hand tools (i.e., screwdrivers, wrenches, hammers, brooms)                          |
| Air Detector – for oxygen deficient, explosive or toxic gases | Swap loader trucks, septic tank skids, dewatering boxes, debris boxes                        |
| Confined space entry tripod and associated equipment          | ROW clearing equipment, Shin cutter, skid steer mulchers, Mini-excavators, skid steer bucket |
| Personal Protective Equipment (PPE)                           | Lowboy tractor & trailer (transport equipment)   |
| Safety harness and lifeline if applicable                     | Rubber tire/ Track excavators, dump trucks   |

### Pump Station Failure

| <b>Minimum Emergency Equipment</b> | <b>Specialized Equipment</b> |
|------------------------------------|------------------------------|
| Vactor Unit                        | Aluminum ladder              |
| Truck with hoist                   | Power vacuum                 |
| Standard disinfectants             | Pipe cutter (hydraulic)      |
| <b>Safety Equipment</b>            | Caution tape                 |

| <b>Minimum Emergency Equipment</b>                            | <b>Specialized Equipment</b>  |
|---|---|
| Air blower with hose  | Bypass pumping equipment  |
| Safety harness and lifeline if applicable                     | Assorted hand mirrors   |
| Portable pumps  | Bucket with rope  |
| Portable generators   | Aluminum ladder   |
| Safety cones/barricades                                       | Trash pumps may be required   |
| Air Detector – for oxygen deficient, explosive or toxic gases | Assorted hand tools (i.e., screwdrivers, wrenches, hammers, brooms) |
| Confined space entry tripod and associated equipment          |   |
| Flashlight  |   |
| Personal Protective Equipment (PPE)                           |   |

## **Appendix E**

**APPENDIX E**  
**City of Columbia Metro WWTP**  
**Capital Improvement Program for Columbia Metro WWTP**

Columbia has underway a Capital Improvement Program for the Columbia Metro WWTP, as described further below. The projects included in this Program are: (1) Metro WWTP Headworks Project (Capital Improvement Project (“CIP”) SS6722); (2) Aeration Improvements (CIP No. SS7182); (3) Metro WWTP Disinfection Improvements (CIP No. 7058); (4) Metro WWTP Secondary Clarifier Improvements (CIP No. SS6871); (5) Metro WWTP Train 2 Pump Station Improvements (CIP No. SS7155); and (6) Metro WWTP DAF Improvements (CIP No. SS7197). These capital improvements include construction of new Equipment as well as the upgrade and rehabilitation of existing Equipment. The schedule for the Capital Improvement Program for Columbia Metro WWTP is as follows:

**Project 1: SS6722 – Metro WWTP Headworks Project**

Project Description: Construction is underway of a new 150 mgd (firm capacity) influent pump station (IPS) and preliminary treatment facility (PTF) at the Metro WWTP. The IPS consists of a 2-stage lift station with screw pumps. The PTF includes mechanical barscreens and vortex grit tanks. Flow distribution is also provided to split flow to Liquid Treatment Trains 1 and 2, and to divert flow to the flow equalization lagoon.

Construction Start Date:

July 2010

Construction Completion Date:

June 30, 2014

**Project 2: SS7182 – Aeration Improvements**

Project Description: This project includes aeration tank improvements which are designed to upgrade the older existing components. This project will focus on the replacement of the diffuser heads within the Train 2 aeration tanks. Complete replacement of the aeration diffusers rather than partial replacement is critical for maintaining a working balance between the aeration blower pressures/air flows and fine bubble diffusers for optimal system performance. Approximately 2,700 diffuser heads will be replaced.

Start Date:

January 2014

Completion Date:

December 31, 2015

**Project 3: SS7058 – Metro WWTP Disinfection Improvements**

**Construction Completed** – SCDHEC Permit to Operate in process

**Project 4: SS6871 – Secondary Clarifier Improvements at the WWTP**

Project Description: This project involves improvements within Treatment Trains Nos. 1 and 2 and includes the refurbishment of existing secondary clarifiers Nos. 1 through 10. Existing mechanical equipment will be replaced, and new electrical and instrumentation work and miscellaneous other work tasks will be included in this area.

Construction Start Date:

November 2011

Construction Completion Date:

June 30, 2014

**Project 5: SS7155 – Metro WWTP Train 2 Pump Station Improvements**

**Construction Completed** – SCDHEC Permit to Operate in process

**Project 6: SS7197 – Metro WWTP DAF Improvements**

Project Description: Replace flights in Train 2 DAF basins. As part of this project, other ancillary equipment in the basins will be assessed.

Construction Start Date:

July 2012

Construction Completion Date:

December 31, 2013

## **Appendix F**

**APPENDIX F**  
**City of Columbia WCTS**  
**Capital Improvement Program for Wastewater**  
**Collection and Transmission System**

Columbia has underway a Capital Improvement Program for the Wastewater Collection and Transmission System, as described further below. The projects included in this Program are: (1) Broad River Pump Station Improvements (CIP No. SS7101); (2) North Columbia Pump Station Improvements (CIP No. SS7102); (3) West Columbia Pump Station Improvements (CIP No. SS711501); (4) Installation of 20,000 Linear Feet of 42-inch Forcemain from West Columbia Pump Station to WWTP (CIP No. SS711502); and (5) Saluda River Pump Station Improvements (CIP No. SS7116). The schedule for the Capital Improvement Program for Columbia's WCTS is as follows:

**Project 1: SS7101 – Broad River Pump Station Improvements**

Project Description: Expand pump station capacity from 5 MGD to 9 MGD. Project includes new piping, new dry pit sewage pumps, new pump control valves, hydraulic surge protection, flow metering, new bypass connections and sump, generator, new electrical conduits and associated power and control wiring, channel grinders, SCADA improvements, a new liner system for the wetwell, and rehabilitation of influent manholes.

Construction Start Date:

June 2010

Construction Completion Date:

June 30, 2013

**Project 2: SS7702- North Columbia Pump Station Improvements**

Project Description: Modifications and rehabilitation to the North Columbia Pump Station including incorporation of VFDs for each pump and a new control system; relocation of all electrical equipment to a new electrical building; addition of two channel



grinders; modifications to the existing pump station building to improve access for pump removal including a new bridge crane system; and SCADA improvements.

Construction Start Date:

June 2010

Construction Completion Date:

December 31, 2013

**Project 3: SS711501 – West Columbia Pump Station Improvements**

Project Description: The project consists of rebuilding the existing West Columbia Pump Station. Work includes construction of a new trench style wet-well, above grade structural steel platforms for power, I&C and transformer equipment, monorail and hoist systems, influent cast-in-place reinforced concrete channel, junction and vault structures, four 8 MGD submersible pumps and one grinder, yard piping, electrical and instrumentation and control equipment, and a standby power generator.

Construction Start Date:

June 2011

Construction Completion Date:

December 31, 2013

**Project 4: SS711502 – Installation of 20,000 Linear Feet of 42-Inch Force Main from West Columbia Pump Station to Metro WWTP**

Project Description: A new 42-inch force main from the City of Columbia's West Columbia Pump Station, and approximately 21,000 feet of force main to the City's Metro Wastewater Treatment Plant. The route of the force main generally follows the alignment of the existing 60" gravity sewer interceptor and the Congaree River. The force main will convey sewage from the discharge of the West Columbia Pump Station to the Metro WWTP new Headworks.

Construction Start Date:

July 2012

Construction Completion Date:

December 31, 2013

**Project 5: SS7116 – Saluda River Pump Station Improvements**

Project Description: The project includes refurbishing the existing Saluda River Pump Station to provide increased reliability, capacity, and wet weather storage. The work consists of constructing a new export pump station in a trench style wet well with four 5 MGD submersible pumps, a new grinder structure, and two storage tanks, and converting the existing station into a storage pump station with four 10 MGD dry-pit submersible pumps. All new electrical, instrumentation and control equipment will be located within the existing pump station structure, in a newly enclosed control room. The existing pumping equipment will remain in service during the construction of the new pumping station in order to minimize, or eliminate, the need for temporary by-pass pumping.

Construction Start Date:

July 2012

Construction Completion Date:

June 30, 2015

# Appendix G

## FATS, OILS, AND GREASE MANAGEMENT REGULATION



### PART 29

#### 1. PURPOSE

This regulation will be enforced in conjunction with the City of Columbia, South Carolina, Code of Ordinances, Chapter 23 (Chapter 23), and establishes uniform registration, operating, maintenance, cleaning, and inspection requirements designed to limit and control the discharge of fats, oils, and grease from Food Service Establishments (FSEs) into the City's wastewater collection system. The objectives of this regulation include the following:

- 1.1. To reduce the introduction of excessive amounts of fats, oils, and grease into City of Columbia (City) wastewater collection system;
- 1.2. To reduce fats, oils, and grease related build-up to the City's wastewater collection system that could lead to clogging or blocking of the sewer lines, causing backup and flooding of streets, residences, and commercial buildings, resulting in potential liability to the City;
- 1.3. To establish uniform identification numbers along with registration procedures and Global Positioning System Coordinates to be input into GIS to identify food service establishments located within the City wastewater service area;
- 1.4. To establish operation, cleaning, and maintenance requirements for food service establishments with grease traps and/or grease interceptors;
- 1.5. To establish inspection procedures and requirements for food service establishments with grease traps and/or grease interceptors;
- 1.6. To establish review procedures and reporting requirements for food service establishments installing new grease traps and/or grease interceptors; and

1.7. To establish enforcement procedures for violations of Chapter 23 and any provision of this regulation.

2. **DEFINITIONS**

2.1. *Director* means the City's Director of Utilities and Engineering.

2.2. *Fats, Oils, and Grease (FOG)* means any material, either liquid or solid, composed primarily of fats, oils, and grease from animal or vegetable sources.

2.3. *Food Service Establishment (FSE)* means any commercial facility, including, by way of example and without limitation, restaurants, motels, hotels, cafeterias, hospitals, schools, bars, and any other facility which, in the sole discretion of the City, must install a Grease Trap or Grease Interceptor prior to discharging kitchen or food preparation wastewater into the City's wastewater collection system. This definition includes, but is not limited to, any establishment which is required to have a South Carolina Department of Health and Environmental Control (SCDHEC) food service license and/or permit.

2.4. *FSE Owner* or *Owner* means, in the case of an individually owned FSE, the Owner(s) and/or proprietor(s) of the FSE. Where the FSE is a franchise operation, the Owner of the franchise is the responsible person and/or entity and is considered the FSE Owner. Where the FSE is owned by a corporation, the corporate representative, as designated on the FOG Registration form, is deemed to be authorized to act on behalf of the corporation. Where two or more FSEs share a common Grease Interceptor, the FSE Owner is any individual and/or entity who owns and/or assumes, maintains, or exercises control of the Grease Interceptor or the property on which the Grease Interceptor is located, as well as any individual and/or entity who utilizes or will utilize the shared Grease Interceptor.

2.5. *Gray Water* means all of the liquid contained in a Grease Trap or Grease Interceptor that lies below the floating grease layer and above the bottom solids layer.

2.6. *Grease* means a material, either liquid or solid, composed primarily of fats, oils, and grease from animal or vegetable sources. The terms "FOG," "oil and grease," and "oil and grease substances" shall all be included within this definition and these terms may be used interchangeably.

2.7. *Grease Hauler* means a person or entity that collects the contents of Grease Traps and/or Grease Interceptors and transports the contents to an approved recycling or disposal facility. A Grease Hauler may also provide other

services to FSEs related to Grease Trap and/or Grease Interceptor cleaning and maintenance.

- 2.8. *Grease Interceptor* means a large underground concrete vault located outside of an FSE designed to collect, contain, or remove Grease from the waste stream while allowing the sub-straight or Gray Water to discharge to the wastewater collection system by gravity.
- 2.9. *Grease Trap* means a device located within an FSE designed to collect, contain, separate, or remove Grease from the waste stream while allowing the sub-straight waste or Gray Water to discharge to the wastewater collection system by gravity.
- 2.10. *Inspector or City Staff* means an employee of the City, who under the authority of the Director, has responsibility for implementing and who does implement any FOG management regulations.
- 2.11. *Program* means the contents of this regulation, Part 29, as implemented by the Director, Inspectors, and City Staff.

**3. GREASE TRAPS AND GREASE INTERCEPTORS**

- 3.1. **Requirements:** All FSEs located within the City of Columbia wastewater service area are required to have a Grease Trap and/or Grease Interceptor properly installed and maintained in accordance with the following: this regulation - *Fats, Oils, and Grease Management – Part 29; Specifications for Grease Traps and Grease Interceptors Regulation - Part 30*; and all applicable requirements of the City's most recently adopted version of the International Plumbing Code.
- 3.2. **New FSEs:** FSEs which are proposed or newly constructed, and existing FSEs undergoing a change of use which necessitates the issuance of a new SCDHEC food service permit, expansion, or renovation to provide food services, are considered New FSEs. All New FSEs are required to install Grease Traps and/or Grease Interceptors, as appropriate, in compliance with the *City of Columbia Grease Trap and Interceptor Sizing Guide* (located at *Specifications for Grease Traps and Interceptors Regulation - Part 30, Attachment C*). New FSEs are required to operate, maintain, clean, and repair their Grease Traps and Grease Interceptors according to and in compliance with all applicable provisions contained in this regulation. In situations where it is not feasible for a New FSE to install an underground Grease Interceptor, the New FSE is required to install adequate and approved Grease Traps for use on individual fixtures, including, but not limited to: pot sinks, mop sinks, pre-rinse sinks, wok ovens, floor drains, and

any other drains where the potential for introduction of Grease exists. In such cases, Grease Traps will be considered adequate and will be approved by the City only if a flow control device is placed on the inlet that prevent overloading and a sample port is placed on the outlet of each Grease Trap.

- 3.3. **Existing FSEs:** Except as provided in Subsection 3.3.1 below, Existing FSEs, which are those FSEs already operating with Grease Traps and/or Grease Interceptors that were installed prior to the effective date of this regulation, will generally be permitted to operate and maintain existing Grease Traps and Grease Interceptors provided they are in proper operating condition and are maintained, cleaned, and repaired in accordance with all applicable provisions contained in this regulation and/or Chapter 23. In the event of noncompliance with this regulation or Chapter 23, the City may, in its sole discretion: (1) allow modifications to be made by the FSE, at the FSE's own expense, to the existing Grease Trap or Grease Interceptor in order to bring it into compliance; or (2) require that the existing FSE install, at its own expense, a new Grease Trap and/or Grease Interceptor that meets the requirements of this and all other applicable laws and regulations including, without limitation, *Specifications for Grease Traps and Interceptors Regulation - Part 30* and Chapter 23.

3.3.1 *Grease Traps and Grease Interceptors installed prior to the effective date of this regulation.* If a Grease Trap or Grease Interceptor installed prior to the effective date of this regulation does not allow for measurement and sampling to demonstrate that the Grease Trap or Grease Interceptor is in compliance with this regulation and Chapter 23, the FSE must modify or replace the Grease Trap or Grease Interceptor as provided below no later than December 31, 2018:

- (a) The City, in its sole discretion, may approve a proposed modification of an existing Grease Trap or Grease Interceptor which allows for measurement and sampling of the existing Grease Trap or Grease Interceptor to demonstrate that the Grease Trap or Grease Interceptor is in compliance with this regulation and Chapter 23. Any proposed modification to meet this requirement must be submitted to the City for review no later than June 30, 2018; or
- (b) If not modified pursuant to (a) above, the existing Grease Trap or Grease Interceptor must be replaced with a new Grease Trap or Grease Interceptor, as appropriate, in compliance with the *City of Columbia Grease Trap and Interceptor Sizing Guide* (located at *Specifications for Grease Traps and Interceptors Regulation - Part 30, Attachment C*).

- 3.4. **Plumbing Connections:** Grease Traps and Grease Interceptors shall be installed in accordance with the requirements contained in all applicable local

plumbing codes. Any Grease Trap and/or Grease Interceptor shall be located in the FSE's lateral sewer line between all fixtures which may introduce Grease into the City's wastewater collection system. Wastewater from domestic facilities and other similar fixtures shall not be introduced into a Grease Trap and/or Grease Interceptor by the FSE under any circumstances.

3.5. **Grease Traps.** All Grease Traps shall be installed in accordance with the City's most recently adopted version of the International Plumbing Code. Each FSE shall operate and maintain its Grease Trap in accordance with the following criteria:

3.5.1 *Sizing.* All Grease Traps shall be sized in accordance with the City of Columbia Grease Trap and Interceptor Sizing Guide (located at *Specifications for Grease Traps and Grease Interceptors Regulation - Part 30, Attachment C*).

3.5.2 *Flow control device and sample port.* FSEs are responsible for equipping Grease Traps with a device on the inlet side to control the rate of flow through the Grease Trap. The rate of flow shall not exceed the manufacturer's rated capacity in gallons per minute for each Grease Trap. FSEs are also responsible for equipping Grease Traps with a sample port on the outlet side.

3.5.3 *Installation, inspection, cleaning, and maintenance.* Each FSE shall be solely responsible for the cost of Grease Trap installation, inspection, cleaning, and maintenance. Each FSE must either contract with a Grease Hauler cleaning service or develop a written protocol for and perform its own Grease Trap cleaning and maintenance procedures that meet the requirements of this Program. Cleaning shall include the complete removal of all floating materials, Gray Water, and bottom solids from the Grease Trap. The return of Gray Water back into the Grease Trap or into the City's the wastewater collection system is prohibited. Grease Trap cleaning must include removing/scraping excess solids from walls, floors, baffles, and inlet and outlet piping. It is the responsibility of each FSE to inspect its Grease Trap during and after the pumping and cleaning procedure to ensure that the Grease Trap is properly cleaned out and that the structure is sound and all fittings and fixtures inside the Grease Trap are in working condition and are functioning properly. The FSE Owner must have documentation consisting of inspection, cleaning, and maintenance logs on site in accordance with and demonstrating compliance with this regulation and must be able to produce the documentation immediately upon request of the Inspector and/or City Staff.



- 3.5.4 *Grease Trap Cleaning Frequency.* Cleaning and maintenance should generally be performed in accordance with the Grease Trap manufacturer's recommendations. However, despite this provision, cleaning and maintenance must be performed as often as and in the manner necessary to achieve full compliance with Chapter 23 and this regulation, even if such cleaning and maintenance exceeds that recommended by the manufacturer.
- 3.5.5 *Inspection.* Grease Traps shall be inspected by the Inspector as often as necessary in the City's sole discretion to ensure compliance with Chapter 23, and this regulation, and to determine if proper cleaning and maintenance schedules as set forth herein are being adhered to by the FSE. FSEs with Grease Traps are responsible for having qualified staff on hand during any inspection to open and close the Grease Trap.
- 3.5.6 *Repairs and replacement.* Each FSE shall be solely responsible for the cost, scheduling, and performance of all repairs and replacements to its Grease Trap(s), including, without limitation, any and all repairs and replacements that may be required by the Inspector and/or City Staff under this Program.

3.6. ***Grease Interceptors:*** Grease Interceptors shall be designed and installed in accordance with *Specifications for Grease Traps and Interceptors – Part 30* and the City's most recently adopted version of the International Plumbing Code. In the event of a conflict between the two, the most stringent requirements shall apply. Each FSE shall operate and maintain its Grease Interceptor in accordance with the following criteria:

- 3.6.1 *Installation, inspection, cleaning, and maintenance.* Each FSE shall be solely responsible for the costs of installing, inspecting, pumping, cleaning, and maintaining its Grease Interceptor(s). All FSEs that have Grease Interceptors shall utilize a Grease Hauler to properly dispose of Grease Interceptor contents. Cleaning shall include the complete removal of all Grease Interceptor contents including floating materials, Gray Water, and bottom solids. The return of Gray Water back into the Grease Interceptor or into the City's wastewater collection system is prohibited. Grease Interceptor cleaning must be performed as often as and in a manner necessary to achieve compliance with Chapter 23 and this regulation. Such cleaning may include removing/scraping and/or hydroscrubbing excessive solids from the walls, floors, baffles and all interior plumbing. It shall be the responsibility of each FSE to inspect its Grease Interceptor during the pumping and cleaning procedure to ensure that the Grease Interceptor is properly cleaned out and that the structure is sound and all fittings and fixtures inside the Grease Interceptor are in working

condition and functioning properly. The FSE Owner must have documentation consisting of inspection, cleaning, and maintenance logs on site in accordance with and demonstrating compliance with this regulation and must be able to produce the documentation immediately upon request of the Inspector and/or City Staff.

3.6.2 *Grease Interceptor cleaning frequency.* Each FSE shall have its Grease Interceptor(s) cleaned at a minimum frequency of twice per year. In addition to this required cleaning, each FSE shall determine an additional frequency at which its Grease Interceptor(s) shall be cleaned in accordance and in compliance with each of the following criteria:

3.6.2.1 When the floatable Grease layer exceeds six inches in depth as measured with an approved dipping method;

3.6.2.2 When the settleable solids layer exceeds eight inches in depth as measured with an approved dipping method;

3.6.2.3 When the total volume of captured Grease and solid material displaces more than 25 percent of the capacity of the Grease Interceptor as calculated with an approved dipping method;  
or

3.6.2.4 When the Grease Interceptor is not retaining/capturing FOG so as to comply with the requirements of Chapter 23 and this regulation.

3.6.3 *Inspection.* Grease Interceptors may be inspected by the Inspector as often as necessary in the City's sole discretion to ensure compliance with this Program, including, without limitation, to determine if proper cleaning and maintenance schedules are being adhered to by the FSE. FSEs with Grease Interceptors that are inaccessible to the Inspector are responsible for having staff readily available during any inspection to provide access to and to open and close the Grease Interceptor for the Inspector. It is the sole responsibility of the FSE to provide the City with access to any inaccessible Grease Interceptor.

3.6.4 *Repairs and replacement.* Each FSE shall be responsible for the cost, scheduling, and performance of all repairs and replacements to its Grease Interceptor(s), including, without limitation, any and all repairs and replacements that may be required by the Inspector and/or City Staff under the Program.

- 3.7 **Additives.** The introduction of chemicals, enzymes, emulsifiers, live bacteria or other grease cutters or additives into the wastewater collection system is generally prohibited by the City. On very rare occasions the City may, in its sole discretion, approve an FSE's use of additives. FSEs seeking to introduce additives must, prior to their introduction into Grease Traps or Grease Interceptors, submit the following information to the Department of Utilities and Engineering Wastewater Compliance Section for review and consideration: Material Safety Data Sheets and any other applicable information concerning the composition, frequency of use, and mode of action of the proposed additive(s) and a written statement outlining the FSE's proposed use of the additive(s). The FSE may only use the additives if and when the City grants the FSE permission to do so in writing and then may only do so in accordance with the specific parameters set forth by the City therein. Permission to use any specific additive may be withdrawn by the City at any time, upon the City's providing written notice to the FSE.
- 3.8 **Alternative Grease Removal Devices or Technologies.** The use of alternative Grease removal devices and technologies, such as automatic grease removal systems, are generally prohibited by the City. On rare occasions, the City may, in its sole discretion, approve the use of this technology and these devices on a case-by-case basis. An FSE may only use alternative Grease removal devices or technologies after receiving permission to do so in writing from the City and then may only do so in accordance with the specific parameters set forth by the City therein. Permission to use any alternative Grease removal devices or technologies may be withdrawn by the City at any time, upon the City's providing written notice to the FSE.
- 3.9 **Recordkeeping.** Each FSE shall maintain records required hereunder in a bound logbook kept on site at the FSE describing and documenting all cleaning, maintenance, and repairs performed for each Grease Trap and Grease Interceptor including the date and time of each pump out or cleaning and details regarding same; records documenting and detailing any maintenance and/or repairs, and the dates on which such maintenance and/or repairs were performed and completed; and any other records documenting and related to the cleaning, maintenance, and/or repairs for each Grease Trap or Grease Interceptor. The logbook must be made available by the FSE for review by the Inspector and/or City Staff upon request during an inspection. In addition to the records specified above, each FSE shall also maintain a file on-site which contains the following information:
- 3.9.1 A copy of the FSE's FOG Registration form submitted to the City pursuant to Section 4.0 below; and

3.9.2 Receipts evidencing and identifying (at least by name, address, and service(s) provided) any individuals and/or entities performing cleaning, maintenance, and/or repairs on each Grease Trap and/or Grease Interceptor including, without limitation, Grease pumpers, Grease Haulers, plumbers, and parts suppliers.

Failure to maintain complete records in accordance with the Program as specified herein or to provide such records to the Inspector and/or City Staff upon request constitutes a violation of this regulation. All records required of an FSE under this regulation must be maintained for the time period consisting of the two (2) years immediately preceding the date of the most recent inspection of the FSE by the City, and for any time period thereafter.

3.10 **Disposal.** It is the responsibility of each FSE Owner to ensure that wastes removed from each of its Grease Traps and/or Grease Interceptors are properly disposed of at a facility permitted to receive such wastes.

4.0 **FOG REGISTRATION AND NEW GREASE TRAP/GREASE INTERCEPTOR INSPECTION PROCEDURE**

4.1 **Registration Requirements for FSEs.** Each FSE shall be subject to the FOG Registration requirements in this Section 4.0. This FOG Registration is required in addition to any other permits, registrations, or business license(s) which may be required of the FSE by federal, state, or local law or regulation.

4.2 **Registration Form.** The City shall provide or make available a FOG Registration form for all FSEs located within the City's wastewater service area. All Existing FSEs are required to submit a completed FOG Registration to the City at the address shown on the form no later than thirty (30) calendar days after receiving notification by the City that registration is required. Failure to do so will constitute a violation of this regulation. New FSEs are required to submit a completed FOG Registration to the City at the address shown on the form prior to beginning construction as described in Section 4.5 below. Each FOG Registration form submitted shall include the following information:

4.2.1 FSE Owner's name, title, and contact information; FSE contact name, title, and contact information, if different from the FSE Owner; FSE water and sewer account holder contact information; name of FSE; physical address of FSE; telephone number of FSE; and business mailing address of FSE if different from physical address;

4.2.2 A description of the type of food service activities to be performed at the FSE;

4.2.3 Seating capacity of the FSE;

- 4.2.4 A copy of calculations demonstrating how the size of each Grease Trap and/or Grease Interceptor was determined; a set of plumbing drawings or sketches, including floor plans and riser diagrams; and a site plan showing the location of the sewer discharge(s) and the location of any exterior Grease Interceptors, where applicable (drawings or sketches must have sufficient enough detail to show the location of all kitchen equipment and plumbing fixtures with drains, floor drains, sewer connections, and all Grease Traps and Grease Interceptors);
- 4.2.5 For FSEs with Grease Traps, documentation demonstrating that (a) the Grease Trap is equipped with a device on the inlet side to control the rate of flow through the Grease Trap such that the rate of flow does not exceed the manufacturer's rated capacity in gallons per minute for each Grease Trap; and (b) the Grease Trap is equipped with a sample port on the outlet side;
- 4.2.6 Total hours of operation each day;
- 4.2.7 Executed statement of the FSE Owner certifying that the FSE Owner has received, read, understands, and agrees to abide by *Fats, Oils, and Grease Management – Part 29; Specifications for Grease Traps and Grease Interceptors Regulation - Part 30*; Chapter 23, as well as any other applicable federal, state, and local laws and regulations governing the FSE; that the information provided in the FOG Registration form is accurate; that the FOG Registration form was completed at the FSE Owner's direction and with the FSE Owner's approval; that the FSE Owner understands that providing false information or violating the provisions of the above-stated laws and/or regulations may result in termination of the FSE's water and/or sewer service, and/or revocation of the FSE's permitted water and/or sewer capacity; and that if the FSE's water and/or sewer service is terminated, the FSE will have to submit a new FOG Registration form and/or reapply for water and/or sewer service with the City and bear all associated costs; and
- 4.2.8 All other information regarding the description of the FSE's operations, including, without limitation, information regarding the FSE's Grease Traps and Grease Interceptors, and treatment of same, as identified on the FOG Registration form.

4.3 ***FSEs with Shared Grease Interceptor(s)***. In situations where FSEs share one or more Grease Interceptors, the owner of each Grease Interceptor and any FSE and FSE Owner who utilizes or will utilize the shared Grease

Interceptor are collectively responsible for completion and submission of the FOG Registration form to the City within the time period required in this regulation, for identifying all FSEs connected to each Grease Interceptor in the FOG Registration form, and for ensuring that all FSEs connected to that Grease Interceptor comply with this regulation, as well as Chapter 23. All FSEs connected to the shared Grease Interceptor shall be subject to inspections under this regulation. In the event the identity of an FSE connected to the shared Grease Interceptor changes or in the event that an additional FSE connects to the shared Grease Interceptor, the owner of the shared Grease Interceptor, the FSE Owner, and any FSE utilizing or who will utilize the shared Grease Interceptor must submit an updated FOG Registration form identifying the change or the additional FSE to the City at least thirty (30) calendar days prior to the change and prior to the additional FSE connecting to the shared Grease Interceptor.

#### 4.4 ***New Grease Trap/Grease Interceptor Inspection Procedure.***

4.4.1 *FSE – New Facilities.* After a completed and satisfactory FOG Registration form has been submitted to the City, the FSE may proceed with installation and/or construction of the Grease Trap and/or Grease Interceptor. When installation and/or construction of the Grease Trap and/or Grease Interceptor is completed, the FSE Owner shall notify the City that the FSE is ready for inspection. The FSE Owner shall notify the City prior to covering any exterior Grease Interceptors. During the inspection, the information contained in the FOG Registration form will be verified and the FSE's Grease Traps and/or Grease Interceptors will be inspected. If any Grease Trap or Grease Interceptor requires maintenance or repairs, if any incorrect information has been given, or in the event of noncompliance with any portion of this regulation, the Inspector will issue a written notice requiring that the FSE correct any deficiencies, including a required time schedule for repairs to be effected prior to a second inspection. Second inspections will be performed after a minimum of ten (10) calendar days have elapsed to allow the FSE to implement appropriate and necessary corrective action(s) to correct the deficiencies. If the FSE is not in compliance at the second inspection, the FSE Owner must complete any additional maintenance and/or repairs or take whatever other action may be required for compliance, and resubmit the FOG Registration form. Failure to comply with any portion of this regulation after resubmission of the FOG Registration form may result in enforcement action pursuant to Chapter 23, including, but not limited to, termination or denial of the FSE's water and/or sewer service.



4.4.2 *FSE – Existing Facilities.* All Existing FSEs are required to submit a completed FOG Registration form to the City at the address shown on the form no later than thirty (30) calendar days after receiving notification by the City that registration is required. Failure to do so will constitute a violation of this regulation. A new FOG Registration form must be submitted upon change in ownership of the FSE or changes in operations or plumbing changes or additions, including, without limitation, a change of use which necessitates the issuance of a new SCDHEC food service permit; remodeling or expansion of the food preparation area; and/or modifications to the kitchen waste plumbing system. No new Grease Trap or Grease Interceptor may be placed into service until the City has conducted an inspection pursuant to the procedures set forth in Section 4.5.1 above.

5. ***Inspection Procedure.*** All FSEs are subject to inspection as follows:

5.1 *Inspections.* The Inspector and City Staff may inspect FSEs at any time during business hours in order to verify continued compliance with all applicable laws and regulations, including, without limitation, requirements of this regulation and Chapter 23. All FSEs which have submitted a FOG Registration will be inspected on a regular basis. Inspections shall include, without limitation, all equipment, food processing and storage areas that discharge into the Grease Traps and/or Grease Interceptors at the FSE. The Inspector and/or City Staff shall also inspect the FSE's logbook and other records and data required to be kept hereunder; Grease Trap(s) and/or Grease Interceptor(s); and may check the level of the Grease Trap and/or Grease Interceptor contents and take samples and/or photographs as deemed necessary in the Inspector's sole discretion. If noncompliance is identified by the Inspector and/or City Staff during an inspection, the Inspector will, after the inspection, issue the FSE a written notice of violation directing the FSE to correct any deficiency. The FSE will be scheduled for re-inspection at the time denoted in the notice of violation.

5.2 *Re-inspections.* The Inspector and City Staff will re-inspect FSEs that are issued a notice of violation within the time period specified in the notice of violation. The Inspector shall inspect, without limitation, any repairs made or other corrective measures taken by the FSE with regard to any noted violations and will subsequently provide written notice of compliance or non-compliance to the FSE as the case may be. If, upon re-inspection, the FSE has corrected all of the deficiencies which resulted in the issuance of the notice of violation and the FSE is in full compliance with all other requirements of the Program, the FSE will be notified by the City that it is in compliance.

- 5.3 *Access and Cooperation During Inspections.* Upon the request of the Inspector and other duly authorized employees or agents of the City, each FSE shall allow the Inspector and other duly authorized employees or agents of the City, including, without limitation, City Staff, access to all parts of the FSE premises for inspection, observation, records examination, measurement, sampling, testing and for other purposes in accordance with the provisions of this regulation. The refusal of any FSE to allow the Inspector and/or City Staff entry to or upon the FSE's premises, or an FSE's failure to cooperate in any manner during the course of an inspection, shall constitute an immediate violation of this regulation, which may result in enforcement action pursuant to Section 6.4 of this regulation.
- 5.4 *Non-Compliance:* In the event of continuing non-compliance after re-inspection, the FSE Owner will be notified that continued failure to comply within the time period designated by the City may result in enforcement action pursuant to Chapter 23, including, but not limited to, termination of water and/or sewer service.

6. **VIOLATIONS**

- 6.1 *Notices of Violation.* Deficiencies that will result in a finding of noncompliance and issuance of a notice of violation under this Program include the following:
- 6.1.1 Failure of the FSE to allow the Inspector or City Staff access to all parts of the FSE premises for inspection, observation, records examination, measurement, sampling, testing and for other purposes in accordance with the provisions of this regulation shall constitute an immediate violation;
  - 6.1.2 Failure of the FSE to properly operate, maintain, clean, and/or repair a Grease Interceptor and/or Grease Trap in accordance with this regulation;
  - 6.1.3 Failure of the FSE to report changes in operations or plumbing changes or additions, including, without limitation, a change of use which necessitates the issuance of a new SCDHEC food service permit; remodeling or expansion of the food preparation area; and/or modifications to the kitchen waste plumbing system;
  - 6.1.4 Where the FSE is operating an irreparable or defective Grease Trap and/or Grease Interceptor that is in need of replacement;



- 6.1.5 Failure to report a sale or change in ownership of the FSE by submitting a new FOG Registration form within the thirty (30) days and in accordance with the procedures set forth in this regulation;
- 6.1.6 Failure of the FSE to have or maintain plumbing connections to a Grease Trap or Grease Interceptor in compliance with the requirements of this regulation;
- 6.1.7 Failure of the FSE to submit a completed FOG Registration within thirty (30) days after the date of notification by the City that such an application is required to be submitted;
- 6.1.8 Where the FSE is contributing FOG to the City's wastewater collection system in quantities in excess of the allowable limits as established in Chapter 23;
- 6.1.9 Failure of the FSE to maintain and/or retain, or to produce upon the Inspector or City Staff's request, records as required under this regulation for the time period delineated in this Program;
- 6.1.10 Where the FSE has no Grease management in place;
- 6.1.11 Where the FSE Owner and/or any user of a shared Grease Interceptor has failed to identify to the City all FSEs connected to the shared Grease Interceptor in the FOG Registration form in accordance with the requirements of this regulation;
- 6.1.12 Where the FSE previously received a notice of violation under this Program and, upon re-inspection, the FSE remained in noncompliance;
- 6.1.13 Where the FSE, in the sole discretion of the City, has engaged in bad-faith failure or has refused to comply with a notice of violation issued under this Program or has failed to otherwise cooperate with the Inspector and/or City Staff as required by this regulation; and
- 6.1.14 Any other noncompliance with the Program, this regulation, or Chapter 23.

6.2 *Schedules of Compliance.* Failure to comply with this regulation may result in the following notices of violation with the compliance schedules noted. However, nothing in this Section 6.2 precludes the City from taking

immediate enforcement against an FSE in violation of this regulation or Chapter 23:

6.2.1 A notice of violation may be issued to the FSE by the City with the following compliance schedule in situations where an Inspector determines:

- (a) that the FSE's Grease Trap and/or Grease Interceptor is irreparable or defective and must be replaced.
- (b) that an FSE has no Grease management in place;
- (c) that the FSE has undergone a change of use which necessitates the issuance of a new SCDHEC food service license and/or permit, remodeling, expansion of the food preparation area, or modifications to the kitchen waste plumbing system and has failed to comply with the requirements of Section 3.2 of this regulation;
- (d) that the FSE does not have or does not properly maintain plumbing connections to a Grease Trap or Grease Interceptor in compliance with this regulation.

FSEs receiving a notice of violation for any deficiency identified above will be required, within fifteen (15) days of the date of the notice of violation, to submit a corrective action plan to the City for consideration, outlining and detailing the scope of work, including a timeline for completion, that meets the requirements set forth in this Program, *Specifications for Grease Traps and Grease Interceptors Regulation - Part 30*, and Chapter 23. If the City approves the corrective action plan, the FSE must construct the improvements at its own expense. Construction must be complete within forty-five (45) days of the date of the City's written approval of the corrective action plan. A pre-construction inspection will be scheduled by the City and the FSE is responsible for notifying the City at least twenty-four (24) hours in advance of the start of construction in order that this inspection can be scheduled.

6.2.2 A notice of violation may be issued to the FSE by the City with a fifteen (15) day compliance schedule in situations where an Inspector determines:

- (a) that the FSE has failed to adequately clean, maintain, repair, or replace a Grease Trap or Grease Interceptor as determined by the City in accordance with this Program;

- (b) that the FSE is contributing FOG to the City's wastewater collection system in quantities in excess of the allowable limits as established by the City in Chapter 23;
- (c) that the FSE has been sold or undergoes a change of ownership or in operations and a new FOG Registration form is not submitted by the New FSE Owner in accordance with the requirements of this regulation;
- (d) that the FSE has been notified by the City that it must submit a completed FOG Registration form and the FSE has failed to do so within thirty (30) days of the date of notification;
- (e) that the FSE Owner and/or any user of a shared Grease Interceptor has failed to identify to the City all FSEs connected to the shared Grease Interceptor in the FOG Registration form in accordance with the requirements of this regulation;
- (f) that the FSE has failed to produce, maintain, or retain maintenance logs, files, or other records required to be kept under this regulation for the time period consisting of the two (2) years immediately preceding the date of the most recent inspection at the FSE and any time period thereafter; or
- (g) that the FSE has otherwise failed to comply with the Program in any other manner set forth in this regulation.

6.2.3 A notice of violation will be issued to the FSE by the City with a seven (7) day compliance schedule in situations where an Inspector determines:

- (a) that the FSE previously received a notice of violation under this Program and, upon re-inspection, the FSE remained in noncompliance; or
- (b) that the FSE is, in the sole discretion of the City, has engaged in bad-faith failure or has refused to comply with a notice of violation issued under this Program or has failed to otherwise cooperate with the Inspector and/or City Staff as required by this regulation.

6.3 *Corrective Action.* Where a FSE receives three (3) notices of violation within a one-year time period under this Program, the FSE will be automatically placed on a corrective action plan by the City that is designed to bring the Grease Trap and/or Grease Interceptor into compliance within the period of time specified in the corrective action plan. An FSE may be placed on a corrective action plan for a single violation or combination of violations when, in the discretion of the City, such violation(s) are of a nature or severity which

warrants the imposition of a corrective action plan to bring the FSE into compliance with this regulation.

6.4 *Other Enforcement Action.* Any FSE which violates Chapter 23 or this regulation shall be subject to such other enforcement action as allowed by and in accordance with Chapter 23 and applicable state law, including, but not limited to:

- (a) A civil penalty not to exceed two thousand dollars for each day of violation;
- (b) Termination of water or wastewater service pursuant to Section 23-111 of Chapter 23; and
- (c) Criminal penalties pursuant to Section 23-112 of Chapter 23.

**SPECIFICATIONS FOR  
GREASE TRAPS AND GREASE INTERCEPTORS**

**PART 30**

1. GENERAL

1.1 This section includes guidelines and requirements for design and installing Grease Traps and Grease Interceptors. Construction details GR #1 and GR #2 attached hereto as Attachment A and Attachment B, respectively, are part of these specifications.

1.2 Grease Traps or Grease Interceptors shall be provided by each Food Service Establishment (FSE) for the proper handling of liquid wastes containing significant amounts of fats, oils, and grease as specified in the *Fats, Oils, and Grease Management Regulation* - Part 29 (Part 29). All Grease Traps and Grease Interceptors installed by FSEs must be in compliance with Part 29 and the specifications herein and shall be located so as to be readily and easily accessible for cleaning and inspection. All Grease Traps and Grease Interceptors shall be supplied by and properly cleaned and maintained by the FSE Owner at its own expense in accordance with and as provided in Part 29.

1.3 All FSEs, new or existing, requesting sewer service from the City of Columbia (the City), shall submit a FOG Registration form in accordance with Part 29 prior to receiving sewer service.

1.4 It is the intent of this specification to provide specific standards for the location, design, installation and construction of Grease Traps and Grease Interceptors in accordance with the requirements stated herein. Failure to comply with this specification shall result in the denial or discontinuance of water and/or sewer service.

2. DEFINITIONS

2.1. *Fats, Oils, and Grease (FOG)* means any material, either liquid or solid, composed primarily of fats, oils, and grease from animal or vegetable sources.

2.2. *Food Service Establishment (FSE)* means any commercial facility, including, by way of example and without limitation, restaurants, motels, hotels, cafeterias, hospitals, schools, bars, and any other facility which, in the sole discretion of the City, must install a Grease Trap or Grease Interceptor prior to discharging kitchen or food preparation wastewater into the City's wastewater collection system. This definition includes, but is not limited to, any establishment which is required to have a South Carolina

Department of Health and Environmental Control (SCDHEC) food service license and/or permit.

- 2.3. *FSE Owner or Owner* means, in the case of an individually owned FSE, the Owner(s) and/or proprietor(s) of the FSE. Where the FSE is a franchise operation, the Owner of the franchise is the responsible person and/or entity and is considered the FSE Owner. Where the FSE is owned by a corporation, the corporate representative, as designated on the FOG Registration form, is deemed to be authorized to act on behalf of the corporation. Where two or more FSEs share a common Grease Interceptor, the FSE Owner is any individual and/or entity who owns and/or assumes, maintains, or exercises control of the Grease Interceptor or the property on which the Grease Interceptor is located, as well as any individual and/or entity who utilizes or will utilize the shared Grease Interceptor.
- 2.4. *Gray Water* means all of the liquid contained in a Grease Trap or Grease Interceptor that lies below the floating grease layer and above the bottom solids layer.
- 2.5. *Grease* means a material, either liquid or solid, composed primarily of fats, oils, and grease from animal or vegetable sources. The terms "FOG", "oil and grease," and "oil and grease substances" shall all be included within this definition and may be used interchangeably.
- 2.6. *Grease Interceptor* means a large underground concrete vault located outside of an FSE designed to collect, contain, or remove FOG from the waste stream while allowing the sub-straight or Gray Water to discharge to the wastewater collection system by gravity.
- 2.7. *Grease Trap* means device located within an FSE that is designed to collect, contain, separate, or remove FOG from the waste stream while allowing the sub-straight waste or Gray Water to discharge to the wastewater collection system by gravity.

### 3. DESIGN AND CONSTRUCTION REQUIREMENTS

#### 3.1 NEW FSEs

3.1.1 Non-cooking intensive FSEs, as determined by the City, may be allowed to utilize Grease Traps. Examples of FSEs which might be determined to be non-cooking intensive FSEs are identified in *City of Columbia Grease Trap and Grease Interceptor Tank Sizing Guide (attached hereto as Attachment C)*; however, these FSEs are provided by way of example only. The City will make a determination on the applicable sizing guide formula for an FSE on a case-by-case basis.

3.1.2 All New FSEs (as defined in Section 3.2 of Part 29), with the exception of non-cooking intensive FSEs as determined by the City, are required to install a Grease Interceptor sized in accordance with the *City of Columbia Grease Trap and Grease Interceptor Tank Sizing Guide (Attachment C)*. A Grease Trap or Grease Interceptor must be sized in accordance with the formulae set forth in (A), (B), or (C) of the *City of Columbia Grease Trap and Grease Interceptor Tank Sizing Guide (Attachment C)* unless the City approves sizing calculations signed and sealed by a registered professional engineer in accordance with the Fixture Unit Calculation Method set forth in (D) of the *City of Columbia Grease Trap and Grease Interceptor Tank Sizing Guide (Attachment C)*. No Grease Interceptor less than 1,000 gallons total capacity will be approved for installation by the City unless acceptable engineering calculations sealed by a professional engineer registered in the state of South Carolina and demonstrating that a smaller size has satisfactory capacity are provided by the FSE Owner to the City and are approved by the City. The City retains sole discretion to approve or deny approval of a Grease Interceptor less than 1,000 gallons total capacity in all circumstances, even in the event such engineering calculations are provided.

3.1.3 All New FSEs must submit, for each Grease Trap and Grease Interceptor, cut sheets, plans, and specifications. These documents must be submitted to the City prior to the FSE's installation of the Grease Trap and/or Grease Interceptor. An approval letter for each new Grease Trap or Grease Interceptor must be issued by the City to the FSE prior to construction and/or installation of the Grease Trap and/or Grease Interceptor by the new FSE.

3.1.4 The construction and location criteria for Grease Interceptors must be in accordance with Environmental Protection Agency (EPA) Guidance Document, "On site Wastewater Treatment and Disposal Systems," Chapter 8.

3.1.5 No New FSE will be allowed to initiate operations until proper Grease Traps and/or Grease Interceptors, as appropriate, are installed by the FSE in accordance with this Part 30 and Part 29, and are approved by the City.

3.1.6 For cases in which underground-type Grease Interceptors are appropriate but not feasible to install in the City's sole discretion, new FSEs must install approved Grease Traps in accordance with this Part 30 and Part 29 for use on individual fixtures, including, without limitation, pot sinks, mop sinks, pre-rinse sinks, wok ovens, floor drains and other potentially grease containing drains. In such cases, Grease Traps will be considered acceptable by the City only if approved flow control fittings are placed on the inlet that prevent overloading and a sample port is placed on the outlet of each Grease Trap.

3.1.7 FSE's shall not connect dishwashers, garbage grinders, or domestic sewer to any Grease Trap or Grease Interceptor.

3.1.8 All Grease Traps and Grease Interceptors must be installed by a properly licensed plumbing contractor.

### 3.2 EXISTING FSEs

3.2.1 All existing FSEs (as defined in Section 3.2 of Part 29) must have Grease Traps and Grease Interceptors approved by the City in accordance with Part 29.

3.2.2 In cases where existing FSEs do not already have a Grease Interceptor installed and where the installation of an outdoor Grease Interceptor is feasible in the City's sole discretion, the Grease Interceptor must be installed by the FSE in accordance with this Part 30 and must be approved by the City in writing in advance of installation.

3.2.3 Sizing of any Grease Trap or Grease Interceptor must be in accordance with the *City of Columbia Grease Trap and Interceptor Sizing Guide (attached as Attachment C)*.

3.2.4 Grease Interceptors must be located as close to the source of the wastewater service line at the building as physically possible, while remaining accessible for maintenance.

3.2.5 Existing FSEs shall not connect new dishwashers, garbage grinders, or domestic sewer to any Grease Trap or Grease Interceptor. The City, in its sole discretion, may grant a variance to this requirement in circumstances in which the City determines that compliance with this requirement would be unduly burdensome or impractical due to physical condition or layout of the FSE.

3.2.6 New flow control devices, Grease Traps, or Grease Interceptors must be pre-approved prior to installation.

### 3.3 GREASE TRAPS

3.3.1 Prior to installation, design for all Grease Traps must be submitted by the FSE to the City for approval with supporting calculations, cut sheets, and/or sizing charts, including a sizing chart similar to requirements set forth in the *City of Columbia Grease Trap Specification Sheet Example (attached as Attachment D)*. Satisfactory proof of minimum Grease Trap capacity, as specified in the *City of Columbia Grease Trap and Interceptor Sizing Guide (attached as Attachment C)* must also be provided to the City by the FSE for all Grease Traps prior to installation. A Grease Trap must be sized in accordance with the formulae set forth in (A), (B), or (C) of the *City of Columbia Grease Trap and Grease Interceptor Tank Sizing Guide (Attachment C)* unless the City approves sizing calculations signed and sealed by a registered professional engineer in



accordance with the Fixture Unit Calculation Method set forth in (D) of the *City of Columbia Grease Trap and Grease Interceptor Tank Sizing Guide (Attachment C)*.

### 3.4 GREASE INTERCEPTORS

All FSE's Grease Interceptors must meet each of the following requirements:

3.4.1 A Grease Interceptor must be sized in accordance with the formulae set forth in (A), (B), or (C) of the *City of Columbia Grease Trap and Grease Interceptor Tank Sizing Guide (Attachment C)* unless the City approves sizing calculations signed and sealed by a registered professional engineer in accordance with the Fixture Unit Calculation Method set forth in (D) of the *City of Columbia Grease Trap and Grease Interceptor Tank Sizing Guide (Attachment C)*.

3.4.2 Provide precast or cast in place minimum 4000 psi concrete vaults; The City, in its sole discretion, may allow the use of other materials upon written request for approval prior to installation.

3.4.3 Open top inlet tee must extend to 24" from the bottom of the vault;

3.4.4 The vault shall have a baffle wall with a minimum 3" air gap for venting at the top and an open top tee extending to 12" from the bottom of the vault;

3.4.5 Open top outlet tee must extend to 12" from the bottom of the vault;

3.4.6 Access Manholes shall be provided by the FSE directly above all three tees for inspection and maintenance;

3.4.7 Two-way cleanouts must be provided by the FSEs on the inlet and outlet lines;

3.4.8 Anti-flotation design with proper base course and compacted sub-grade should be considered to prevent settling where conditions warrant;

3.4.9 The FSE must design vault top and manhole covers for HS-20 rated loading where applicable; and

3.4.10 All Grease Interceptors shall be located where they are easily accessible for inspection, cleaning, and maintenance.

### 3.5 STANDARD GREASE INTERCEPTOR DETAILS

3.5.1 FSEs must comply with standard details GR #1 (Attachment A) and GR #2 (Attachment B) for standard Grease Interceptor installation.

3.5.2 Grease Interceptors may be installed in series if volume required is more than 1500 gallons. When installed in series, the first tank shall not have a baffle or center tee (see standard detail GR #2, Attachment B).

3.6 ACCESS MANHOLES

3.6.1 The minimum access opening dimensions shall be a minimum of 24" in diameter.

3.6.2 An access opening shall be provided by the FSE above the inlet, baffle wall, and outlet tees and shall be easily removable by one person.

3.6.3 A minimum 6" diameter traffic rated clean out with a concrete collar extending down through the vault top may be provided by the FSE above the baffle wall tee in lieu of an access manhole.

3.6.4 Manhole Frame and Cover requirements:

- 3.6.4.1 Provide grey iron castings, ASTM A48, Class 30 Iron;
- 3.6.4.2 Machine all bearing surfaces;
- 3.6.4.3 Acceptable manufacturer: US Foundry Model 680; and
- 3.6.4.4 Provide HS-20 rated frame and cover where applicable.

4. INSPECTION FOR ACCEPTANCE

4.1 The FSE must notify the City 48 hours in advance, during the normal work week, when the Grease Interceptor is ready for final inspection by the City and the City must give final approval prior to the FSE covering any Grease Interceptor.

4.2 Where the City denies approval of the Grease Trap and/or Grease Interceptor is denied for a new FSE, the City may elect to submit a request to the appropriate building official requesting that certificates of occupancy be withheld until the Grease Trap and/or Grease Interceptor is constructed in accordance with this specification and is approved by the City.

## Attachment A

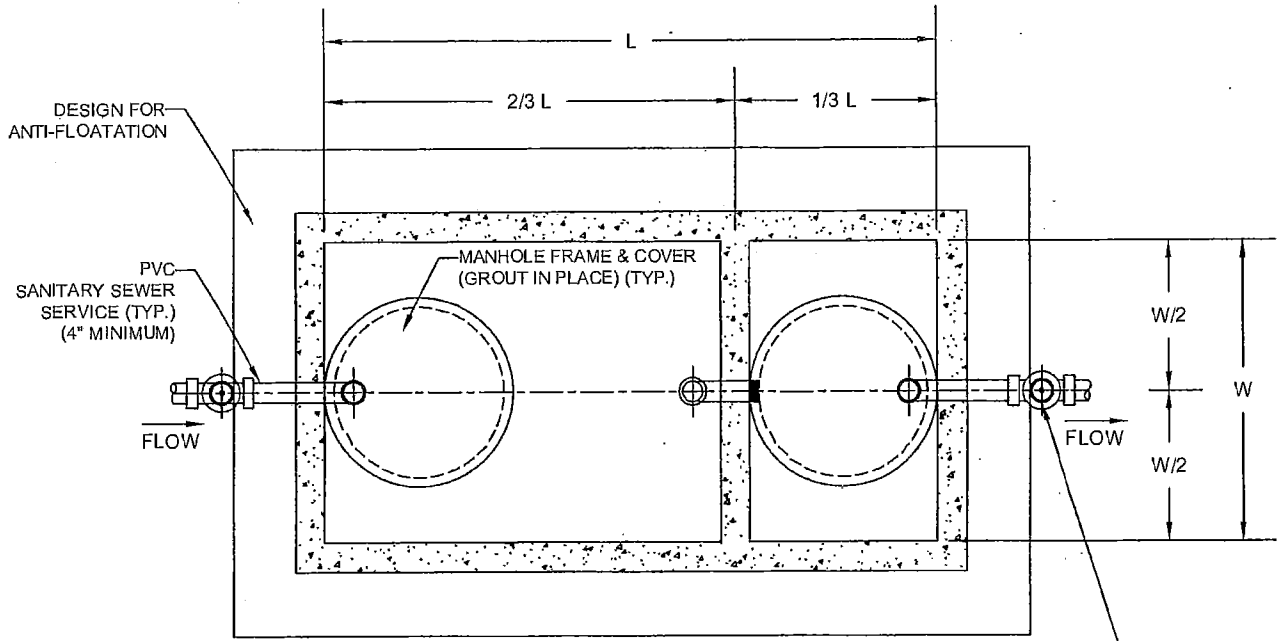

**PLAN**

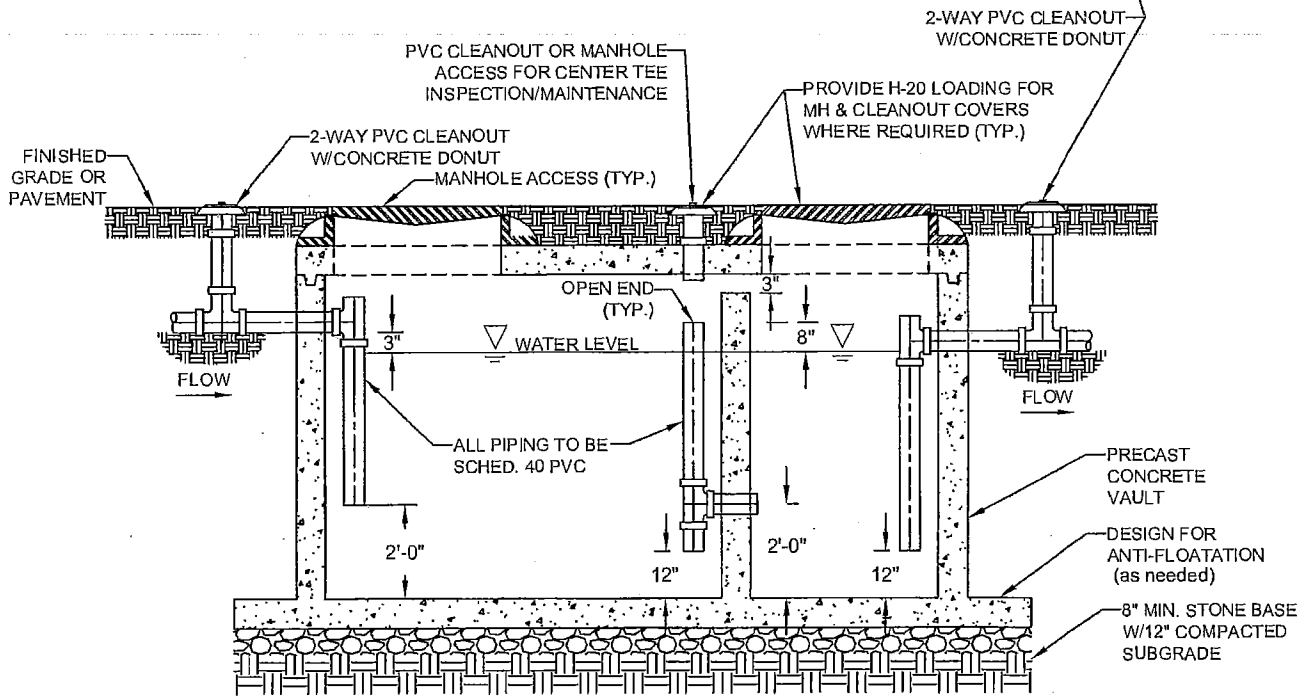

**PROFILE**

**NOTES:**

1. ALL PROPOSED GREASE INTERCEPTORS TO BE SUBMITTED TO CITY OF COLUMBIA FOR APPROVAL PRIOR TO INSTALLATION.

**GR #1**

### CITY OF COLUMBIA STANDARD GREASE INTERCEPTOR

(NOT TO SCALE)

2. ALL GREASE INTERCEPTORS TO BE INSTALLED, OWNED AND MAINTAINED BY PROPERTY OWNER.
3. USE NON-SHRINK GROUT AT ALL PENETRATIONS.
4. PROVIDE BUTYL RUBBER SEAL BETWEEN ALL SECTIONS AND TOP.
5. LOCATE MANHOLE ACCESS ABOVE TEES FOR VISUAL INSPECTION AND MAINTENANCE.

### Attachment B

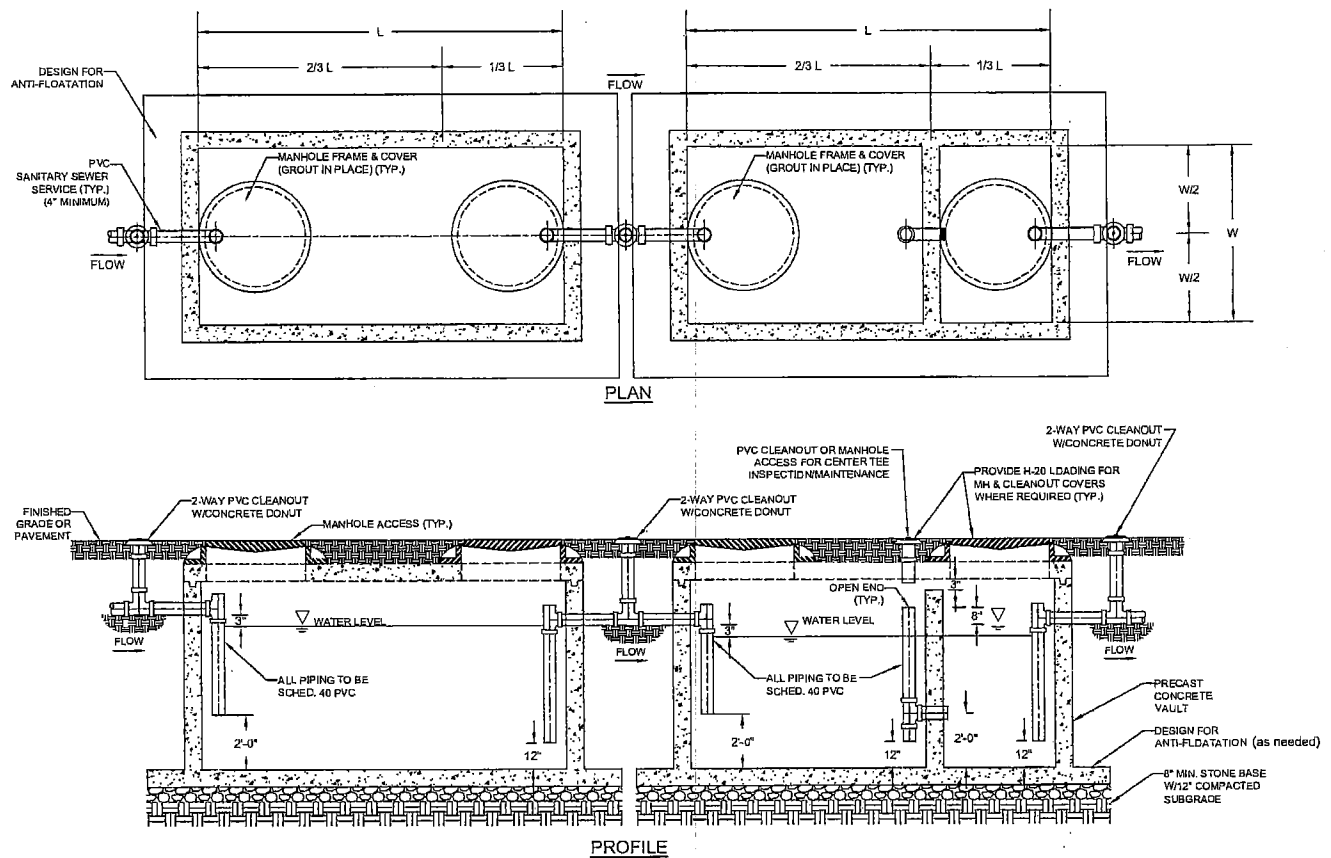

GR #2

CITY OF COLUMBIA  
 STANDARD GREASE INTERCEPTOR IN SERIES  
 (NOT TO SCALE)

**NOTES:**

1. ALL PROPOSED GREASE INTERCEPTORS TO BE SUBMITTED TO THE CITY OF COLUMBIA FOR APPROVAL PRIOR TO INSTALLATION.
2. ALL GREASE INTERCEPTORS TO BE INSTALLED, OWNED AND MAINTAINED BY PROPERTY OWNER.
3. USE NON-SHRINK GROUT AT ALL PENETRATIONS.
4. PROVIDE BUTYL RUBBER SEAL BETWEEN ALL SECTIONS AND TOP.
5. LOCATE MANHOLE ACCESS ABOVE TEES FOR VISUAL INSPECTION AND MAINTENANCE.

## Attachment C

## CITY OF COLUMBIA

### GREASE TRAP AND GREASE INTERCEPTOR SIZING GUIDE

- A. **NON-COOKING INTENSIVE FOOD SERVICE ESTABLISHMENTS** (examples include ice cream shops, candy shops, deli in grocery or convenience store without cooking facilities, bagel shops, etc.)

**Formula:** Min. Trap Capacity = [(# of compartments x Length x Width x Depth)/1728] x 7.48 x 0.80

Example: 3 compartment sink = [(3 compartments x 17" (L) x 17" (W) x 11" deep)/1728] x 7.48 x 0.80  
= 33.02 gallon trap capacity (4.4 cu. ft.).

- B. **COOKING INTENSIVE FOOD SERVICE ESTABLISHMENTS** (examples include restaurants, drive-in restaurants, deli's with cooking capacity, carry out restaurants, catering, delivery, etc.)

**Formula:** Min. Interceptor Volume = No. of Seats x FR x (Hours of Operation/18)

FR= Flow Rate

Full Service Restaurant = 25 gallons

Non-Washable, Paper, or Plastic Utensils = 12.5 gallons

- C. **OTHER FOOD SERVICE ESTABLISHMENTS** (examples include hotels, nursing homes, schools, office, or factory cafeteria, etc.)

**Formula:** Total Volume = # of person meals x 5 gal. x DW

# of person meals = number of meals served during either breakfast, lunch, or supper, whichever is greatest

DW=Dishwashing: With Dishwasher = 1.0 or Without Dishwasher = .75

Examples: 1. A cafeteria with a dishwasher serves 300 meals a day = 300 meals x 5 gal. x 1.0 = 1,500 gal.  
2. 200 unit motel w/efficiency kitchens = 200 rooms x 4 people/room x 5 gal./meal x 0.75 = 3,000 gal.

- D. **FIXTURE UNIT CALCULATION METHOD** (When using the fixture unit calculation method, the Owner must submit calculations signed and sealed by a registered professional engineer in the state of South Carolina to the City for review.)

**Formula:** Total Volume = Q x T x SF

Q = Flow in GPM – Flow derived from total Drainage Fixture Units (DFU) or Fixture Units (FU) connected to the interceptor as determined using the International Plumbing Code (2000 or higher edition) or AWWA Manual of Water Supply Practices M22.

T = Retention Time – 30 Minutes

SF = Storage Factor = 1.25 based on fully loaded interceptor with 25% grease/solids.

**NOTES:**

1. Non-Cooking Intensive Food Service Establishments as determined by the City may utilize grease traps (must have provisions for sampling at outlet of trap). All others must utilize grease interceptors unless approved by City staff. Refer to *Specifications for Grease Traps and Interceptors – Part 30* of the City of Columbia Standard Specifications for requirements.
2. Regardless of minimum size required, underground grease interceptors are required to have a minimum 1,000 gallon capacity. When greater than 1,500 gallon capacity is required, multiple units may be furnished and installed in series, see standard details in "Specifications for Grease Traps and Interceptors – Part 30 of the City of Columbia Standard Specifications. Larger sized interceptors may be approved on a case by case basis.
3. Refer to *Fats, Oils, and Grease Management Regulation – Part 29* for additional information.
4. The foregoing is a recommended minimum guideline only. It does not in any way relieve the owner of ordinance mandated requirements that discharged waste have a maximum grease content of 100 mg/l, see Sewer Use Ordinance Sec. 23-102.
5. Contact Scott Rogers at 545-3290 for more information.

Attachment D

**CITY OF COLUMBIA  
GREASE TRAP  
SPECIFICATION SHEET EXAMPLE**

**\*\*NON-COOKING INTENSIVE FOOD ESTABLISHMENTS ONLY\*\***

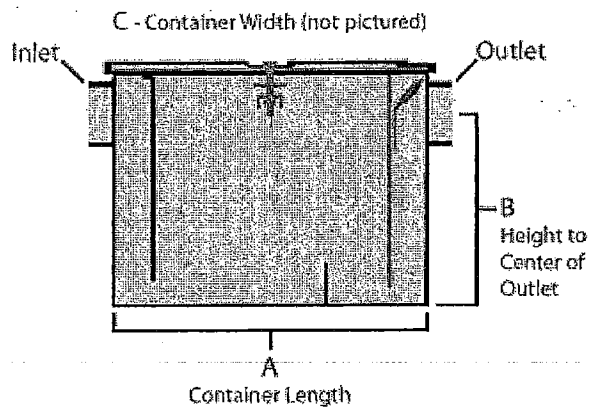

(NOT TO SCALE)

| Total<br>Gallon<br>Capacity | Dimension In Inches |               |              |
|-----------------------------|---------------------|---------------|--------------|
|                             | Length<br>(A)       | Height<br>(B) | Width<br>(C) |
| 9.2                         | 19"                 | 8"            | 14"          |
| 19.4                        | 24"                 | 11"           | 17"          |
| 49.8                        | 30"                 | 16"           | 24"          |
| 74.2                        | 34"                 | 18"           | 28"          |
| 98.7                        | 38"                 | 20"           | 30"          |

**Formula for Calculating Total Grease Trap Capacity:**

$$[\text{Length(A)} \times \text{Height(B)} \times \text{Width(C)} / 1728] \times 7.48 = \text{Total Gallon Capacity}$$

**NOTES:**

1. ALL PROPOSED GREASE TRAP PLANS TO BE SUBMITTED & APPROVED BY CITY OF COLUMBIA DEPARTMENT OF UTILITIES AND ENGINEERING PRIOR TO INSTALLATION.
2. GREASE TRAP INSTALLED, OWNED AND MAINTAINED BY PROPERTY OWNER.

CITY OF COLUMBIA  
STANDARD OPERATING PROCEDURES FOR GREASE FACILITY INSPECTIONS

1.0 General

- 1.1 In accordance with the City of Columbia Code of Ordinances, Chapter 23, Wastewater Services, in conjunction with Utilities and Engineering's Regulations Part 29 and Part 30, discharge of water or wastes containing excessive grease into the sanitary sewer system is prohibited. Compliance with this Ordinance and these regulations is monitored through periodic grease trap/interceptor and sewer inspections at Food Service Establishments ("FSEs") (as defined in Regulations Part 29 and Part 30) that generate wastes containing grease. Frequency of inspection is established based on historical data.

The City tracks the effectiveness of its FOG program through various performance measures which, in the City's sole discretion, may be altered or changed from time to time. The City is currently tracking the number of FOG-related sanitary sewer overflows ("SSOs") in comparison with the City's total SSOs. The City is also regularly engaged in public education efforts in order to decrease FOG-related SSOs, including through enclosure of flyers in water bills and distribution of door knockers by inspectors in neighborhoods regarding the City of Columbia FOG Program.

Wastewater Maintenance Division ("WWM") personnel are kept up-to-date on which area each inspector covers. Inspectors will be notified if WWM field personnel are having substantial or noteworthy FOG issues in their area.

1.2 Training

1.2.1 New inspectors are trained upon hire. The City of Columbia Code of Ordinances, Chapter 23, Regulations Parts 29 and 30, and the Standard Operating Procedures for Grease Facility Inspections are provided to and reviewed with each new inspector, and receipt and review are documented. New inspectors are also introduced to the City's WWM personnel. On-the-job training is conducted for all new inspectors by an existing trained inspector for a minimum of one week before the new inspector is permitted to individually conduct inspections. During this initial training period, new inspectors are given practical training regarding all aspects of the Standard Operating Procedures for Grease Facility Inspections, including inspection protocol. New inspectors are also trained in safety and hygiene related to inspections, discussed in Section 2.0, below. The determination of when a new inspector is adequately trained to conduct inspections on his or her own will be made in the discretion of the existing trained inspector conducting the training.

1.2.2 Existing inspectors are regularly issued any updates to the Standard Operating Procedures upon final revision and are trained on current Standard Operating Procedures.

1.2.3 All inspectors are encouraged to attend workshops, conferences and tradeshows to further their knowledge in this field and stay up-to-date with emerging technology and techniques.

## 2.0 Safety and Hygiene

2.1 Prior to conducting sanitary sewer inspections in connection with FSE inspections, the inspector will receive training concerning the associated hazards. The inspector will review, with his/her supervisor, the hazard assessment for the task. The inspector will be required to understand the hazards and demonstrate knowledge of the necessary safety precautions, procedures and equipment.

2.2 Sanitary sewer inspections are frequently conducted at manholes in, or adjacent to, roadways. For inspections requiring temporary traffic control the inspector will follow procedures in the South Carolina Work Zone Safety Guidelines and the South Carolina Manual On Uniform Traffic Control Devices, Part V, "Traffic Control for Highway Construction and Maintenance Operations". Traffic control may necessitate assistance from additional personnel.

## 3.0 Inspection Procedures

3.1 Inspection procedures for New FSEs will be conducted as follows:

3.1.1 After a completed and satisfactory FOG Registration form has been submitted to the City, the FSE may proceed with installation and/or construction of the Grease Trap and/or Grease Interceptor. When installation and/or construction of the Grease Trap and/or Grease Interceptor is completed, the FSE Owner (as defined by Regulation Part 29) shall notify the City that the FSE is ready for inspection. The FSE Owner shall notify the City prior to covering any exterior Grease Interceptors. During the inspection, the information contained in the FOG Registration form will be verified and the FSE's Grease Traps and/or Grease Interceptors will be inspected. If a grease trap or grease interceptor approved by the City Engineer (and/or his or her designee) is properly installed and functioning, the FSE will be deemed to be in compliance and a follow up letter, Prerecorded Letter 4 (PR4) (Exhibit G), will be sent to the FSE Owner. If any Grease Trap or Grease Interceptor requires maintenance or repairs, if any incorrect information has been given, or in the event of noncompliance with any portion of this regulation, the inspector will issue a written notice requiring that the FSE correct any deficiencies, including a required time schedule for repairs to be effected prior to a second inspection. Second inspections will be performed after a minimum of ten (10) calendar days have elapsed to allow the FSE to



implement appropriate and necessary corrective action(s) to correct the deficiencies. If the FSE is not in compliance at the second inspection, the FSE Owner must complete any additional maintenance and/or repairs or take whatever other action may be required for compliance and resubmit the FOG Registration form.

3.2 Inspection of Existing FSEs will be conducted as follows:

3.2.1 Drawings are reviewed to identify FSE sewer connections and upstream and downstream manholes.

3.2.2 Each FSE shall be solely responsible for the cost of grease trap/grease interceptor installation, inspection, cleaning and maintenance. FSEs with grease traps may contract with a grease hauler cleaning service or they may develop a written protocol and perform their own grease trap cleaning and maintenance procedures. Facilities with interceptors shall utilize a grease hauler to properly dispose of interceptor contents. Cleaning and maintenance of grease traps and interceptors must be performed in accordance with Part 29 and the manufacturer's operation and maintenance recommendations and instructions. In the event of conflict between Part 29 and the manufacturer's operation and maintenance recommendations and instructions, Part 29 will control. The FSE owner must have a copy of this documentation and maintenance logs demonstrating compliance on site and must be able to produce them immediately upon the request of the inspector.

3.2.3 Cleaning frequency for grease traps and grease interceptors is to be conducted as follows.

- (a) Grease traps must be cleaned as often as necessary to achieve compliance with the City of Columbia Code of Ordinances, Chapter 23, and Part 29. This cleaning frequency may, in some cases, exceed that recommended by the manufacturer. The City requires the complete removal of all floating materials, gray water and bottom solids. The return of gray water back into the grease trap or the wastewater collection system is NOT allowed. Grease trap cleaning may include removing/scraping excessive solids from walls, floors, baffles and inlet and outlet piping. It shall be the responsibility of each FSE to inspect its grease trap during the cleaning procedure to ensure that the trap is properly cleaned out and that all fittings and fixtures inside the trap are in working condition and are functioning properly.
- (b) Grease interceptors must be cleaned at a minimum frequency of twice per year. The City requires the complete removal of all floating materials, gray water and bottom solids. The return of gray water back into grease interceptor or the wastewater collection system is NOT allowed. Grease interceptor cleaning shall be performed as often as necessary and in a manner necessary to achieve compliance with the City of Columbia Code of

Ordinances, Chapter 23, and Part 29. This cleaning frequency may, in some cases, exceed that recommended by the manufacturer. Such cleaning may include removing/scraping and/or hydro scrubbing excessive solids from walls, floors, baffles and all interior plumbing. It shall be the responsibility of each FSE to inspect its grease interceptor during the cleaning procedure to ensure that the interceptor is properly cleaned out and that all fittings and fixtures inside the interceptor are in working condition and are functioning properly. In addition to the required cleaning, each FSE shall determine an additional frequency at which its grease interceptor(s) must be cleaned for proper operation as necessary to satisfy each of the following criteria:

- 1) The floatable grease layer shall not exceed six inches in depth as measured with an approved dipping method.
- 2) The settleable solids layer shall not exceed six inches in depth as measured with an approved dipping method.
- 3) The total volume of captured grease and solid material shall not displace more than 25% of the capacity of the interceptor as calculated with an approved dipping method.
- 4) The interceptor shall retain/capture FOG such that the discharge of FOG is less than 100mg/l, or as otherwise specified in the City of Columbia Code of Ordinances, Chapter 23 and/or in Part 29. (When the FSE is not in compliance in this regard, the inspector may require, in his sole discretion, testing and submission of results to the inspector, at the FSE's own expense.)

3.2.4 Upon entering the FSE, the inspector should present his/her City identification and request to speak to the person in charge. Information concerning the FSE should be recorded by the inspector on a Grease Trap and Grease Interceptor Survey (Exhibit A).

3.2.5 The FSE's grease traps and/or grease interceptors, including clean-outs, manholes, and inlet and outlet tees, will be inspected by the inspector. If the FSE has a grease trap, FSE staff will be asked by the inspector to open and close the trap. In no case shall the inspector open or close a trap. During inspections, arrangements must be made by the FSE to have a qualified staff member open and close the trap. Findings will be noted by the inspector on the Grease Trap and Grease Interceptor Survey (Exhibit A). When appropriate, photographs should be taken by the inspector to document excessive grease discharge.

3.2.6 An FSE's grease removal maintenance records will be reviewed by the inspector to confirm that the FSE is taking appropriate and required steps to keep grease out of the sanitary sewer system. Grease Trap and Grease Interceptor Operation and Maintenance Program Form (Exhibit B) may be used by the FSE if they do not already have maintenance documentation (these records must be maintained and retained for at least two (2) years immediately preceding the date

of the most recent inspection) at the FSE. A City of Columbia FOG (Fats, Oils and Grease) Brochure (Exhibit C) is also provided to the FSE upon inspection. This brochure is educational in purpose and covers best management practices for grease removal.

3.2.7 If the inspector encounters disrepair or lack of maintenance when inspecting a grease trap and/or grease interceptor, at a minimum, the downstream manhole must be checked by the inspector for FOG accumulation. If excessive FOG is found in the downstream manhole, the inspector must notify wastewater maintenance who will clean and inspect the line.

#### 4.0 Violations

4.1 If noncompliance is identified during an inspection, the inspector may initiate an enforcement action pursuant to City in the City of Columbia Code of Ordinances, Chapter 23 and Regulation Part 29 and/or issue the FSE a written notice of violation directing the FSE to correct any deficiency. The notice of violation will include a schedule for compliance and re-inspection as follows:

4.1.1 A notice of violation may be issued to the FSE by the City with the following compliance schedule in situations where an inspector determines:

- (a) that the FSE's Grease Trap and/or Grease Interceptor is irreparable or defective and must be replaced.
- (b) that a FSE has no Grease management in place;
- (c) that the FSE has undergone a change of use which necessitates the issuance of a new SCDHEC food service license and/or permit, remodeling, expansion of the food preparation area, or modifications to the kitchen waste plumbing system and has failed to comply with Section 3.2 of Regulation Part 29;
- (d) that the FSE does not have or does not properly maintain plumbing connections to a Grease Trap or Grease Interceptor in compliance with Regulation Part 29.

Prerecorded Letter 2 (PR2) (Exhibit E) will be mailed after an inspection identifying these deficiencies. FSEs receiving a notice of violation for any deficiency identified above will be required, within fifteen (15) days of the date of the notice of violation, to submit a corrective action plan to the City for consideration, outlining and detailing the scope of work, including a timeline for completion, that meets the requirements set forth in this Program, Specifications for Grease Traps and Grease Interceptors Regulation - Part 30, and Chapter 23. If the City approves the corrective action plan, the FSE must construct the improvements at its own expense. Construction must be complete within forty-five (45) days of the date of the City's written approval of the corrective action plan. A pre-construction inspection will be scheduled by the City and the FSE is responsible for notifying the

City at least twenty-four (24) hours in advance of the start of construction in order that this inspection can be scheduled.

4.1.2 A notice of violation may be issued to the FSE by the City with a fifteen (15) day compliance schedule in situations where an inspector determines:

- (a) that the FSE has failed to adequately clean, maintain, repair, or replace a Grease Trap or Grease Interceptor as determined by the City in accordance with this Program;
- (b) that the FSE is contributing FOG to the City's wastewater collection system in quantities in excess of the allowable limits as established by the City in Chapter 23;
- (c) that the FSE has been sold or undergoes a change of ownership or in operations and a new FOG Registration form is not submitted by the New FSE Owner in accordance with the requirements of this regulation;
- (d) that the FSE has been notified by the City that it must submit a completed FOG Registration form and the FSE has failed to do so within thirty (30) days of the date of notification;
- (e) that the FSE Owner and/or any user of a shared Grease Interceptor has failed to identify to the City all FSEs connected to the shared Grease Interceptor in the FOG Registration form in accordance with the requirements of this regulation;
- (f) that the FSE has failed to produce, maintain, or retain maintenance logs, files, or other records required to be kept under this regulation for the time period consisting of the two (2) years immediately preceding the date of the most recent inspection at the FSE and any time period thereafter; or
- (g) that the FSE has otherwise failed to comply with the Program in any other manner set forth in this regulation.

Prerecorded Letter 1 (PR1) (Exhibit D) will be mailed after an inspection identifying these deficiencies, and a follow-up inspection will be conducted within approximately 15 days of the date reflected on the PR2 Letter.

4.1.3 If on the follow-up inspection, the FSE can demonstrate through visual inspection and maintenance records compliance with the City of Columbia Code of Ordinances, Chapter 23, and Part 29, the FSE is deemed to be in compliance and a follow-up letter, Prerecorded Letter 3 (PR3) (Exhibit F), will be sent to the FSE Owner.

4.1.4 If any follow-up inspection reveals a continuation of discharge containing excessive grease or insufficient remedial action by the FSE, the investigator will contact the FSE Owner by phone. Depending on the nature of the situation, and in the City's sole discretion, the FSE may be granted an extension to achieve compliance in the City's sole discretion. In cases where FSEs make no attempt to correct the problem, or in other circumstances warranting such action, Prerecorded

Letter 5 (PR5) (Exhibit H) will be hand-delivered to the FSE Owner. The Director of Utilities and Engineering will be copied on this letter and, in the case of continued noncompliance after re-inspection, the inspector will notify the wastewater compliance manager who, in turn, will refer the continuing noncompliance to the Legal Department for an enforcement action pursuant to the City of Columbia Code of Ordinances, Chapter 23, and Part 29. The referral may include a recommendation to terminate the FSE's water or wastewater service pursuant to Section 23-111 of Chapter 23.

5.0 Records

- 5.1 It is extremely important that the inspector maintain thorough and accurate records, including, without limitation, notes on verbal communications, throughout the investigatory and remediation process. Photographs should be clearly labeled and filed with other documentation.

**INDEX OF EXHIBITS TO CITY OF COLUMBIA  
STANDARD OPERATING PROCEDURES FOR  
GREASE FACILITY INSPECTIONS**

- Exhibit A:** Grease Trap and Grease Interceptor Survey
- Exhibit B:** Grease Trap and Grease Interceptor Operation and Maintenance Program Form
- Exhibit C:** City of Columbia FOG (Fats, Oils and Grease) Brochure
- Exhibit D:** Prerecorded Letter 1 (PR1)
- Exhibit E:** Prerecorded Letter 2 (PR2)
- Exhibit F:** Prerecorded Letter 3 (PR3)
- Exhibit G:** Prerecorded Letter 4 (PR4)
- Exhibit H:** Prerecorded Letter 5 (PR5)

## EXHIBIT A Grease Trap and Grease Interceptor Survey

INSPECTION DATE: \_\_\_\_\_ INSPECTOR NAME: \_\_\_\_\_

NAME OF FACILITY: \_\_\_\_\_

ADDRESS (STREET #, NAME, TYPE & ZIP): \_\_\_\_\_

FACILITY PHONE #: \_\_\_\_\_

FACILITY CONTACT PERSON (MANAGER): \_\_\_\_\_

GREASE TRAP DEVICE AVAILABLE: YES \_\_\_\_\_ NO \_\_\_\_\_

TRAP SIZE: \_\_\_\_\_ LOCATION: \_\_\_\_\_ HAULER USED: \_\_\_\_\_ # OF LIDS: \_\_\_\_\_ LAST PUMP DATE: \_\_\_\_\_

TRAP SIZE: \_\_\_\_\_ LOCATION: \_\_\_\_\_ HAULER USED: \_\_\_\_\_ # OF LIDS: \_\_\_\_\_ LAST PUMP DATE: \_\_\_\_\_

PUMP OUT FREQUENCY ON SCHEDULE? Y N HOW OFTEN ARE TRAP(S) CLEANED? \_\_\_\_\_

MAINTENANCE LOG MAINTAINED? Y N WILL IN FUTURE FURNISHED

PASS OR FAIL INSPECTION? \_\_\_\_\_ IF FAIL - TYPE OF ENFORCEMENT ACTION: \_\_\_\_\_ DATE MAILED: \_\_\_\_\_

IF NO TRAP

|  |                                |                              |
|--|--------------------------------|------------------------------|
| HOURS OF OPERATION: _____                                  | SEAT COUNT: _____              | FULL SERVICE OR NONWASHABLES |
| SINK MEASUREMENTS: _____                                   | UNDER SINK MEASUREMENTS: _____ |                              |
| COPY OF MENU NEEDED <input type="checkbox"/> MENU ATTACHED |                                |                              |

FACILITY REPRESENTATIVE SIGNATURE: \_\_\_\_\_

FACILITY OWNER E-MAIL: \_\_\_\_\_

ADDITIONAL COMMENTS:  
\_\_\_\_\_  
\_\_\_\_\_

# EXHIBIT B Grease Trap and Grease Interceptor Operation and Maintenance Program

Note: You may use this form to assist in documenting maintenance of grease traps and/or grease interceptors both inside and outside of the building. Proper maintenance can help reduce stoppages on private property and in the City's sewage collection system.

**Company Information**

Company Name: \_\_\_\_\_ Site Address: \_\_\_\_\_

Company Contact: \_\_\_\_\_

| Date | Maintenance Performed<br>List: Cleaned, Pumped, Repaired, etc. | Total Quantity in<br>Gallons Removed | Cleaning, Pumping, Maintenance,<br>or Repair Performed By | Signature of<br>Inspector |
|------|--|--------------------------------------|---|---------------------------|
|      |  |                                      |   |                           |
|      |  |                                      |   |                           |
|      |  |                                      |   |                           |
|      |  |                                      |   |                           |
|      |  |                                      |   |                           |
|      |  |                                      |   |                           |
|      |  |                                      |   |                           |
|      |  |                                      |   |                           |
|      |  |                                      |   |                           |
|      |  |                                      |   |                           |
|      |  |                                      |   |                           |
|      |  |                                      |   |                           |
|      |  |                                      |   |                           |
|      |  |                                      |   |                           |
|      |  |                                      |   |                           |
|      |  |                                      |   |                           |
|      |  |                                      |   |                           |
|      |  |                                      |   |                           |
|      |  |                                      |   |                           |
|      |  |                                      |   |                           |
|      |  |                                      |   |                           |
|      |  |                                      |   |                           |
|      |  |                                      |   |                           |
|      |  |                                      |   |                           |
|      |  |                                      |   |                           |
|      |  |                                      |   |                           |
|      |  |                                      |   |                           |
|      |  |                                      |   |                           |
|      |  |                                      |   |                           |
|      |  |                                      |   |                           |
|      |  |                                      |   |                           |
|      |  |                                      |   |                           |
|      |  |                                      |   |                           |
|      |  |                                      |   |                           |
|      |  |                                      |   |                           |
|      |  |                                      |   |                           |



**EXHIBIT C**

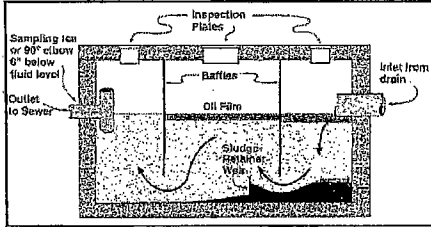

3. Measure oil floating on top of the water. When there are two inches or more of oil in any chamber, it should be removed. Older oil has a chance of becoming emulsified (broken up into smaller droplets).

**Who do I call to clean it out?**

The yellow pages will list companies that pump out and clean oil and water separators. These firms have special vacuum trucks that pump out materials with the consistency of anything from liquid slurry to solid dirt. The bulk liquid is shipped to a licensed treatment facility where the oils, solids and heavy metals are separated from the water. The treated water can be discharged to the sewer. You should never use a septic tank service to clean your oil and water separator or catch basin. Since vendors may have different requirements and/or treatment methods, costs could vary. Fees can include:

- Lab analysis of a sample of the separator's contents
- Wastewater disposal charges
- Surcharge for excessive oil and sludge
- Truck time, figured portal to portal, with a 2-4 hour minimum
- Tank truck rinse out at the treatment facility

**What should not go through a separator?**

Antifreeze, degreasers, and detergents will emulsify (break up) oil into small droplets so the oil doesn't float to the surface. This will allow these pollutants to drain into the sewer system.

Fuels, alcohols or solvents not only can emulsify oil, but accumulated vapors can pose a threat to line workers at the pump stations or treatment plant.

Concentrated amounts of city products can overload the baffles or plates and pass through to the sewer.

Floating oils that are not skimmed from the surface of the separator will eventually become emulsified and appear to have a lighter color.

Heavy metal-bearing wastewater such as hot tank and cabinet washer solutions from auto repair or machine shops, any metal finishing, plating, or metal recovery water, and water-soluble machine coolant should not go through a separator also.

**What can I do to maintain my oil and water separator?**

You can save maintenance costs by diverting oils and sludge out of your separator. The sooner oils are removed, the less chance they will have to become emulsified. Oils that are free-floating can be carefully vacuumed off with a wet/dry vacuum. This oil should be

stored in a separate drum and properly disposed of. Cleaners may contain certain chemicals that, when mixed with the oil, could make them a hazardous waste.

Another way to remove oil is to use absorbent pads or socks. These float on top of the water and attract only oil. They can be placed in the inlet chamber to trap oil before it gets a chance to migrate. Pads should be checked often so they don't get saturated. Pads can be wrung out and reused if handled properly and are available at most chemical and safety supply stores.

Sludge is caked on grease and oil dirt that builds up on the bottom of the separator. It is expensive to dispose of and difficult to clean out. A catch basin, installed before the separator will trap sludge before it washes into the separator. The sludge can then be shoveled out. This can be very helpful to businesses cleaning muddy equipment.

**Grease Rendering & Recycling:**

Rendering companies or "grease recyclers" will accept oil, grease, and other animal by-products, including deep fry fat and bones, thereby turning a nuisance waste material into a beneficial product such as animal feeds. There are many benefits to this approach. They are listed below.

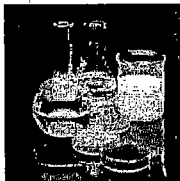

1. Compliance - Rendering prevents grease from reaching the City sewer system and thereby helps restaurants maintain compliance.
2. Cost Avoidance - The charge for pumping out a grease trap is considerably more than the service fee charged by a renderer.
3. Economic Incentives - Renderers' service fees are low and often provided at no charge. In some cases, rendering companies are willing to pay for restaurant oil and grease.
4. Environmental Savings - Natural resources and energy are conserved through source reduction and recycling. FOG recycling keeps these materials from clogging the City sewer lines, as well as from using valuable landfill space.

**The following Grease Haulers and Recyclers are Approved to Dispose Directly at City of Columbia's Septage Receiving Station:**  
(location noted if not in Columbia, SC)

- |  |                                       |
|--|---------------------------------------|
| * Ameriguard Maintenance Service, LLC (Freshe, CA) | * G & K Tank Service (Sumter, SC)     |
| * Apple Plumbing                                   | * Genie Love Contracting              |
| * AWS (Cayce, SC)                                  | * Lucas Septic Tank & Utility Service |
| * C.E. Taylor and Son, Inc.                        | * Mao Service & Pumping               |
| * C. Walker Septic Tank Service (Ridgeway, SC)     | * Moyer Construction                  |
| * Commercial Waste Management, Inc (Allarka, GA)   | * PASCOM, LLC                         |
| * Connor Plumbing (Martinez, GA)                   | * Providence Environmental, Inc       |
| * Daussy By-products (St. George, SC)              | * Sharp's Plumbing Service, Inc       |
| * Dreher Septic Service                            | * Sisk's Septic Tank & Pumping        |
| * ECHO SOLVE, LLC (Charlotte, NC)                  | * Tidwell Septic Tanks (Sumter, SC)   |



**CITY OF COLUMBIA  
FOG PROGRAM  
(FATS, OIL & GREASE)**

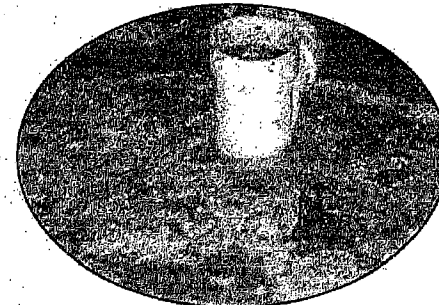

City of Columbia  
Department of Utilities & Engineering  
P.O. Box 147  
Columbia, S.C. 29217  
803-545-3400  
www.columbiasc.net

Fats, Oil and Grease... sound disgusting? Fats, Oil and Grease (commonly referred to as FOG) enter the City of Columbia's sanitary sewer system every day. These items present a big problem in the sewer system. Improper cleanup practices allow food particles, oil and grease, and cleaning products to flow to the sewer system. These types of problems create environmental and public health concerns. When not disposed of properly, FOG form thick layers inside the sewer system and prevent normal flow. Clogged systems result in sewage spills, overflows and odor problems. In addition to this, FOG also attract insects and small animals, causing worse odor problems.

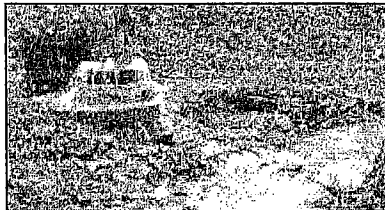

Restaurants produce a significant amount of FOG since grease is used in cooking and other preparation work.

The City of Columbia has a FOG Program to address and prevent FOG from entering the sewer system. Standards and limitations on materials that may be discharged into the City's sanitary sewers are established in the City Code of Ordinances. This helps protect the equipment in the treatment process and is required by the United States Environmental Protection Agency. Appropriate portions of the Code, Chapter 23, Article IV, Section 23-111, can be viewed online at [www.columbiasc.net](http://www.columbiasc.net) or at [www.nunilcode.com](http://www.nunilcode.com). You may also call 645-3400 to request this information by mail.

City inspectors periodically check facilities to make sure they are properly handling grease. They will inspect grease traps and grease interceptors at facilities that are using the City's sewer system. Grease traps and/or grease interceptors must be cleaned out routinely in order to perform properly. Failing to do so may put a facility at risk of violating the City Code, which could lead to enforcement and fines. Facilities are responsible for keeping the grease traps and/or grease interceptors clean and for properly disposing of the fats, oil, grease, sludge, and solids that are removed. Some facilities gather their grease and sell it to companies that use it to make items such as pet food or cosmetics.

Grease traps and grease interceptors work by separating the grease and oil from wastewater. Greasy wastewater entering the trap passes through a vented flow control fitting that regulates the flow of the wastewater. The wastewater then passes over a series of separator baffles or regulating devices within the trap that separate the FOG. The FOG then float to the top of the trap and accumulate until they are manually removed. Solids accumulate at the bottom of the trap and must also be manually removed. Wastewater without grease will continue to flow through the trap into a discharge pipe, and then to the City sewer system if the trap is clean and functioning properly. If the trap is full of grease, grease along with regular wastewater will flow into a discharge pipe, and then to the City sewer system possibly leading to Code violations and fines. Routine maintenance is key to keeping FOG out of the City's sewer system. It will also help reduce stoppages on private

property and in the City's sewage collection system. By doing your part, you can contribute to a cleaner and healthier Columbia.

### Best Management Practices for Grease Removal:

#### Grease Traps:

Grease traps are typically indoor fixtures located under or near a sink. They should be cleaned on a regular basis. Cleaning the trap is a simple procedure that can take little time. Traps can be cleaned by in-house staff or by a licensed grease hauler or recycler. The interval between cleaning depends on the individual establishment. A good rule of thumb is to clean the trap weekly. If the trap is more than 50% full of solids when cleaned weekly, increase the frequency of cleaning. Management should witness or inspect the cleaning to ensure it is done properly.

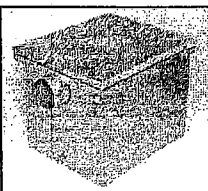

#### When cleaning:

1. Make sure that all flow going to the trap has stopped.
2. Remove the cover of the trap and scoop out any FOG that have collected on top.
3. Bail out the water remaining in the trap to facilitate cleaning.
4. Remove baffles if possible.
5. Scrape the sides, the lid and the baffles to remove as much FOG as possible and deposit it in a grease waste container.
6. Replace the baffle and lid.
7. Record the volume of grease removed on a maintenance log.
8. Keep the maintenance log up to date and readily accessible. This serves as a record of the cleaning frequency and can help the establishment manager optimize cleaning frequency to reduce costs.

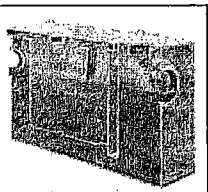

#### Grease interceptors:

A grease interceptor is much larger than a grease trap and is usually located in a vault outside of the establishment. The minimum size is 750 gallons. It too should be cleaned on a regular basis, however, a licensed grease hauler or recycler should perform grease interceptor maintenance. Cleaning the interceptor vaults requires special training and equipment. It is very important that a restaurant representative be present during any cleaning, pumping, or skimming performed by a contractor to ensure that no shortcuts are taken. The minimum services should include:

1. Complete pumping and cleaning of the interceptor and sample box (not just skimming

2. Deodorizing and thorough cleaning of affected areas, as necessary.
3. Disposing or reclaiming of grease and oil at an approved location.
4. Refilling the vault with clean water (not with water already pumped out).

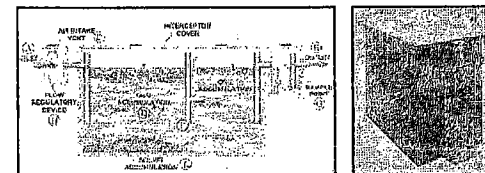

The cleaning frequency depends on the individual establishment. Interceptors require cleaning at least every six months. However, frequency depends on the capacity of the device, the amount of grease in the wastewater, and the degree to which the facility has contributed to blockages in the past. Thus, the frequency can range from every two weeks to every six months.

#### Oil and Water Separators:

Oil and water separators are large capacity, underground cement vaults installed between a drain and the connecting sewer pipe. These vaults are designed with baffles to trap sediments and retain floating oils while allowing the remaining wastewater to be discharged to the wastewater collection system by gravity. The large capacity of the vaults slows down the wastewater, allowing oil to float to the surface and solid material to settle out.

Any business that plans to discharge oily or sediment-laden wastewater to the sewer must install, use and maintain an oil and water separator. Businesses that typically need oil and water separators include:

- Quick lube stations
- Transportation fueling facilities
- Vehicle/heavy equipment repair facilities
- Businesses using steam or pressure washers

Many think that if the separator is still draining, it is working; but like any "filter" an oil and water separator needs occasional cleaning. A separator's efficiency is most affected by solid solids or sludge and by oils. You should inspect the separator at least every six months.

#### When cleaning:

1. Open the inspection plates with a screwdriver and look in each chamber. Make sure the outlet chamber (usually the side closest to the street) has a sampling "T." It should have at least a six-inch extension below the water surface.
2. Take a long sock that will reach the bottom (about 8 feet). Any resistance to push through to the bottom will indicate a sludge buildup. Service the oil and water separator when the buildup is about 8 inches deep in the inlet chamber (typically the one closest to the drain).

**EXHIBIT D**

[DATE]

Re: Violation of the City of Columbia Code of Ordinances Concerning Treatment of Wastewater; [NAME OF RESTAURANT/FACILITY AND LOCATION]

[FSE Owner identified on Registration]  
[BUSINESS NAME]  
[ADDRESS LINE 1]  
[ADDRESS LINE 2]

Dear [FSE Owner]:

The City of Columbia has a FOG (Fats, Oil and Grease) program to address and prevent FOG from entering the sanitary sewer system. Standards and limitations on materials that may be discharged into the City's sanitary sewers are established in the City Code of Ordinances, in conjunction with Utilities and Engineering's Regulations Part 29 and Part 30. The FOG program helps protect the City's wastewater collection and treatment system and is required by the United States Environmental Protection Agency. The Utilities and Engineering's Regulations Part 29 and Part 30 can be viewed in its entirety online at <http://columbia.sc.gov/index.cfm/departments/utilities-engineering/engineering-regulations/>.

On [DATE], City staff inspected the grease trap and/or grease interceptor associated with your Food Service Establishment (FSE) located at [LOCATION]. The inspector observed the following deficiencies that are in violation of the City of Columbia Utilities and Engineering Regulation Part 29:

- Failure to Clean, Maintain, Repair, and/or Replace Grease Trap and/or Grease Interceptor
- Failure to Identify all FSEs Connected to Shared Interceptor
- Excessive FOG Contribution  Failure to Submit FOG Registration
- Sale/Change of Ownership  Change in Operations
- Failure to Produce and/or Maintain Required Records
- Other Noncompliance: \_\_\_\_\_

The implementation of a cleaning and maintenance schedule consisting of routine inspections and grease removal in accordance with Part 29 is essential to ensuring compliance with the applicable ordinance and regulations in the City's FOG program. Another inspection will be made fifteen (15) days after the date of this letter to determine whether the deficiencies denoted above have been corrected. The City's next inspection will include, in part, a review of maintenance records for your grease trap(s) and grease interceptor(s). If upon re-inspection your FSE is not in full compliance or fails to remain in compliance thereafter, enforcement action may be initiated pursuant to the City of Columbia Code of Ordinances, Chapter 23, and Part 29,

including, but not limited to, termination of your facility's water or wastewater service pursuant to Section 23-111 of Chapter 23.

If you have questions concerning the inspection, please call the inspector [NAME] at [NUMBER].

Yours very truly,

Stephen B. Sealey  
Wastewater Compliance Specialist

CC: Ms. Missy Smith Gentry, P.E., Assistant City Manager  
Mr. Joseph D. Jaco, P.E., Director of Utilities and Engineering  
Mr. William H. Davis, P.E., Wastewater Engineer

**EXHIBIT E**

[DATE]

Re: Violation of the City of Columbia Code of Ordinances Concerning Treatment of Wastewater; [NAME OF RESTAURANT/FACILITY AND LOCATION]

[FSE Owner identified on Registration]  
[BUSINESS NAME]  
[ADDRESS LINE 1]  
[ADDRESS LINE 2]

Dear [FSE Owner]:

The City of Columbia has a FOG (Fats, Oil and Grease) program to address and prevent FOG from entering the sanitary sewer system. Standards and limitations on materials that may be discharged into the City's sanitary sewers are established in the City Code of Ordinances, in conjunction with Utilities and Engineering's Regulations Part 29 and Part 30. The FOG program helps protect the City's wastewater collection and treatment system and is required by the United States Environmental Protection Agency. The Utilities and Engineering's Regulations Part 29 and Part 30 can be viewed in their entirety online at <http://columbia.sc.gov/index.cfm/departments/utilities-engineering/engineering-regulations/>.

On [DATE], City staff inspected your Food Services Establishment (FSE) located at [LOCATION] and observed the following deficiencies that are in violation of Utilities and Engineering's Regulations Part 29 and Part 30.

- No Grease Trap/Grease Interceptor
- Irreparable Grease Trap/Interceptor
- Failure to comply with Section 3.2 of Part 29 following Change of Use, Remodeling, Expansion, and/or Modifications to Waste Plumbing System
- Failure to Have/Maintain Plumbing Connections

In order to bring your FSE into compliance with the applicable regulations, you must proceed with the following actions in accordance with the stated schedule of compliance:

- a. Submit a corrective action plan which shall meet the standards and limitations stated in the Ordinance and Parts 29 and 30. Your corrective action plan must be submitted to the Wastewater Compliance Section, 1200 Simon Tree Lane, Columbia, SC 29201 within 15 days of the date of this letter for review and approval.
- b. Upon your receipt of written notification of the City's approval of the corrective action plan, you must construct the improvements. Construction must be completed within 45 days of the date of the City's written approval of the

corrective action plan. You are required to notify the City when you plan to begin construction in order that a pre-construction inspection may be scheduled. You are responsible for providing the City with a minimum of 24 hours advance notice, during the normal work week, prior to the start of construction to allow appropriate time for scheduling.

- c. Full compliance with the Ordinance and Regulations, including correction of the deficiencies denoted above, is required within the compliance schedule stated herein.

If you are unable to comply with the schedule set forth herein, you must request, in writing, an extension of the schedule. This request should be addressed to me and should contain specific reasons and justifications for the request. Only in the most extenuating of circumstances will such requests be granted. If such a request is granted, you will receive written notification of same within [INSERT] days of the date of your submission, which notification will include a new compliance deadline.

The City's next inspection will include, in part, a review of your maintenance records for your grease trap(s) and/or grease interceptor(s). If upon re-inspection your FSE is not in full compliance or fails to remain in compliance thereafter, an enforcement action may be initiated pursuant to the City of Columbia Code of Ordinances, Chapter 23, and Part 29, including, but not limited to, termination of your facility's water or wastewater service pursuant to Section 23-111 of Chapter 23. If you have questions concerning the inspection, please call the inspector [NAME] at [NUMBER].

Yours very truly,

Stephen B. Sealey  
Wastewater Compliance Specialist

CC: Ms. Missy Smith Gentry, P.E., Assistant City Manager  
Mr. Joseph D. Jaco, P.E., Director of Utilities and Engineering  
Mr. William H. Davis, P.E., Wastewater Engineer



**EXHIBIT F**

[DATE]

Re: Violation of the City of Columbia Code of Ordinances Concerning Treatment of Wastewater; [NAME OF RESTAURANT/FACILITY AND LOCATION]

[FSE Owner identified on Registration]  
[BUSINESS NAME]  
[ADDRESS LINE 1]  
[ADDRESS LINE 2]

Dear [FSE Owner]:

A follow-up inspection of the City's sanitary sewer system at the subject location was conducted on [DATE]. Based on this inspection, the excess grease discharge violation described in the letter from the City dated [DATE] appears to have been corrected. The City will take no further enforcement action at this time.

Discharges of fats, oil, and grease into the sanitary sewer system can usually be prevented through regular maintenance of an adequate grease removal system providing maintenance is scheduled at a frequency appropriate to the system loading.

The City will continue to review maintenance records for your [GREASE TRAP OR GREASE INTERCEPTOR] at future inspections. You will need to document maintenance on a continual basis if you are not already doing so.

Your prompt attention in correcting this violation is appreciated. Should you have any questions, please call the inspector at (803) 255-8927.

Yours very truly,

Stephen B. Sealey  
Wastewater Compliance Specialist

CC: Mr. Joseph D. Jaco, P.E., City Engineer  
Mr. William H. Davis, P.E., Wastewater Engineer

**EXHIBIT G**

[DATE]

Re: City Approval of Fats, Oils,  
and Grease Removal System;  
[NAME OF  
RESTAURANT/FACILITY  
AND LOCATION]

[FSE Owner identified on the FOG Registration]  
[BUSINESS NAME]  
[ADDRESS LINE 1]  
[ADDRESS LINE 2]

Dear [FSE Owner]:

The City of Columbia has a FOG (Fats, Oil and Grease) program to address and prevent FOG from entering the sanitary sewer system. Standards and limitations on materials that may be discharged into the City's sanitary sewers are established in the City Code of Ordinances. The FOG program helps protect the wastewater collection and treatment system and is required by the United States Environmental Protection Agency.

On [DATE], City staff inspected a [Grease Trap or Grease Interceptor] at your Food Service Establishment (FSE) at [LOCATION] to confirm that the [Grease Trap or Grease Interceptor] complies with the sizing and design requirements in Regulation Part 30, *Specifications for Grease Traps and Grease Interceptors*. The inspector has conditionally approved your [Grease Trap or Grease Interceptor] based on future satisfactory performance of the system. A proper maintenance schedule of cleaning, pumping, and routine inspections is mandatory. The nature and quantity of future discharges may also make system improvements necessary. The City will review maintenance records for the disposal of FOG at future inspections. This conditional approval is limited to the City's assessment of the compliance of your FSE's [Grease Trap or Grease Interceptor] with the sizing and design requirements in Regulation Part 30, *Specifications for Grease Traps and Grease Interceptors*, and does not address or concern other matters related to the sufficiency of the installation, plumbing connections, performance, operation or maintenance of your FSE's [Grease Trap or Grease Interceptor].



Periodic inspections will be made to determine if proper maintenance has been conducted on your approved FOG removal system. If you have questions concerning the inspection, please call the inspector at (803) 255-8927.

Yours very truly,

Stephen B. Sealey  
Wastewater Compliance Specialist

CC: Mr. Joseph D. Jaco, P.E., City Engineer  
Mr. William H. Davis, P.E., Wastewater Engineer

**EXHIBIT H**

[DATE]

Re: Re-Inspection Violation of  
the City of Columbia Code of  
Ordinances Concerning  
Treatment of Wastewater;  
[NAME OF  
RESTAURANT/FACILITY  
AND LOCATION]

**BY HAND DELIVERY**  
**WITH ACKNOWLEDGMENT OF RECEIPT**

[FSE Owner identified on FOG Registration]  
[BUSINESS NAME]  
[ADDRESS LINE 1]  
[ADDRESS LINE 2]

Dear [FSE Owner]:

The City of Columbia notified you by letter dated [DATE], that your Food Service Establishment (FSE) was in violation of the City of Columbia Code of Ordinances. On [DATE], City staff re-inspected your FSE located at [LOCATION]. The inspector determined that proper actions had not been conducted to correct violations and/or that your FSE was in violation of the City of Columbia Code of Ordinances.

If your FSE is not in full compliance with the Code of Ordinances within seven calendar days of your receipt of this letter, this matter will be referred to the City Attorney to initiate an enforcement action pursuant to City of Columbia Code of Ordinances, Chapter 23, including, but not limited to, termination of your FSE's water and/or wastewater service. In addition, the City reserves the right to pursue any other remedies provided by law for the subject violation(s).

Should you have any questions, please call me at (803) 733-8566.

Yours very truly,

Stephen B. Sealey  
Wastewater Compliance Specialist

cc: Ms. Teresa B. Wilson, City Manager  
Mr. Kenneth E. Gaines, City Attorney  
Mr. Joseph D. Jaco, P.E., City Engineer  
Mr. William H. Davis, P.E., Wastewater Engineer

## **Appendix H**

## Appendix H

### List of Pump Stations with Capacity Ratings Greater than 1000 GPM

| Station ID # | Name           | Reliable Capacity (GPM)* | Number of Pumps** | TDH (ft) |
|--------------|----------------|--------------------------|-------------------|----------|
| 110          | West Columbia  | 16,666                   | 4                 | 85       |
| 295          | North Columbia | 14,580                   | 6                 | 102      |
| 335          | Broad River    | 6,300                    | 4                 | 217      |
| 065          | Mill Creek     | 9,000                    | 4                 | 110      |
| 195          | Saluda River   | 10,420                   | 4                 | 129      |

\* Reliable capacity with largest pump out of service

\*\* Includes redundant pump

## **Revised Appendix I**

**REVISED APPENDIX I**  
**SUPPLEMENTAL ENVIRONMENTAL PROJECT**

Pursuant to the terms set forth in Section VIII of this Consent Decree, Columbia will perform a Supplemental Environmental Project (SEP), implementing stream cleanup, flooding, and/or water quality improvement projects in the following three areas (designated as Area 1, Area 2, and Area 3) as described below. Columbia shall spend a total of at least \$1,000,000 to implement this SEP. Columbia, in its sole discretion, may contract with third parties or utilize its own employees and equipment to perform any or all of this SEP. Columbia will be given credit against the total funding obligation for work performed utilizing its own employees or equipment, provided, however, that the work performed is not that which would have otherwise been performed by Columbia's employees. Any such credit for work performed utilizing Columbia's own employee or equipment must be supported by time and expense records.

In order to perform this SEP, Columbia must obtain the consent of private property owners and/or lessees to access certain areas designated for the work described herein. Columbia will make a reasonable effort to obtain the required consent for access, but is under no obligation to exercise its power of eminent domain in circumstances in which consent is not given voluntarily.

Columbia shall complete all work on Areas 1, 2 and 3 within five (5) years of the Effective Date of this Consent Decree; provided, however, that the deadline for any proposed work which requires an individual Clean Water Act Section 404 permit from the U.S. Army Corps of Engineers ("Corps") shall be tolled for the period of time from the submittal of the application for such permit to the Corps until the issuance of the permit to Columbia by the Corps. Columbia shall complete the water quality monitoring component to evaluate the effectiveness of the SEP within six (6) years of the Effective Date of this Consent Decree.

**Area 1 – Stream Cleanup, Flooding, and/or Water Quality Improvement of the Upper Congaree River Watershed Along the Lower and Middle Reach of Rocky Branch**

Purpose

Columbia has identified Rocky Branch as a high-priority water body within the Upper Congaree River Watershed ("UCRW") that is in need of long-term efforts to improve its water quality, minimize flooding, and identify areas in need of restoration and stabilization. The lower and middle portions of Rocky Branch, starting at the railroad trestle across Blossom Street and ending at the Congaree River, are especially in need of attention. In a study conducted by PB America's Inc. on behalf of the City of Columbia, this area was identified as a significant contributor to upstream flooding (October 2007). This section of Rocky Branch is generally identified as Item 1 on the attached map (hereinafter referred to as "Rocky Branch") and flows through an environmental justice community. High volumes and velocities of stream flow have potentially contributed to stream bank degradation along this section of the watershed. Furthermore, reducing flooding in this region decreases the likelihood that floodwaters will enter the public sewer system through manholes, cleanouts, and faulty or improper connections and

joints, which will benefit the environment by reducing the likelihood and the volume of related SSOs.

### Scope

Columbia will develop and implement, in conjunction with the Rocky Branch Watershed Alliance (“RBWA”), a multi-year, phased project designed to facilitate long-term efforts to improve the water quality of Rocky Branch. During the initial phase of this project (“Phase I of the Rocky Branch Project”), Columbia will engage a consultant, in consultation with RBWA, to develop an integrated Watershed Management Plan consistent with the planning protocols of the Center for Watershed Protection. The consultant will utilize prior assessments conducted by the City and RBWA and conduct new assessments as required to develop a comprehensive plan that prioritizes actions and capital improvements required to meet the long-term goals for Rocky Branch, including those beyond the scope of Phase II of the Rocky Branch Project.

The second phase (“Phase II of the Rocky Branch Project”) will implement projects identified in the Watershed Management Plan developed during Phase I. Projects will be implemented on a prioritized scale to improve water quality and reduce flood risk as determined by the City of Columbia in consultation with RBWA. This phase also includes implementing engineering techniques designed to improve water quality, minimize flooding, and restore and stabilize stream banks of Rocky Branch, such as stream and riparian buffer restoration, re-vegetation and low impact design standards. Additionally, Columbia shall maintain those selected engineering techniques until EPA determines that Columbia has satisfactorily completed this SEP pursuant to Paragraph 33 of the Consent Decree. Any remaining funds will be used for a one-time stream clean up project, consisting of removal of debris, such as trash, furniture, household appliances, tires, and construction debris, from the banks and contiguous stream beds of Area 1 accessible from Rocky Branch and within the municipal limits of the City. Columbia will secure necessary federal, state, and local permits for the project and will dispose of and/or recycle all removed debris consistent with applicable federal, state, and local requirements.

Within twenty-four (24) months of the Effective Date of this Consent Decree, Columbia will complete Phase I of the Rocky Branch Project.

Within three (3) years of the Effective Date of this Consent Decree, Columbia will submit to EPA the preliminary report on the condition of Rocky Branch and a plan for Phase II of the Rocky Branch Project, including Columbia’s selected techniques designed to improve water quality, minimize flooding, and restore and stabilize stream banks of Rocky Branch.

As indicated above, all work in Area 1 shall be completed within five (5) years of the Effective Date of this Consent Decree.



## **Area 2 – Stream Cleanup and Water Quality Improvement of Smith Branch**

### Purpose

In conjunction with Congaree Riverkeeper, Columbia has identified Smith Branch as a high-priority water body in need of a long-term effort to improve its water quality. The Broad River watershed contains the northern area of the City of Columbia. It includes the I-26, I-20, and I-77 corridors, along with the U.S. Hwy. 321, U.S. Hwy. 21, and U.S. Hwy. 176. Located within the City of Columbia corporate limits, Smith Branch is the most urbanized tributary of the Broad River. Approximately 81% of this watershed is urban, 15% is forest, and 2% is farmland. Its main stem headwater rises on property owned by the S.C. Department of Mental Health, and crosses Interstate 277 and North Main Street. Once the stream crosses Interstate 277, a tributary rising near the neighborhoods of Bethel-Bishop-Chappell Community, Booker Washington Heights Neighborhood, and the Colony Community flows southward to discharge into Smith Branch. Smith Branch then crosses Earlewood Park Neighborhood, Hyatt Park Neighborhood, and Colonial, Colonial West and Colonial Heights Neighborhoods before emptying into the Broad River. This section of Smith Branch from the Earlewood Park Neighborhood to the Broad River is generally described as Item 2 on the attached map (hereinafter referred to as “Smith Branch”) and flows through an environmental justice community.

Smith Branch is impaired both for recreational use and for aquatic life uses. In water samples tested by DHEC from 1998 through 2002, 89% of samples taken from Smith Branch exceeded the 400 cfu/100 ml water quality standard for fecal coliform. High fecal coliform concentrations in Smith Branch is likely caused by stormwater runoff, pet excrement, leaking sewer pipes, and failing septic tanks. In 2005, DHEC developed a Total Maximum Daily Load (“TMDL”) for fecal coliform in the Broad River, Crane Creek and Smith Branch. The TMDL for Smith Branch specifies a reduction in the load of fecal coliform bacteria into Smith Branch of 99% in order for the creek to meet the recreational use standard. As of 2010, Smith Branch still does not meet state water quality criteria to support recreational uses. Similarly, aquatic life in Smith Branch is impaired as demonstrated by the stream’s loss of benthic habitat. According to DHEC, the likely cause of impaired aquatic life on Smith Branch is pollution entering the stream through stormwater runoff. Poor benthic habitat may also be associated with the canalization of the stream with very little opportunity for riffles and pools to form. There is also much evidence of littering in the stream. Smith Branch is one of the first two streams in South Carolina to be the subject of a TMDL to address impaired aquatic life.

### Scope

During the initial phase of this project (“Phase I of the Smith Branch Project”), Columbia will engage a design professional in consultation with Congaree Riverkeeper to develop a Smith Branch Comprehensive Watershed Management Plan consistent with the planning protocols of the Center for Watershed Protection.

During the second phase of this project (“Phase II of Smith Branch Project”), Columbia will conduct a one-time stream cleanup project in an effort to improve the overall quality and sustainability of Smith Branch. The stream cleanup project shall consist of removal of debris,

such as trash, furniture, household appliances, tires, and construction debris, from the banks and contiguous stream beds of Area 2 accessible from Smith Branch and within the municipal limits of the City. Columbia will secure necessary federal, state, and local permits for the project and will dispose of and/or recycle all removed debris consistent with applicable federal, state, and local requirements. This phase may also include additional projects identified in the Smith Branch Watershed Management Plan developed during Phase I. For those Phase II projects which include implementing engineering techniques, Columbia shall maintain those engineering techniques until EPA determines that Columbia has satisfactorily completed this SEP pursuant to Paragraph 33 of the Consent Decree.

Within twenty-four (24) months of the Effective Date of this Consent Decree, Columbia will complete Phase I of the Smith Branch Project.

Within three (3) years of the Effective Date of this Consent Decree, Columbia will submit to EPA the preliminary report on the condition of Smith Branch and a plan for Phase II of the Smith Branch Project, including Columbia's selected techniques designed to improve water quality, minimize flooding, and restore and stabilize stream banks on Smith Branch.

As indicated above, all work in Area 2 shall be completed within five (5) years of the Effective Date of this Consent Decree.

### **Area 3 – Stream Cleanup and Water Quality Improvements of Gills Creek**

#### Purpose

Columbia has also identified Gills Creek as a high-priority water body in need of long-term efforts to improve its water quality. The Gills Creek Watershed contains over 70 miles of streams and encompasses multiple jurisdictions. Within the City of Columbia corporate limits, Gills Creek is primarily in the southeastern part of the city from the municipal border with Forest Acres down to where Gills Creek empties into the Congaree River. There is a high potential for continued growth in this urban watershed, which contains a portion of the City of Columbia. Although primarily residential, there are a substantial number of commercial and industrial areas. Almost the entire watershed, which runs through the City of Columbia, has water and sewer readily available. Growth is also projected along the newly connected I-77 beltway around the city (SCDHEC, Gills Creek Watershed Evaluation).

Besides the main stem of Gills Creek, there are many additional tributaries and associated wetlands that feed into the system; Penn Branch, Wildcat Creek and Kilbourne Creek are just a few. All waters feeding into Gills Creek are classified as FW (freshwater). DHEC issued TMDLs for two stations in Gills Creek: C-017 for Dissolved Oxygen, Fecal Coliform and C-001 for Fecal Coliform.

#### Scope

The Gills Creek Watershed Management Plan dated May 2009 identifies watershed management projects to improve the water quality of Gills Creek. In conjunction with the Gills Creek

Watershed Association, the City has identified the certain projects to be conducted on the section of Gills Creek which is generally described as Item 3 on the attached map (hereinafter referred to as “Gills Creek”) and flows through an environmental justice community. During the initial phase of this project (“Phase I of the Gills Creek Project”), the City will implement the following projects in the Gills Creek Watershed:

- 1) Install a pocket wetland or other similar best management practice (BMP) at the end of Pelham Drive near where it meets Gills Creek Parkway;
- 2) Install a pocket wetland or other similar BMP at the end of Hampton Leas Lane where the road dead ends into the Gills Creek floodplain;
- 3) Install a pocket wetland or other similar BMP at the end of Tall Pines Circle where the road dead ends in the Gills Creek floodplain;
- 4) Install an erosion control BMP and outlet protection at the two major discharges entering the Gills Creek floodplain under Gills Creek Parkway;
- 5) Install a pocket wetland or other similar BMP at the end of Edmond Drive where the stormwater network drains to the Gills Creek floodplain (tax map number R13709-03-11); and
- 6) Install a pocket wetland or other similar BMP at the end of Hampton Trace Lane where the stormwater network drains to the Gills Creek floodplain (tax map number R13709-03-05).

Columbia shall maintain these BMPs until EPA determines that Columbia has satisfactorily completed this SEP pursuant to Paragraph 33 of the Consent Decree. During the second phase of this project (“Phase II of Gills Creek Project”), Columbia will conduct a one-time stream cleanup project on select portions of Gills Creek as prioritized by the City in consultation with the Gills Creek Watershed Association. The stream cleanup project shall consist of removal of debris, such as trash, furniture, household appliances, tires, and construction debris, from the banks and contiguous stream beds of Area 3 accessible from Gills Creek. Columbia will secure necessary federal, state, and local permits for Phase I and Phase II of the project and will dispose of and/or recycle all debris removed during the project consistent with applicable federal, state, and local requirements.

Within twenty-four (24) months of the Effective Date of this Consent Decree, Columbia will complete Phase I of the Gills Creek Project.

Within three (3) years of the Effective Date of this Consent Decree, Columbia will submit to EPA the preliminary report on the condition of Gills Creek and a plan for Phase II of the Gills Creek Project, including Columbia’s selected techniques designed to improve water quality of the section of Gills Creek.

As indicated above, all work in Area 3 shall be completed within five (5) years of the Effective Date of this Consent Decree.

## Water Quality Monitoring Component

In addition to the work described above, Columbia will conduct the water quality monitoring described below to assist in evaluation of the environmental benefits of the SEP in improving water quality in Smith Branch and Gills Creek.

### I. Monitoring

The City of Columbia will implement a program for ambient monitoring of dissolved oxygen (DO), total suspended solids (TSS), temperature (temp) and *E. coli*<sup>1</sup> at the monitoring sites listed below. Columbia will conduct the monitoring in accordance with an approved South Carolina Department of Health and Environmental Control (DHEC) quality assurance project plan (QAPP). Columbia will have the TSS and *E. coli* data analyzed at a DHEC certified lab.<sup>2</sup> By using established monitoring sites, water quality data collected by Columbia will be available for comparison to historic water quality data taken by DHEC for assessment purposes. Within sixty (60) days of entry of the Consent Decree, Columbia will submit a QAPP to DHEC for review and approval. Columbia will begin monitoring within thirty (30) days of DHEC's approval of the QAPP. As indicated below, Columbia will monitor quarterly for the first 3 years under the Consent Decree and monthly (or every other month at Site C-17) from years 4 through 6 under the Consent Decree.

### II. Water Quality Stations (see attached map):

| Site  | Description                      | Impairment           | TMDL | Monitoring Parameters               | Frequency  |
|-------|----------------------------------|----------------------|------|-------------------------------------|--|
| C-001 | Gills Creek at Garners Ferry Rd. | Fecal Coliform       | Yes  | DO<br><i>E. coli</i><br>Temp<br>TSS | Quarterly during years 1-3, and monthly during year 4-6                              |
| B-280 | Smith Branch at N. Main Street   | Fecal Coliform       | Yes  | DO<br><i>E. coli</i><br>Temp<br>TSS | Quarterly during years 1-3, and monthly years 4-6                                    |
| C-017 | Gills Creek at Bluff Road        | Fecal Coliform<br>DO | Yes  | DO<br><i>E. coli</i><br>Temp<br>TSS | Quarterly during years 1-3, and every other month (between DHEC samplings) years 4-6 |

Columbia shall provide EPA and DHEC the results of its water quality monitoring in the Quarterly Reports required under the Consent Decree.

<sup>1</sup> *E. coli* standard replaces the existing fecal coliform standard.

<sup>2</sup> The temp and DO parameters measured in the field with a probe are not subject to the certified laboratory requirement.



# CITY OF COLUMBIA - SEP ITEMS

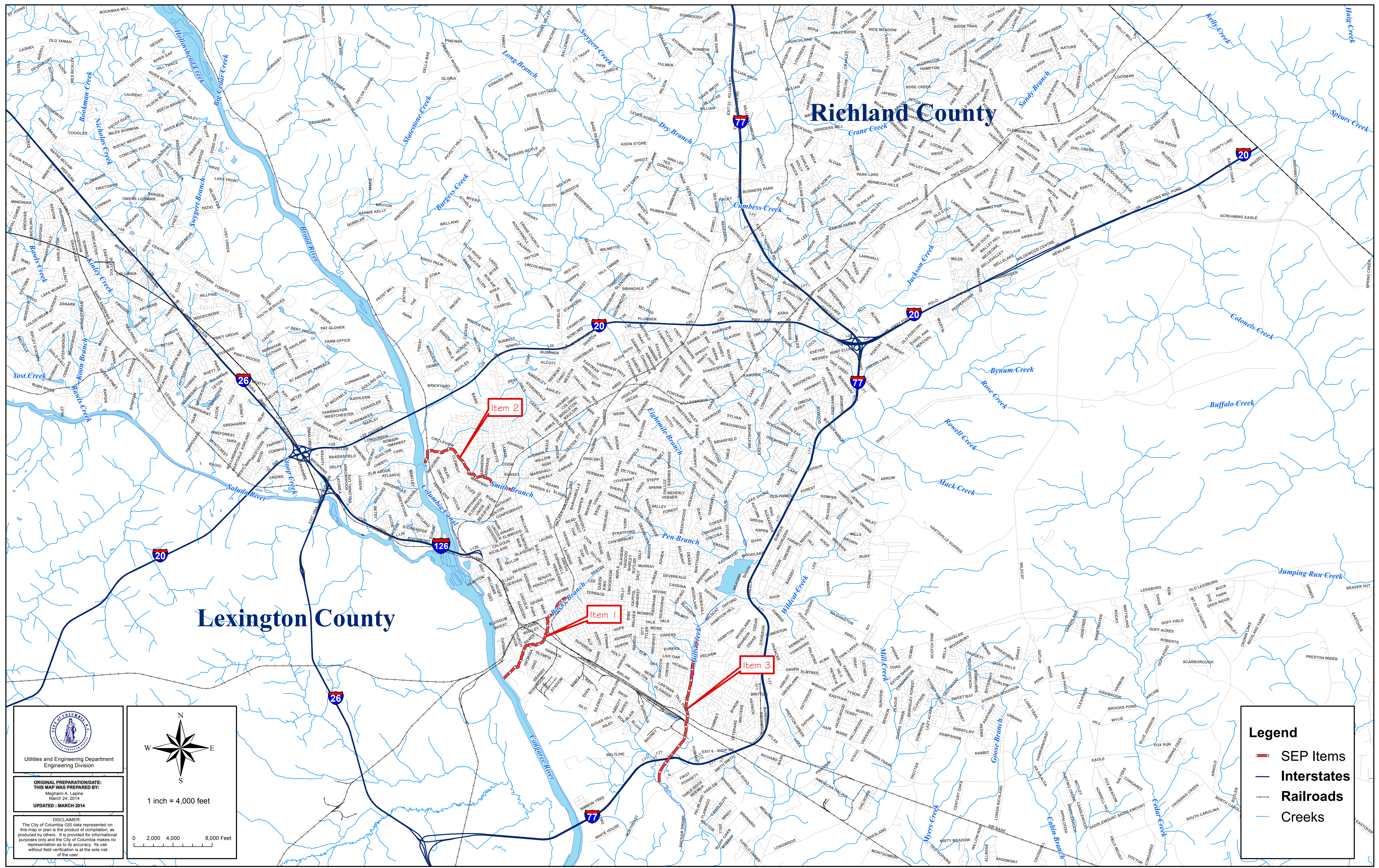

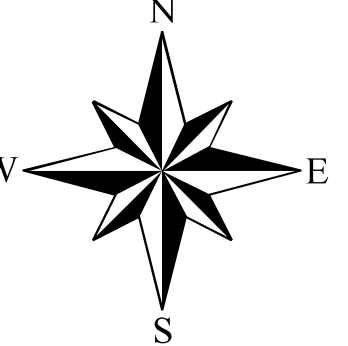
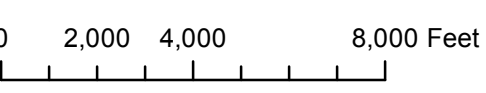

  
 Utilities and Engineering Department  
 Engineering Division

  
 1 inch = 4,000 feet  

**ORIGINAL PREPARATION/DATE:**  
 THIS MAP WAS PREPARED BY:  
 Meghan A. Laine  
 March 24, 2014  
**UPDATED: MARCH 2014**

**DISCLAIMER:**  
 The City of Columbia GIS data represented on this map or plan is the product of compilation, as produced by others. It is provided for informational purposes only and the City of Columbia makes no representation as to its accuracy. Its use without field verification is at the sole risk of the user.

**Legend**

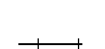
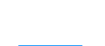
-  SEP Items
-  Interstates
-  Railroads
-  Creeks



# Columbia Water Quality Monitoring

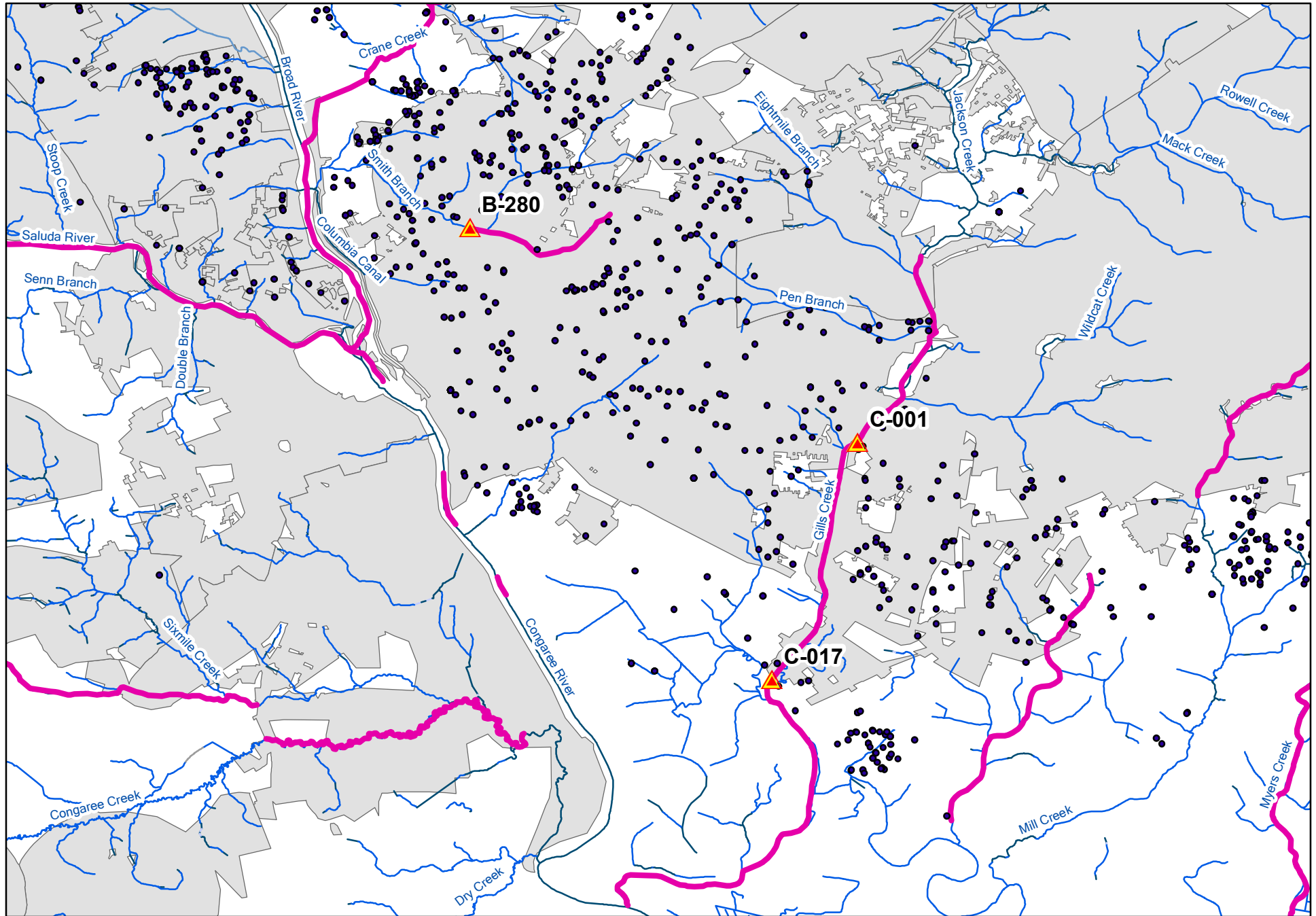

## Legend

-  Columbia SEP Monitoring Sites
-  SSOs
-  303(d) Waters-2010
-  Populated Places